

TECHNICAL MANUAL

**OPERATOR'S, UNIT, AND
DIRECT SUPPORT
MAINTENANCE MANUAL**

**800K GALLON WATER STORAGE
AND
DISTRIBUTION SYSTEM
MODEL WSDS810
NSN: 4610-01-360-1581
AND
MODEL 800KWSDS
NSN: 4610-01-382-3547**

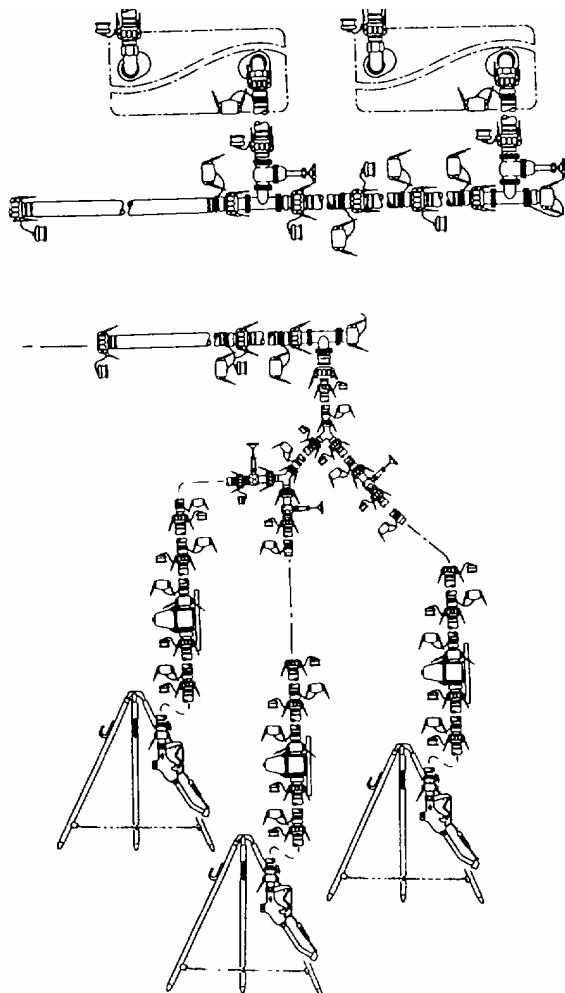

HOW TO USE THIS MANUAL	iii
EQUIPMENT DESCRIPTION AND DATA	1-3
OPERATION UNDER USUAL CONDITIONS	2-27
OPERATOR TROUBLESHOOTING PROCEDURES	3-1
UNIT MAINTENANCE PROCEDURES	4-1
DIRECT SUPPORT MAINTENANCE PROCEDURES	5-1
MAINTENANCE ALLOCATION CHART	B-1
COMPONENTS OF END ITEM AND BASIC ISSUE ITEMS LIST	C-1
EXPENDABLE/DURABLE SUPPLIES AND MATERIALS LIST	E-1
ALPHABETICAL INDEX	Index-1

DISTRIBUTION STATEMENT A: Approved for public release; distribution is unlimited

WARNINGS

HIGH PRESSURE

Do not open hose couplings when water system is under pressure. Hose end can whip, causing injury to personnel and damage to equipment.

CONTAMINATION HAZARD

To prevent contamination of drinking water, make sure all couplings are capped and plugged when components are not connected or not in use.

Keep dirt, mud, sand and debris from entering open couplings during assembly and disassembly.

Have water tested by medical personnel before dispensing to users.

Do not use petroleum based lubricants in the water system.

HEAVY EQUIPMENT HAZARD

Lifting or moving heavy equipment incorrectly can cause serious injury. Do not try to lift or move more than 50 pounds by yourself. Get an assistant. Bend legs while lifting. Don't support heavy weight with your back.

Always use assistants during lifting operations. Use guide ropes to move hanging assemblies.

A lack of attention or being in an improper position during lifting operations can result in serious injury or death. Pay close attention to movements of assemblies being lifted. Do not stand under lifted assembly or in a position where you could be pinned against another object. Watch your footing.

Hoist used to lift water tanks from water tank chests must have minimum lifting capacity of 750 pounds.

FIRE HAZARD

To prevent injury to personnel and damage to equipment, do not over-fill fuel tanks on 125 and 350 gpm pumps. Make sure a fire extinguisher is nearby when refueling or operating the water pumps. Refer to the applicable TM for correct filling procedures.

FIRST AID

For artificial respiration, refer to FM 4-25.11.

a/(b blank)

CHANGE
NO. 3

HEADQUARTERS
DEPARTMENT OF THE ARMY
WASHINGTON, D.C., 2 February 2007

OPERATOR'S, UNIT AND DIRECT SUPPORT
MAINTENANCE MANUAL
FOR
800K WATER STORAGE AND DISTRIBUTION SYSTEM
MODEL WSDS810
NSN: 4610-01-360-1581
AND
MODEL 800KWDS
NSN: 4610-01-382-3547

TM 10-4610-243-13, 4 December 1992, is changed as follows:

DISTRIBUTION STATEMENT A: Approved for public release; distribution is unlimited.

1. Retain this sheet in front of manual for reference purposes.
2. New or changed text material is indicated by a vertical bar in outer margins of the page.
3. Changes to illustration figure titles are indicated by a vertical bar adjacent to the title. An illustration change is indicated by a miniature pointing hand.
4. Front Cover Title has Changed.
5. Remove and insert pages as indicated below.

Remove pages

I and ii
none
B-1 thru B-8
none
2028-2
2028-2
Front Cover

Insert pages

i and ii
A and B/blank
B-1 thru B-10
Electronic 2028
2028
2028
Front Cover

TM 10-4610-243-13

By Order of the Secretary of the Army:

PETER J. SCHOOMAKER
General, United States Army
Chief of Staff

Official:

A handwritten signature in cursive script that reads "Joyce E. Morrow".

JOYCE E. MORROW
Administrative Assistant to the
Secretary of the Army

0701710

DISTRIBUTION: To be distributed in accordance with the Initial Distribution Number (IDN) 256018, requirements for TM 10-4610-243-13.

CHANGE

NO.2

HEADQUARTERS
DEPARTMENT OF THE ARMY
WASHINGTON, D.C., 15 JULY 1995

Operator's Unit and Direct Support
Maintenance Manual

800K WATER STORAGE AND DISTRIBUTION SYSTEM
MODEL WSDS810
NSN: 4610-01-360-1581 AND
MODEL 800KWSDS
NSN: 4610-01-382-3547

DISTRIBUTION STATEMENT A: Approved for public release; distribution is unlimited

TM 10-4610-243-13, 4 December 1992, is changed as follows:

1. Remove and insert pages as indicated below. New or changed text material is indicated by a vertical bar in the margin. An illustration change is indicated by a miniature pointing hand.

Remove pages
1-9 and 1-10

Insert pages
1-9 and 1-10

2. Retain this sheet in front of manual for reference purposes.

By Order of the Secretary of the Army:

Official:

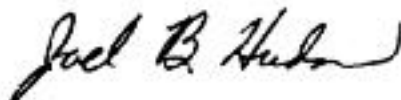

*Acting Administrative Assistant to the
Secretary of the Army*

00600

DENNIS J. REIMER
*General, United States Army
Chief of Staff*

DISTRIBUTION:

To be distributed in accordance with DA Form 12-25-E, block no. 6018, requirements for TM 10-4610-243-13.

CHANGE

NO. 1

HEADQUARTERS
DEPARTMENT OF THE ARMY
WASHINGTON, D.C., 29 APRIL 1994

Operator's, Unit and Direct Support
Maintenance Manual
for
800K WATER STORAGE AND DISTRIBUTION SYSTEM
MODEL WSDS810
NSN: 4610-01-360-1581 AND
MODEL 800KWSDS
NSN: 4610-01-382-3547

DISTRIBUTION STATEMENT A: Approved for public release; distribution is unlimited.

TM 10-4610-243-13, 4 December 1992, is changed as follows:

1. Title is changed as indicated above.
2. Remove and insert pages as indicated below. New or changed text material is indicated by a vertical bar in the margin. An illustration change is indicated by a miniature pointing hand.

Remove pages

i and ii
1-1 and 1-2
1-7 and 1-8
2-1 and 2-2
2-13 and 2-14
2-21 and 2-22
2-59 through 2-62

2-63 through 2-66
2-75 through 2-78
4-1 and 4-2
4-57 and 4-58
4-67 and 4-68

4-91 and 4-92

B-5 and B-6
B-9/(B-10 blank)
C-1 through C-14
I-1 and I-2
Index-I through Index-4

Insert pages

i and ii
1-1 and 1-2
1-7 and 1-8
2-1 and 2-2
2-13 and 2-14
2-21 and 2-22
2-59 through 2-62
2-62.1/(2-62.2 blank)
2-63 through 2-66
2-75 through 2-78
4-1 and 4-2
4-57 and 4-58
4-67 and 4-68
4-68.1 through 4-68.5/(4-68.6 blank)
4-91 and 4-92
4-92.1 through 4-92.3/(4-92.4 blank)
B-5 and B-6
B-9/(B-10 blank)
C-1 through C-14
I-1 and I-2
Index-I through Index-4

3. Retain this sheet in front of manual for reference purposes.

By Order of the Secretary of the Army:

Official:

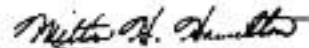

MILTON H. HAMILTON
*Administrative Assistant to the
Secretary of the Army*
06699

GORDON R. SULLIVAN
*General, United States Army
Chief of Staff*

DISTRIBUTION:

To be distributed in accordance with DA Form 12-25-E, block no. 6018, requirements for TM 10-4610-243-13.

INSERT LATEST CHANGED PAGES. DESTROY SUPERSEDED DATA.

LIST OF EFFECTIVE PAGES

NOTE: New or changed text material is indicated by a vertical bar in the outer margins of the page.
 Changes to illustration figure titles are indicated by a vertical bar adjacent to the title.
 Illustration changes are indicated by a miniature pointing hand.

Date of issue for the original manual and changed pages are:

Original 04 December 1992
 Change 1 29 April 1994
 Change 2 15 July 1995
 Change 3 2 February 2007

Page No.	*Change No.	Page No.	*Change No.
a and b	0	4-93 thru 4-130	0
i and ii	3	5-1/(5-2 blank)	0
ii thru iv	0	A-1/(A-2 blank)	0
1-1 and 1-2	1	B-1 thru B-10	3
1-3 thru 1-5/(1-6 blank)	0	C-1 thru C-14	1
1-7 and 1-8	1	D-1/(D-2 blank)	0
1-9 and 1-10	2	E-1 and E-2	0
1-11 and 1-12	0	F-1/(F-1 blank)	0
2-1 and 2-2	1	G-1/(G-2 blank)	0
2-3 thru 2-12	0	H-2 and H-2	0
2-13 and 2-14	1	I-1 and I-2	1
2-15 thru 2-20	0	Index-1 thru Index-4	1
2-21 and 2-22	1		
2-23 thru 2-58	0		
2-59 thru 2-66	1		
2-67 thru 2-74	0		
2-75 thru 2-78	1		
2-79 thru 2-97/(2-98 blank)	0		
3-1 thru 3-29/(3-30 blank)	0		
4-1 and 4-2	1		
4-3 thru 4-56	0		
4-57 and 4-58	1		
4-59 thru 4-66	0		
4-67 and 4-68.5/(4-68.6 blank)	1		
4-69 thru 4-90	0		
4-91 thru 4-92.3/(4-92.4 blank)	1		

TECHNICAL MANUAL

NO: 10-4610-243-13

HEADQUARTERS
DEPARTMENT OF THE ARMY
Washington, D.C., 4 December 1992

**OPERATOR'S, UNIT AND
DIRECT SUPPORT MAINTENANCE MANUAL
for
800K WATER STORAGE AND DISTRIBUTION SYSTEM**

**MODEL WSDS810
NSN: 4610-01-360-1581
AND
MODEL 800KWSDS
NSN: 4610-01-382-3547**

REPORTING ERRORS AND RECOMMENDING IMPROVEMENTS

You can help improve this publication. If you find any mistakes or if you know of a way to improve the procedures, please let us know. Submit your DA Form 2028 (Recommended Changes to Publications and Blank Forms), through the Internet, on the Army Electronic Product Support (AEPS) website. The Internet address is <https://aeeps.ria.army.mil>. The DA Form 2028 is located under the Public Applications section in the AEPS Public Home Page. Fill out the form and click on SUBMIT. Using this form on the AEPS will enable us to respond quicker to your comments and better manage the DA Form 2028 program. You may also mail, fax, or e-mail your letter or DA Form 2028 directly to: AMSTA-LC-LPIT / TECH PUBS, TACOM-RI, 1 Rock Island Arsenal, Rock Island, IL 61299-7630. The e-mail address is ROCK-TACOM-TECH-PUBS@conus.army.mil. The fax number is DSN 793-0726 or Commercial (309) 782-0726.

Distribution Statement A: Approved for public release; distribution is unlimited.

TABLE OF CONTENTS

	PAGE
HOW TO USE THIS MANUAL	iii
CHAPTER 1. INTRODUCTION	
Section I. General Information.....	1-1
Section II. Equipment Description and Data.....	1-3
Section III. Principles of Operation.....	1-10
CHAPTER 2. OPERATING INSTRUCTIONS	
Section I. Description and Use of Operator's Controls and Indicators.....	2-1
Section II. Operator's Preventive Maintenance Checks and Services (PMCS).....	2-7
Section III. Operation Under Usual Conditions.....	2-27
Section IV. Operation Under Unusual Conditions.....	2-93
CHAPTER 3. OPERATOR MAINTENANCE INSTRUCTIONS	
Section I. Lubrication Instructions.....	3-1
Section II. Operator Troubleshooting.....	3-1
Section III. Operator Maintenance Procedures.....	3-26
CHAPTER 4. UNIT MAINTENANCE INSTRUCTIONS	
Section I. Repair parts, Special Tools, Test, Measurement and Diagnostic Equipment (TMDE) and Support Equipment.....	4-2
Section II. Service Upon Receipt.....	4-2
Section III. Unit Troubleshooting Procedures.....	4-6
Section IV. Unit Maintenance Procedures.....	4-27
Section V. Preparation for Storage or Shipment.....	4-130

TABLE OF CONTENTS – cont

	PAGE
CHAPTER 5. DIRECT SUPPORT MAINTENANCE	
Direct Support Maintenance Procedures	5-1
APPENDICES	
Appendix A. References	A-1
Appendix B. Maintenance Allocation Chart	B-1
Appendix C. Components of End Item and Basic Issue Items List.....	C-1
Appendix D. Additional Authorization List.....	D-1
Appendix E. Expendable and Durable Items List	E-1
Appendix F. Lubricating Instructions	F-1
Appendix G. Illustrated List of Manufactured Items	G-1
Appendix H. Torque Limits.....	H-1
Appendix I. Mandatory Replacement Parts.....	I-1
Alphabetical Index	Index-1

HOW TO USE THIS MANUAL

Be sure to read all Warnings before using your equipment.

This manual contains operating and maintenance instructions for operation and maintenance of the 800K Water Storage and Distribution System.

- Chapter 1 - Introduces you to the equipment and gives you information such as weight, height, length, generally used abbreviations and information on how the unit works. The chapter is preceded by a full page illustration of the equipment.
- Chapter 2 - Provides information necessary to identify and use the equipment's operating controls. Operating instructions in this chapter tell you how to use the equipment in both usual and unusual weather conditions. In addition, preventive maintenance instructions provide information needed to inspect and service the 800K Water Storage and Distribution System.
- Chapter 3 - Provides operator troubleshooting procedures for identifying equipment malfunctions and maintenance instructions for performing operator maintenance tasks.
- Chapter 4 - Provides unit maintenance personnel with troubleshooting procedures for identifying equipment malfunctions and maintenance instructions for repairing defective equipment.
- Chapter 5 - Provides direct support maintenance personnel with maintenance instructions for performing repairs on equipment as authorized by the maintenance allocation chart.
- Appendix A - Provides a list of frequently used forms and publications referenced or used in this manual.
- Appendix B - The Maintenance allocation chart identifies repairable components and the maintenance level authorized to perform the repairs.
- Appendix C - Lists components that are not mounted on the equipment, but are required to make the unit functional. All components in the Components of End Item and Basic Issue Items Lists are illustrated for easy identification.
- Appendix D - Lists additional equipment authorized for your unit for use with the 800K system, but are not supplied as part of system. This equipment list may include fire extinguishers, buckets, protective clothing etc.
- Appendix E - Provides you with information about expendable supplies such as sealants, lubricants, chemicals etc. that are used when operating or maintaining the equipment.
- Appendix F - Contains lubrication instructions that are required to keep the equipment in good working condition.
- Appendix G - Provides a list of items and instructions on how to make certain tools and devices required to perform some of the maintenance tasks contained in this manual.
- Appendix H - Lists parts that must be replaced when performing maintenance on components of the water system. This list includes such things as gaskets, lockwashers and seals.

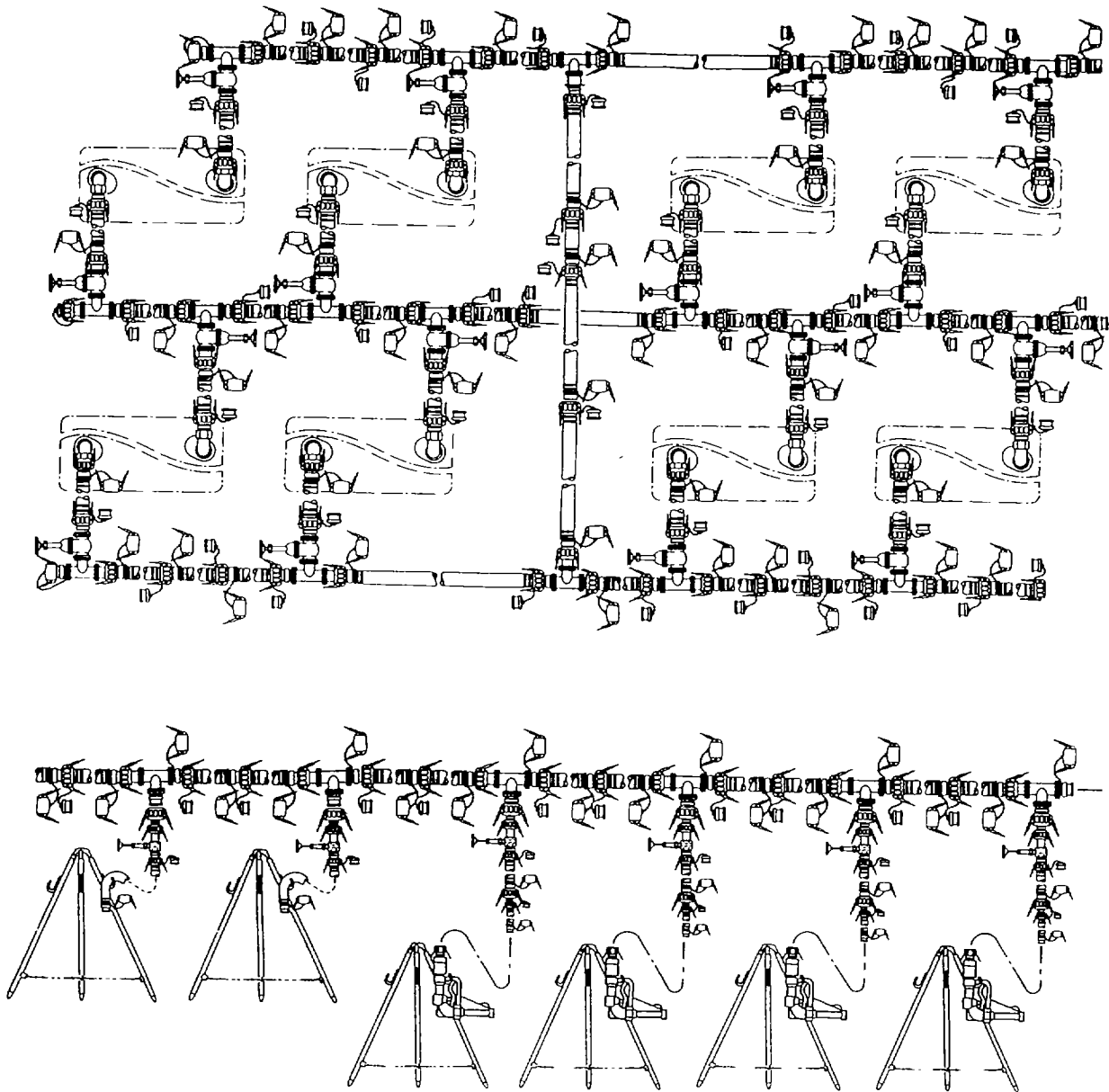

CHAPTER 1
INTRODUCTION

Paragraph		Page
Section I	General Information	1-1
1-1	Scope	1-1
1-2	Maintenance Forms, Records and Reports.....	1-1
1-3	Corrosion Prevention and Control (CPC).....	1-1
1-4	Destruction of Army Materiel to Prevent Enemy Use.....	1-2
1-5	Reporting Equipment Improvement Recommendations (EIRs).....	1-2
1-6	Nomenclature Cross Reference List	1-2
1-7	List of Abbreviations.....	1-2
1-8	Glossary.....	1-2
Section II	Equipment Description and Data	1-3
1-9	Equipment Characteristics, Capabilities and Features.....	1-3
1-10	Location and Description of Major Components.....	1-4
1-11	Equipment Data	1-6
Section III	Principles of Operation	1-8
1-12	System Technical Principles of Operation	1-8

Section I. GENERAL INFORMATION

1-1. SCOPE.

This manual contains Operating instructions, Unit maintenance and Direct Support maintenance procedures required to operate and maintain the 800K Gallon Water Storage and Distribution System, Model WSDS810 and Model 800KWSDS. The purpose of the water system is receive, store and distribute potable water to individual water bags, tanker trucks and trailer mounted water tanks (water buffaloes). Differences in the configuration between Models WSDS810 and 800KWSDS are few. This manual describes Model WSDS810 as the baseline system. Where relevant, differences in the system configuration that apply to the Model 800KWSDS system are marked with the model number throughout the manual. In all cases, Model 800KWSDS components may be used in the Model WSDS810 system.

1-2. MAINTENANCE FORMS, RECORDS AND REPORTS.

Department of the Army forms and procedures used for equipment maintenance will be those prescribed by DA Pam 750-8 (The Army Maintenance Management Systems (TAMMS)).

1-3. CORROSION PREVENTION AND CONTROL (CPC).

a. Corrosion Prevention and Control (CPC) of Army Materiel is a continuing concern. It is important that any corrosion problems with this item be reported so that the problem can be corrected and improvements can be made to prevent the problem in future items.

1-3. CORROSION PREVENTION AND CONTROL cont.

- b. While corrosion is typically associated with rusting of metals, it can also include deterioration of other materials, such as rubber and plastic. Unusual cracking, softening, swelling or breaking of the materials may be a corrosion problem.
- c. If a corrosion problem is identified, it can be reported using Standard Form 368, Product Quality Deficiency Report. Using key words such as "rust", "deterioration", or "cracking" will insure that the information is identified as a CPC problem. The form should be submitted to the address specified in DA Pam 750-8.

1-4. DESTRUCTION OF ARMY MATERIEL TO PREVENT ENEMY USE

Methods and procedures for destruction of Army Materiel to prevent enemy use are covered in TM 750-244-3.

1-5. REPORTING EQUIPMENT IMPROVEMENT RECOMMENDATIONS (EIRs).

If your 800K system needs improvement, let us know. Send us an EIR. You, the user, are the only one who can tell us what you don't like about your equipment. Let us know why you don't like the design. Tell us why a procedure is hard to perform. Put it on a SF368 (Quality Deficiency Report). Mail it to us at Headquarters Commander, US Army Aviation and Troop Command, ATUN: AMSAT-I-MDO, 4300 Goodfellow Blvd., St. Louis, MO 63120-1798. We'll send you a reply.

1-6. NOMENCLATURE CROSS REFERENCE LIST

Common Name
Water Tank

Official Nomenclature
50,000 Gallon Collapsible Fabric Tank

1-7. LIST OF ABBREVIATIONS

Abbreviation
K
°F
TM
TWDS
800KWSDS

Nomenclature
Kilo (Thousand)
Degrees Fahrenheit
Technical Manual
Tactical Water Distribution System
800,000 Gallon Water Storage and
Distribution System

1-8. GLOSSARY.

Term
Hypochlorination

Description
Purification of water by combining water with a solution made from calcium hypochlorite powder.

Section II. EQUIPMENT DESCRIPTION AND DATA**1-9. EQUIPMENT CHARACTERISTICS, CAPABILITIES AND FEATURES.**a. Characteristics.

- (1) Self contained. All components required to make the system operational are supplied with the system.
- (2) Easily transportable.
- (3) Reusable containers provide storage for water tanks and components.
- (3) Quick disconnect couplings on all components allow rapid setup and take down.
- (3) Adaptable to meet varying mission and site requirements.
- (4) No external electrical power source required.

b. Capabilities and Features.

- (1) Sixteen collapsible water tanks provide a storage capacity of 800,000 gallons.
- (2) Redundant engine driven pumping systems.
- (3) No special tools required for setup or operation.
- (4) Automatic water chlorination.

1-10. LOCATION AND DESCRIPTION OF MAJOR COMPONENTS.

Refer to figure 1-1.

- a. 350 GPM Pump Connection Kits. Each connection kit consists of hoses, valves and tees to connect the 350 gpm pump, hypochlorination unit, water meter and 125 GPM pump connection kits to the water system. One 350 pump kit is installed at the water source and is used to fill the collapsible water tanks. Another 350 GPM kit is installed on the discharge side of the water tanks to pump water to the dispensing points
 - (1) 350 gpm Pump. The pump is a self-contained, engine driven centrifugal water pump. The pump is trailer mounted to aid transport and is the primary source of water delivery in the 800K water system. Refer to the applicable TM for location and description of major components on the pump.
 - (2) Hypochlorination Unit Automatically injects hypochlorite solution into water supply in direct proportion to water flow rate. Refer to the applicable TM for location and description of major components of the hypochlorination unit.
 - (3) Water Meter. Turbine type meter measures total water flow through 350 connection kit.
- b. 125 GPM Pump Connection Kits. The connection kit consists of hoses, valves and tees needed to connect the 125 gpm pump and check valve to the 350 gpm pump connection kit. One 125 gpm pump kit is connected to each 350 gpm pump connection kit. The 125 gpm pump may be used as a spare to back up the 350 gpm pump or used by itself when reduced water pumping capacity is needed. The 125 gpm pump may also be used with the 350 gpm pump to increase pumping capacity.
 - (1) 125 gpm pump. The 125 gpm, engine driven, centrifugal water pump is skid mounted with handles at both ends to aid lifting and positioning. Refer to the applicable TM for location and description of major components on the pump
 - (2) Check Valve. In line check valve prevents back flow of water through the 125 gpm pump during pumping operations.
- c. Dual Tank Connection Kits. The dual tank connection kit consists of hoses, valves and tees needed to connect the 50K collapsible water tanks to the water system. Hand operated gate valves are used to control water flow to and from each tank A total of eight dual tank connection kits are used to connect the 16 water tanks. Each tank can store up to 50,000 gallons of potable water. The tanks expand and become pillow shape when filled. Handles on the sides of the tank aid movement and positioning of tank during setup and take down. Each tank is supplied with a ground cloth, couplings, vent tubes, elbows and drain valve. Refer to the applicable TM for location and description of major components on the water tanks.
- d. 4-inch Interconnection Kits. The interconnection kit consists of hoses and tees and is used to provide additional control of water tank filling and discharge operations. Two interconnection kits are used in the system.

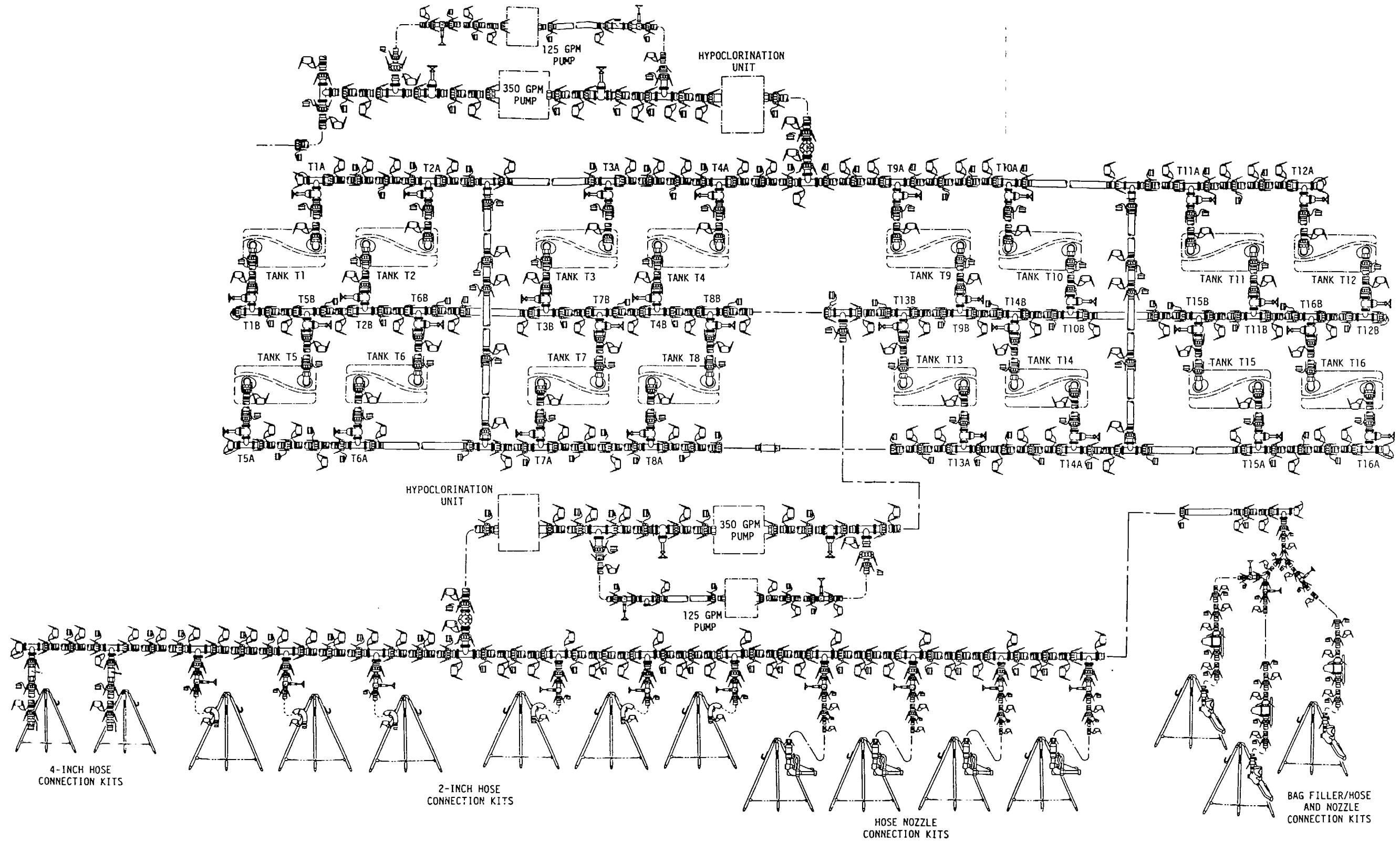

Figure 1-1. 800K Water Storage and Distribution System

1-10. LOCATION AND DESCRIPTION OF MAJOR COMPONENTS - cont.

- e. 4-inch Hose Connection Kits. The connection kits consist of 4-inch diameter hoses, tees, couplings and valves needed to connect and dispense water to semi-truck mounted water tanks. Hand operated butterfly and quick acting ball valves are used to control water flow to the transport container. Two 4-inch hose connection kits are used in the water system.
- e.1. 4-inch Hose Connection Kits (Model 800KWSDS). Model 800KWSDS 4-inch hose kits are the same as described above except the quick acting ball valve used to control water flow to the transport container is replaced by a 4-inch gate valve. A 20-foot suction hose is also added to ease filling of the transport container.
- f. 2-inch Hose Connection Kits. The connection kits consist of hoses, tees, couplings and valves needed to connect and dispense water to trailer mounted water tanks (water buffaloes) and other large containers. Hand operated gate valves are used to control water flow to the transport container. Six 2-inch hose connection kits are used in the water system.
- g. Hose Nozzle Connection Kits. The connection kits consist of hoses, tees, couplings, reducers, valves and distribution nozzles to dispense water to large portable water containers. Hand operated distribution nozzles and gate valves are used to control water flow to the containers. Each nozzle is equipped with a swivel coupling to ease operation. Nozzle stands are provided to prevent dirt, sand and contamination from entering the distribution nozzles. Four hose nozzle connection kits are used in the water system.
- h. Bag Filler Connection Kits. The bag filler connection kit consists of hoses, tees, couplings, reducers, gate valves and wye fittings needed to connect the hose and nozzle kits to the water system. Each branch of the bag filler connection kit connects to one hose and nozzle kit. Gate valves on each leg of the connection kit control water flow to the three nozzle kits. One bag filler connection kit is used in the water system.
- i. Hose and Nozzle Kits. The hose and nozzle kits consist of hoses, reducers, distribution nozzles and water pressure regulators. The hand operated distribution nozzles are used to control water flow to the container. Nozzle stands are provided to prevent dirt, sand and contamination from entering the distribution nozzles. Four hose nozzle connection kits are used in the water system.
- j. Water Tank Chest. Skid-mounted reusable storage chest will hold one 50K collapsible water tank. The four sides and top are removable to aid packing and unpacking. Internal straps secure water tanks in place.
- k. Triple Container. The container is a rigid steel frame storage container with two hinged doors. The containers are used to store and transport the water system components. Twelve containers are supplied with each water system.

1-11. EQUIPMENT DATA. (Refer to Table 1-1).

NOTE

The following equipment data is provided for system interface only and may not be accurate for the equipment supplied with your system. Refer to the applicable equipment TM for specific equipment data.

HYPOCHLORINATION UNIT

Weight (dry)	241 pounds
Length	33 inches
Width	26 inches
Height	28 inches
Chemical Tank Capacity	6 gallons
Flow Rate.....	0-350 gallons per minute

350 GPM PUMP

Length (towbar extended)	122 inches
Width	70 inches
Weight (dry)	2140 pounds
Tire Pressure	40 pounds per square inch
Fuel	Diesel, JP-4 or JP-8
Output.....	350 gallons per minute at 250 ft. head
Working Pressure	125 pounds per square inch

125 GPM PUMP

Length.....	22 inches
Width	18 inches
Weight (dry)	146 pounds
Fuel	Gasoline/Diesel
Output	125 gallons per minute at 50 foot head

1-11. EQUIPMENT DATA (Refer to Table 1-1) - cont

Table 1- 1. Equipment Data - cont

50K COLLAPSIBLE WATER TANK

Length (empty).....	65 feet
Width (empty)	25 feet
Height (full)	5 feet
Weight (empty)	1,600 pounds
Capacity.....	50,000 gallons

WATER TANK CHEST

Length	14 feet
Width	44inches
Height	36 inches
Weight (gross).....	2,200 pounds
Capacity.....	1,000 pounds

TRIPLE CONTAINER

Length	96 inches
Width	77.5 inches
Height	96 inches
Gross Weight	15,700 pounds
Tare	2,500 pounds
Volume	360 cubic feet

Section III. PRINCIPLES OF OPERATION

1-12. SYSTEM TECHNICAL PRINCIPLES OF OPERATION.

- a. General. The 800K water distribution system described in this manual is configured for maximum storage and distribution capacity. Your operating requirements will determine how many of the system components must be connected and in what configuration. Additional components are available in the accessory kit to adapt the system to varying site and operational needs. Water is supplied to the 800K system by the Tactical Water Distribution System pipeline or other source
- b. 350 and 125 GPM Pump Connection Kits (Water Source). Water is supplied to the 350 GPM pump connection kit through a trunk line or external water source. The 350 gpm kit draws water from the source and pumps it through the dual tank connection kits to the 50K collapsible tanks.

The 350 and 125 gpm water pumps are connected in parallel and provide the required water flow to the dual tank connection kit. When water demand is less than the capacity of both pumps, one pump can be shut down and the related pump valves closed. A check valve installed on the discharge side of the 125 gpm pump prevents back flow and recirculation of water in the 350 gpm kit when the 125 gpm pump is shutdown. For detailed water pump principles of operation, refer to the applicable TMs for the 125 and 350 gpm pumps.

Water from the 350 gpm kit is measured by the water meter assembly. A dial on top of the meter indicates the total number of gallons that have flowed through the meter since in operation. The meter cannot be reset. Initial meter indications at startup must be recorded, then subtracted from the total water flow measurement to get the net (current) water flow.

Water discharging from the 350 gpm kit is treated with a hypochlorite solution by the hypochlorination unit. The solution is injected into the water supply based on the water flow rate. The water supply must be tested and the hypochlorination unit adjusted to provide the correct ratio of hypochlorite solution as required by medical personnel. Refer to the applicable TM for additional information on the hypochlorination unit.

- c. Dual Tank Connection Kit. Water flow from the 350 gpm connection kit to the 50K collapsible water tanks is controlled by opening or closing the gate valves on the inlet (fill) side of the dual tank connection kit. The tanks may be filled at the same time or filled separately, depending on the operating requirements. Water is stored in the tanks until needed, then gate valves on the discharge side of the dual tank connection kit are opened to allow water flow from the tanks.
- d. 4-Inch Interconnection Kit. The interconnection kit joins the inlet (fill) hoses of the dual tank connection kits to permit water transfer between two rows of tanks.
- e. 350 and 125 GPM Pump Connection Kits (Water Dispensing Point). Water flows from the storage tanks, through the dual tank connection kits, to the suction side of the second 350 gpm and 125 pump connection kits located at the water dispensing point. The pumps are connected in parallel and supply water on demand at a rate determined by the nozzles, discharge hoses, or bag filler connections.

*U.S. GOVERNMENT PRINTING OFFICE:1995-655-121/20236

1-12. SYSTEM TECHNICAL PRINCIPLES OF OPERATION - cont.

Discharge water is treated by the hypochlorination unit before arriving at the loading stations. The hypochlorination unit mixes a hypochlorite solution with the water in correct proportion to water flow. For detailed hypochlorination unit principles of operation, refer to the applicable TM.

- f. Loading Stations (Hose Kits) Loading stations dispense water to field users through quick disconnect discharge hoses or distribution nozzles. Water flow through the loading stations is controlled by hand operated gate valves and/or distribution nozzles.

1-12. SYSTEM TECHNICAL PRINCIPLES OF OPERATION - cont.

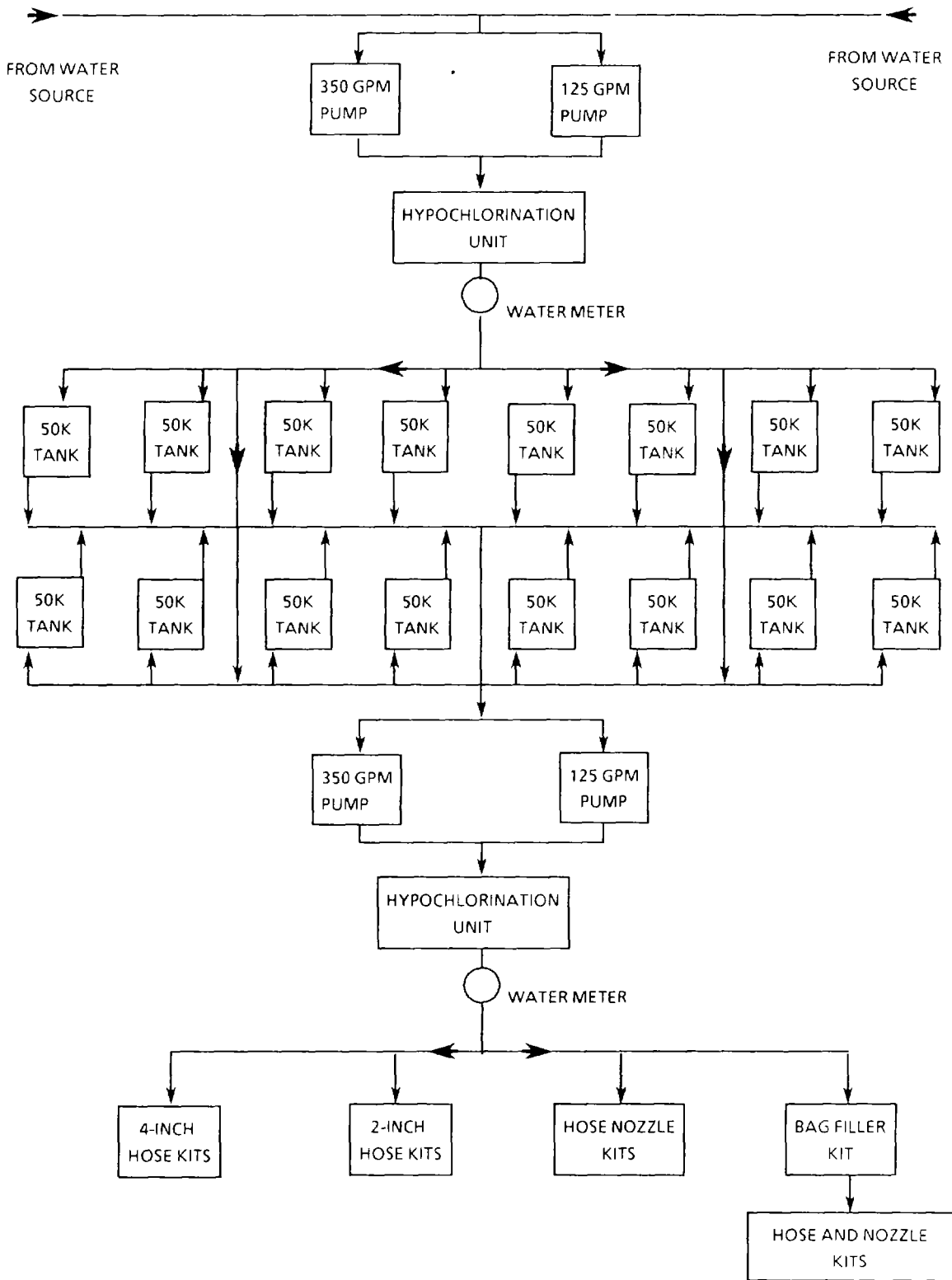

Figure 1-2. Flow Diagram

CHAPTER 2
OPERATING INSTRUCTIONS

Paragraph		Page
Section I	Description and Use of Operator's Controls and Indicators	2-1
2-1	Gate Valves	2-2
2-2	Distribution Nozzles	2-3
2-3	Water Meters	2-4
2-4	Quick Acting Valves	2-5
2-5	Butterfly Valves	2-6
Section II	Operator's Preventive Maintenance Checks and Services (PMCS)	2-7
2-6	General.....	2-7
2-7	PMCS Procedures.....	2-7
2-8	Leakage Definitions for Operator PMCS.....	2-8
2-9	Operator Preventive Maintenance Checks and Services	2-10
Section III	Operation Under Usual Conditions	2-27
2-10	Assembly and Preparation for Use	2-27
2-11	Initial Adjustment	2-62
2-12	Operating Procedures	2-62
2-13	Decals and Instruction Plates	2-66
2-14	Operating Auxiliary Equipment	2-68
2-15	Preparation for Movement.....	2-68
Section IV	Operation Under Unusual Conditions	2-93
2-16	Operation in Extreme Cold (Below 32°F).....	2-93
2-17	Operation in Extreme Heat	2-94
2-18	Operation in Dusty or Sandy Areas	2-95
2-19	Operation in Salt Water Areas	2-95
2-20	Emergency Procedures.....	2-96
2-21	General Cleaning and Decontamination.....	2-97

**Section I. DESCRIPTION AND USE OF OPERATOR'S
CONTROLS AND INDICATORS**

This section provides the operator with information needed to locate, identify, and use the controls and indicators on the 800K Water Storage and Distribution System. The components and controls identified in this section are applicable to the entire system. Many of the controls are used repeatedly throughout the system.

Various models of 350 gpm pumps, 125 gpm pumps, hypochlorination units, and 50K collapsible fabric tanks can be supplied with your water system. Refer to the applicable technical manuals for specific information on this equipment.

Refer to TM55-8145-200-13&P for description and use of operator's controls and indicators on the Tricon.

2-1. GATE VALVES.

Figure 2-1. 2-Inch and 4 Inch Gate Valves.

Handwheel (2-Inch Gate Valve)

Handwheels on the 2-inch gate valves are used to open or close the valve. Turning the handwheel all the way to the right closes the valve; to the left opens the valve. The 2-inch gate valves are used in the 125 gpm pump, 2-inch hose, hose nozzle, and bag filler connection kits to control and direct the flow of water.

Handwheel (4-Inch Gate Valve)

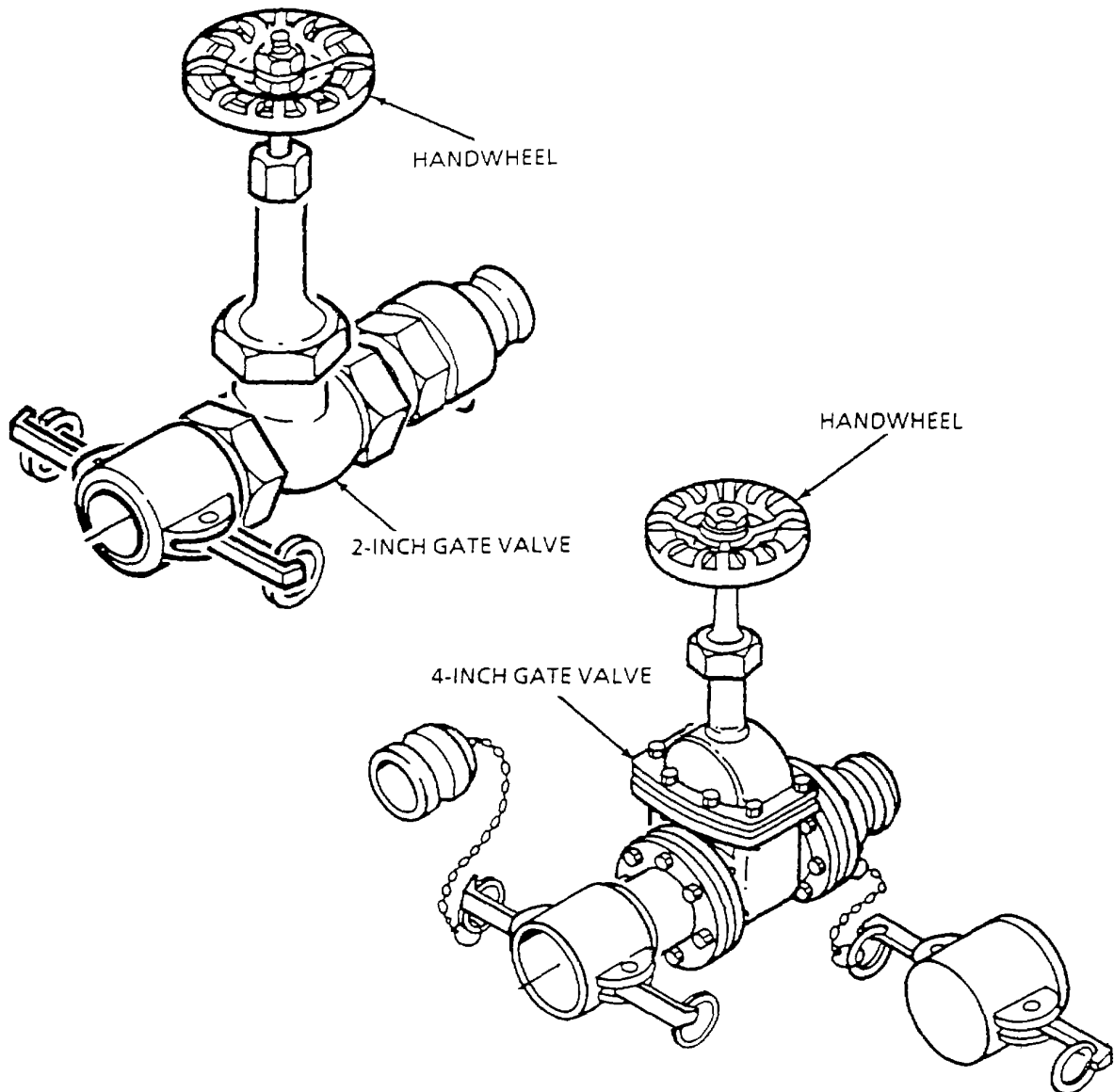
Handwheels on the 4-inch gate valves are used to open or close the valve. Turning the handwheel all the way to the right closes the valve; to the left opens the valve. The 4-inch gate valves are supplied with quick disconnect couplings for direct connection to the water system and as part of the dual tee and gate valve assemblies. The valves are used in the 350 gpm pump connection kits, dual tank connection kits and 4-inch hose connection kits (Model 80OKWSDS) to control and direct the flow of water.

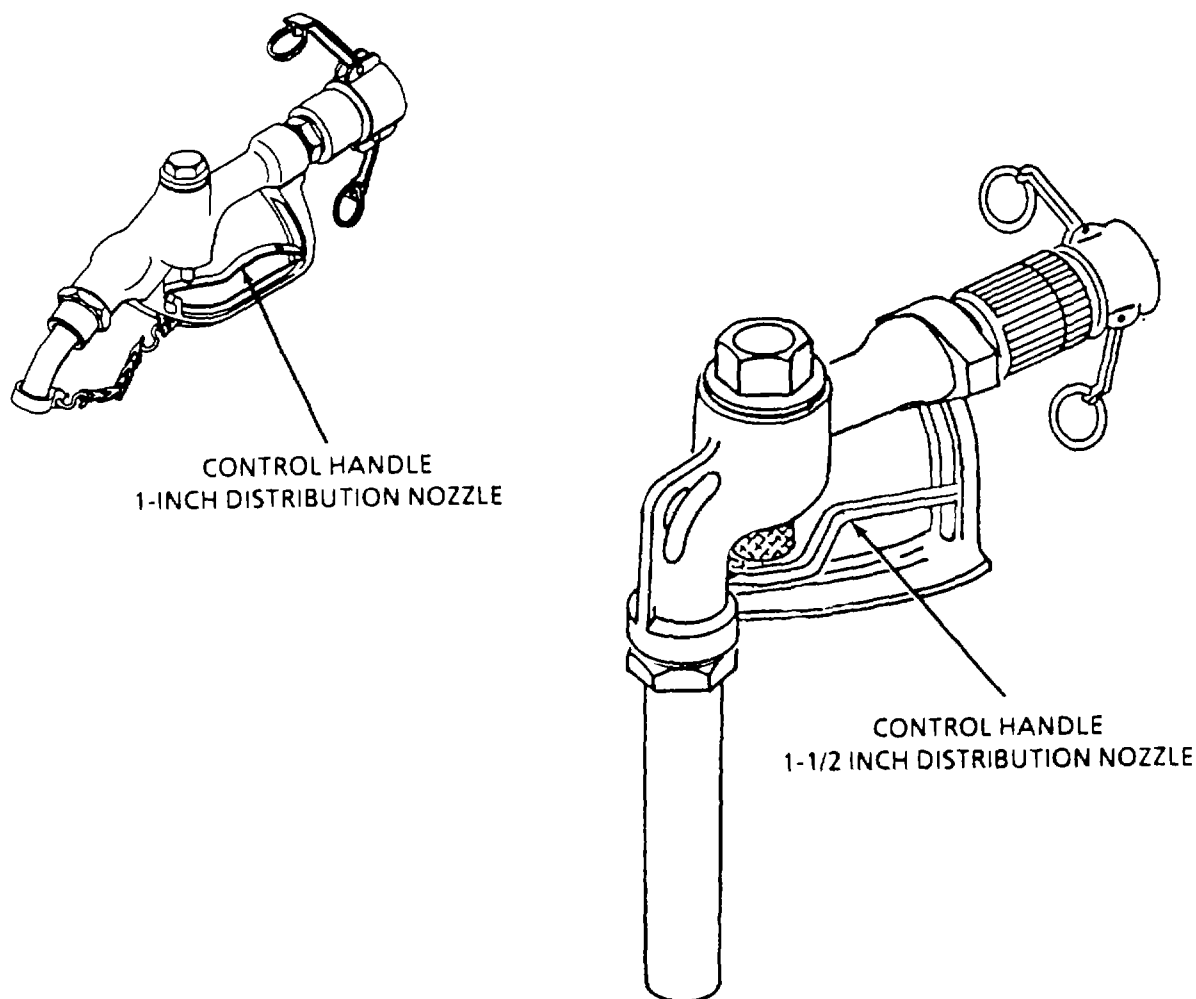
2-2. DISTRIBUTION NOZZLES.**Figure 2-2. 1-Inch and 1 1/2-Inch Distribution Nozzles.****Distribution Nozzle Handle (1-inch).**

The 1-inch distribution nozzles are operated by gripping the nozzle body and pulling up (squeezing) on the spring loaded control handle. Squeezing the handle opens an internal poppet valve and allows water flow through the nozzle. Releasing the handle stops water flow. The 1-inch distribution nozzles are used in the hose and nozzle kits.

Distribution Nozzle Handle (1-1/2 inch)

The 1-1/2-inch distribution nozzles are operated by gripping the nozzle body and pulling up (squeezing) on the spring loaded control handle. Squeezing the handle opens an internal poppet valve and allows water flow through the nozzle. Releasing the handle stops water flow. The 1 1/2 inch distribution nozzles are used in the hose nozzle connection kits.

2-3. WATER METERS.

Figure 2-3. Water Meters.

Water Meter - Indicator

The water meter indicator is located on top of the water meter and is protected by a cover. Lifting the cover reveals the face of the water meter indicator. The indicator shows the total number of gallons of water that have gone through the meter. The indicator cannot be reset. Water meters are used in both of the 350 gpm pump connection kits.

2-4. QUICK ACTING VALVES.**Figure 2-4. Quick Acting Valves.****Control Handle**

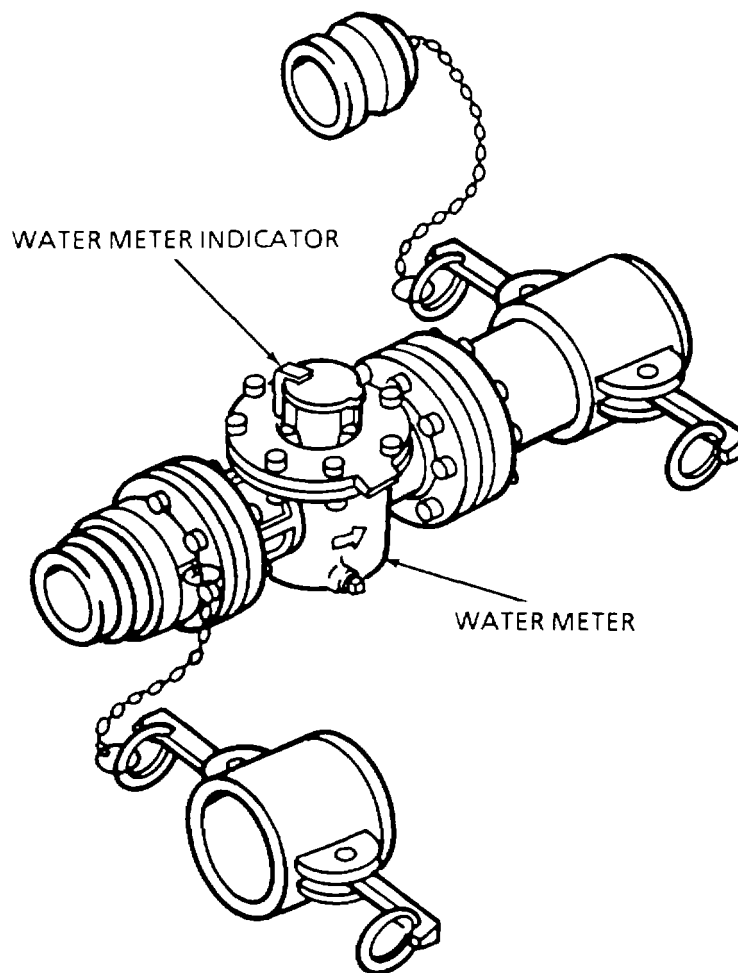
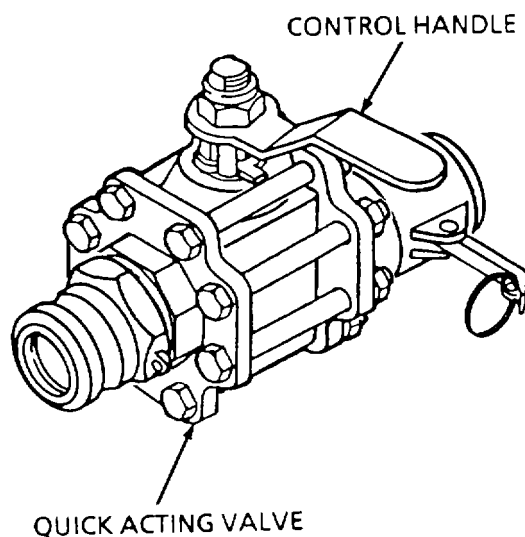
The quick acting valves control water flow through the 4-inch hose connection kits. Positioning the control handle in line with the valve body opens the valve. Positioning the handle away from the valve body closes the valve. Rotation of the valve handle is limited to 1/4 turn (90°).

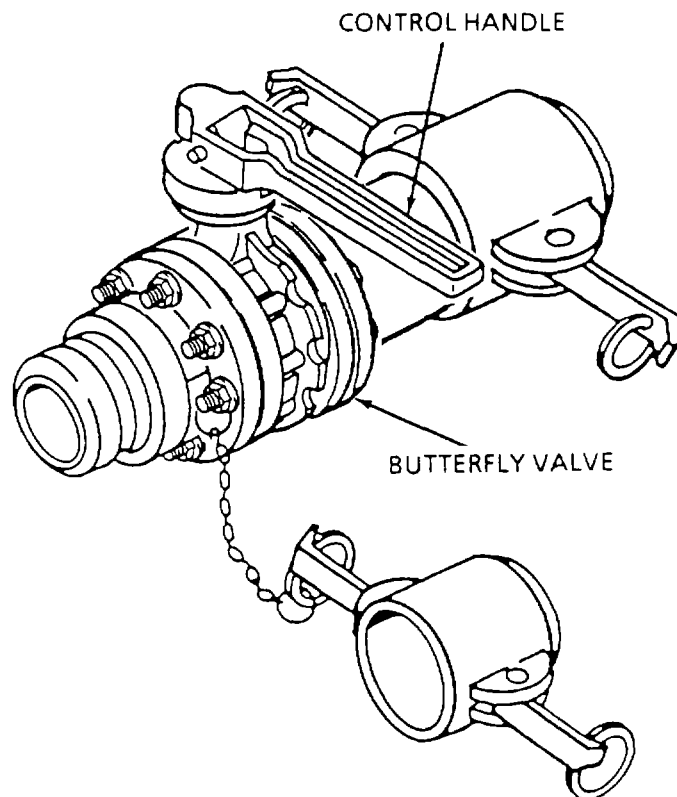
2-5. BUTTERFLY VALVES.**Figure 2-5. Butterfly Valves.****Control Handle**

The butterfly valves control water flow through the 4-inch hose connection kits. Turning the control handle in line with the valve body opens the valve. Positioning the handle out (90°) from the valve body closes the valve. Detents on top of the valve body lock the control handle in position. To change positions, push down on the control handle, rotate handle, and release. Make sure handle engages the detents in top of the valve body. Rotation of the valve handle is limited to 1/4 turn (90°).

Section II. OPERATOR PREVENTIVE MAINTENANCE CHECKS AND SERVICES (PMCS)

2-6. GENERAL.

Preventive Maintenance Checks and Services (PMCS) means systematic caring, inspecting and servicing of equipment to keep it in good condition and to prevent breakdowns. As the operator of the 800K Water Storage and Distribution System, your mission is to.

- a. Be sure to perform your PMCS each time you operate the 800K Water Storage and Distribution System. Always do your PMCS in the same order, so it gets to be a habit. Once you've had some practice, you'll quickly spot anything wrong.
- b. Do your BEFORE (B) PMCS just before you operate the equipment. Pay attention to WARNINGS, CAUTIONS and NOTES.
- c. Do your DURING (D) PMCS while you operate the equipment. During operation means to monitor the equipment and its related components while it is actually being operated. Pay attention to WARNINGS, CAUTIONS and NOTES.
- d. Do your AFTER (A) PMCS right after operating your equipment. Pay attention to WARNINGS, CAUTIONS and NOTES.
- e. Use DA Form 2404 (Equipment Inspection and Maintenance Worksheet) to record any faults that you discover before, during, or after operation, unless you can fix them. You DO NOT need to record faults that you fix.
- f. **Be** prepared to assist unit maintenance when required.
- g. When a check and set-vice procedure is required for both WEEKLY and BEFORE intervals, it is not necessary to do the procedure twice if the Equipment is operated during the weekly period.

2-7. PMCS PROCEDURES.

- a. Your Preventive Maintenance Checks and Services, Table 2-1, lists inspections and care required to keep your equipment in good operating condition. It is setup so you can make BEFORE (B) OPERATION checks as you walk around the equipment.
- b. The "INTERVAL" column of Table 2-1 tells you when to do a certain check or service.
- c. The "LOCATION ITEM TO CHECK / SERVICE" column of Table 2-1 tells you the name of the item to be checked or serviced and where the item is located.
- d. The "PROCEDURE" column of Table 2-1 tells you how to do required checks and services. Carefully follow these instructions. If you do not have tools, or if the procedure instructs you to, notify your supervisor.

2-7. PMCS PROCEDURES - cont.**NOTE**

Term "ready/available" and "mission capable" refer to the same status: Equipment is on hand and ready to perform its combat missions (See DA Pam 750-8)

- e. The "EQUIPMENT IS NOT READY/AVAILABLE IF" column in Table 2-1 tells you when your equipment is not mission capable and why the system cannot be used.
- f. If the equipment does not perform as required, refer to Chapter 3, Section II, Troubleshooting.
- g. If anything looks wrong and you can't fix it, write it on your DA Form 2404. IMMEDIATELY, report it to your supervisor.
- h. The following are checks that are common to the entire water system
 - (1) Keep the equipment clean. Remove dirt, sand and debris from quick disconnect couplings, hose ends, gate valves and distribution nozzles to prevent excessive wear and contamination of the water system. Use soap and water to remove dirt. Do not contaminate system with any type of cleaning solvent.
 - (2) Bolts, nuts and screws. Check them for obvious looseness, missing, bent or broken condition on gate valves. If you find a bolt, nut or screw you think is loose, tighten it or report it to your supervisor.
 - (3) Hoses. Look for wear, damage and leaks. Make sure clamps and quick disconnect couplings are tight. Wet spots show leaks, but a stain around a fitting or connector can also mean a leak. If a leak comes from a loose fitting or coupling, tighten it. If something is broken or worn out, report it to your supervisor.
- i. When you check for "operating condition", look at the component to see if it's serviceable.

2-8. LEAKAGE DEFINITIONS FOR OPERATOR PMCS.

It is necessary for you to know how fluid leakage affects the status of the equipment. Following are types and classes of leakage an operator needs to know to be able to determine the status of the water system. Learn these leakage definitions and remember when in doubt, notify your supervisor.

CAUTION

- Equipment operation is allowable with minor leakages (Class I or II). Of course, consideration must be given to fluid capacity in the system. When in doubt, notify your supervisor.
- When operating with Class I or II leaks, continue to check fluid levels as required in your PMCS.
- Class III leaks should be reported immediately to your supervisor.

- a. Class I - See page of fluid (as indicated by wetness or discoloration) not great enough to form drops.

2-8. LEAKAGE DEFINITIONS FO OPERTATOR PMCS -cont.

- b. CLASS II - Leakage of fluid great enough to form drops but not enough to cause drops to drip from item being checked/inspected.
- c. CLASS III - Leakage of fluid great enough to form drops that fall from item being checked/inspected

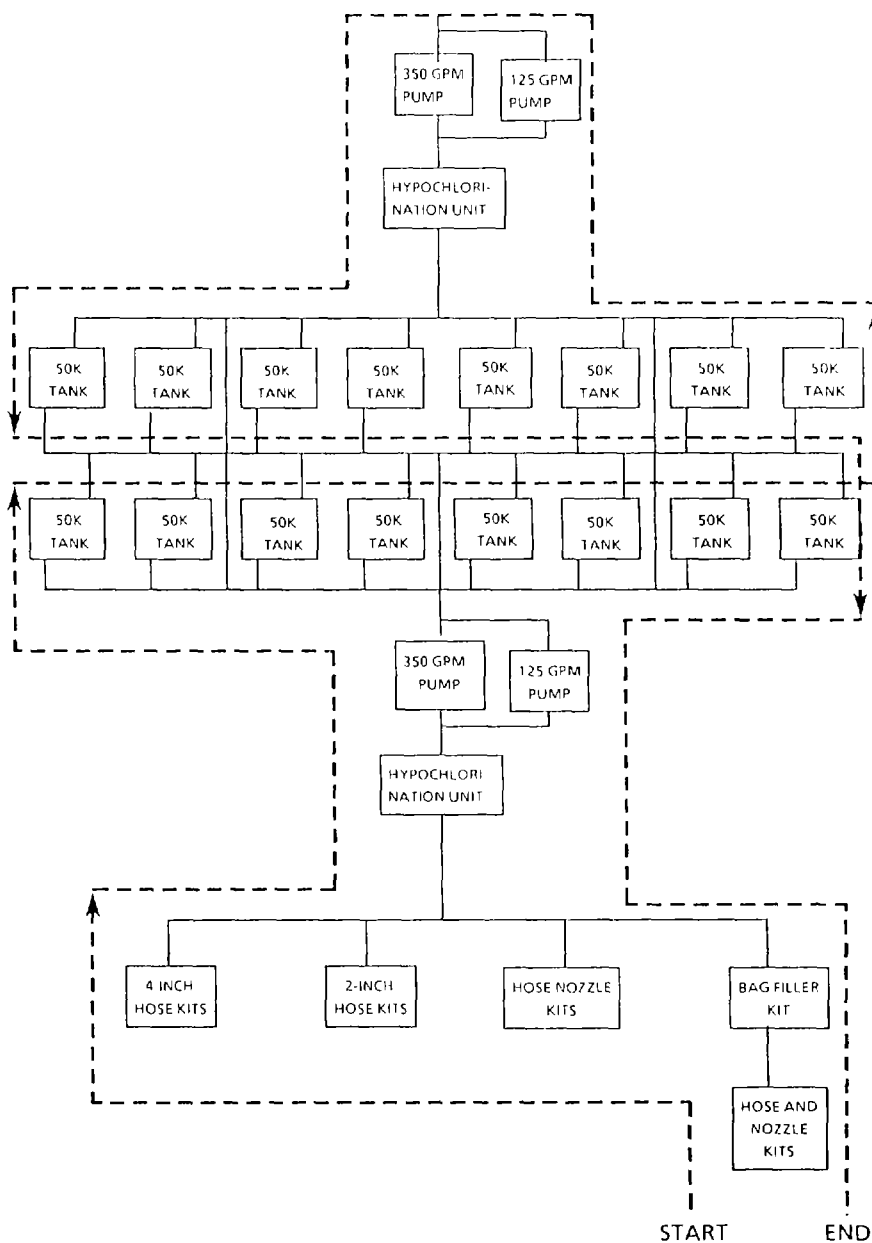

Figure 2-6. PMCS Routing Diagram

2-9. OPERATOR PREVENTIVE MAINTENANCE CHECKS AND SERVICES (Refer To Table 2-1).

Table 2-1. Operator Preventive Maintenance Checks and Services for Model WSDS-310.

NOTE

If the equipment must be kept in continuous operation, do only the procedures that can be done without disturbing operation. Make complete checks and services when the equipment is shut down.

Item No.	Interval	Location <hr/> Item to Check/Service	Procedure	Not Fully Mission Capable If:
1	Before	<u>HOSE AND NOZZLE CONNECTION KITS</u> Distribution Nozzles (1-inch)	a. Inspect for bent or damaged nozzle body and tube. b. Inspect for bent, broken, or stuck control handle.	Distribution nozzle damaged or defective.
2	Before	Discharge Hoses	a. Inspect for cuts, tears and deep abrasions. b. Inspect for cracked, bent or broken couplings. c. Check for and straighten kinked hoses.	Hoses cut or torn. Couplings cracked or broken.
3	Before	Water Pressure Regulators	Inspect regulator body and couplings for cracks.	Regulator body or couplings cracked.
4	Before	Nozzle Stands	Inspect for broken chains and bent or cracked legs. 	

Table 2-1. Operator Preventive Maintenance Checks and Services for Model WSDS-310 - cont.

Item No	Interval	Location <hr/> Item to Check/Service	Procedure	Not Fully Mission Capable If:
4	Before	<u>BAG FILLER CONNECTION KIT</u> Discharge Hoses	a. Inspect for cuts, tears and deep abrasions. b. Inspect for cracked, bent or broken couplings. c. Check for and straighten kinked hoses.	Hoses cut or torn. Couplings cracked or broken.
5	Before	Gate Valves (2-inch)	a. Inspect for loose, broken, or missing hand wheel. Rotate hand wheel. Valve should turn freely. b. Inspect valve body for cracks and external damage.	Hand wheel broken or missing Valve will not turn. Valve body cracked or damaged. Fitting bodies cracked
6	Before	Tee and Wye Assemblies	Inspect tee and wye bodies for cracks and corrosion.	Fitting bodies cracked.

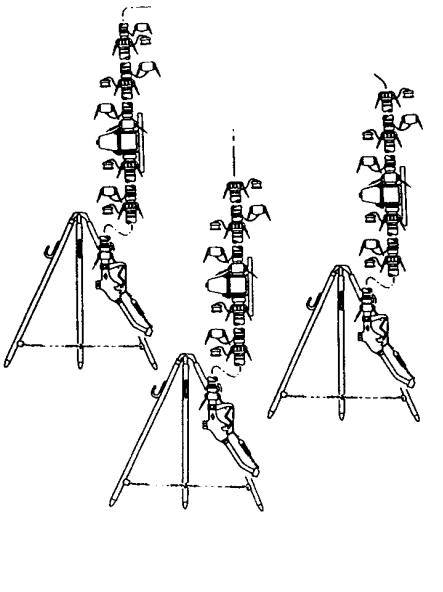
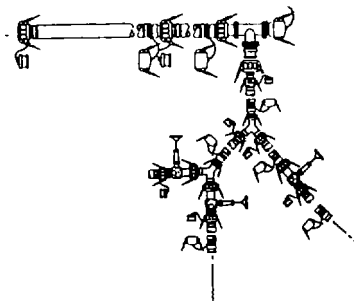

Table 2-1. Operator Preventive Maintenance Checks and Services for Model WSDS-310 - cont.

Item No	Interval	Location	Procedure	Not Fully Mission Capable If:
		Item to Check/Service		
7	Before	HOSE NOZZLE CONNECTION KIT Nozzle Stand	Inspect for broken chains, missing hardware, and bent or cracked legs	
8	Before	Distribution nozzle (1-1/2 inch)	a. Inspect for bent or damaged nozzle body and tube.. b. Inspect for bent, broken, or stuck control handle.	Distribution Nozzles damaged or defective
9	Before	Discharge Hoses	a. Inspect for cuts, tears and deep abrasions. b. Inspect for cracked and bent or broken. couplings. c. Check for and straighten kinked hoses.	Hoses cut or torn. Couplings cracked or broken
10	Before	Gate Valves (2-inch)	a. Inspect for loose, broken, or missing hand wheel. Rotate hand. wheel. Valve should turn freely. b. Inspect valve body for cracks and external damage.	Valve cracked, broken or stuck
11	Before	Tee Assemblies	Inspect tee bodies for cracks and corrosion. .	Tee bodies cracked or damaged
				

Table 2-1. Operator Preventive Maintenance Checks and Services for Model WSDS-810 - cont.

Item No	Interval	Location	Procedure	Not Fully Mission Capable If:
		Item to Check/Service		
		<u>2-Inch HOSE CONNECTION KIT</u>		
12	Before	Nozzle Stand	Inspect for broken chains, missing hardware, and bent or cracked legs	
13	Before	Discharge Hoses	a. Inspect for cuts, tears and deep abrasions. b. Inspect for cracked and bent or broken couplings. c. Check for and straighten kinked hoses	Hoses cut or torn. Coupling cracked or broken.
14	Before	Gate Valves (2-inch)	a. Inspect for loose, broken, or missing hand wheel. Rotate hand wheel. Valve should turn freely. b. Inspect valve body for cracks and external damage.	Valve cracked broken or stuck.
15	Before	Tee Assemblies	Inspect tee bodies for cracks and corrosion	Tee bodies cracked or damaged.

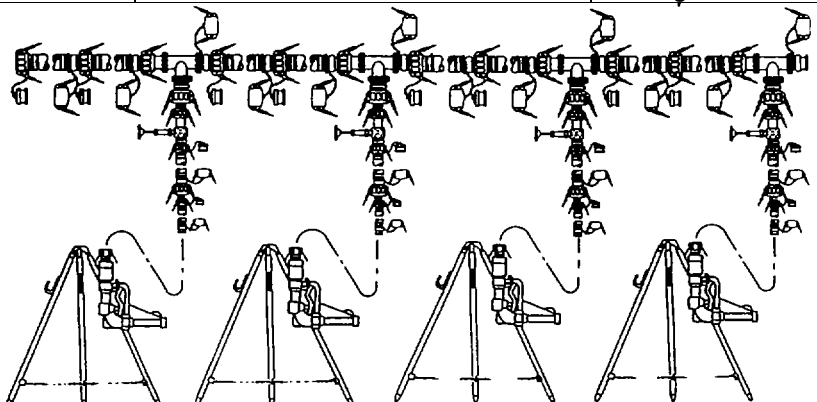
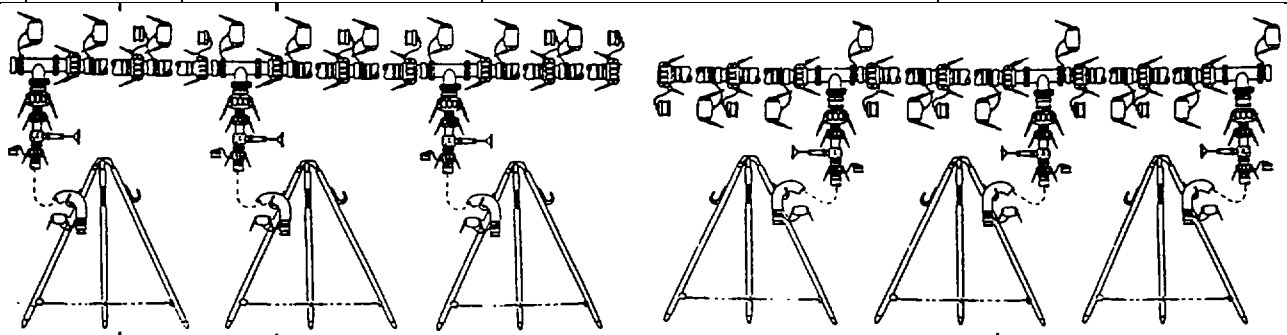

Table 2-1. Operator Preventive Maintenance Checks and Services for Model WSDS-810 - cont.

Item No	Interval	Location <hr/> Item to Check/Service	Procedure	Not Fully Mission Capable If:
16	Before	<p><u>4-INCH HOSE CONNECTION KITS</u></p> <p>Nozzle Stand</p>	<p>Inspect for broken chains, missing hardware, and bent or cracked legs</p>	
17	Before	<p>Butterfly Valves</p> <p>Discharge Hoses</p>	<p>a. Inspect for loose, broken, or missing handwheel. Rotate hand wheel. Valve should turn freely..</p> <p>b. Inspect valve body for cracks and external damage.</p> <p>a. Inspect for cuts, tears and deep abrasion.</p> <p>b. Inspect for cracked and bent or broken couplings.</p> <p>c. Check for and straighten kinked hoses</p>	<p>Hoses cut or torn. Coupling cracked or broken.</p>
18	Before	<p>Quick Acting Valves</p> <p>or</p> <p>Gate Valves (4-inch)</p>	<p>a. Inspect for loose, broken, or missing control handle. Rotate handle. Valve should turn freely</p> <p>b. Inspect valve body for cracks and external damage</p>	<p>Valve cracked broken or stuck.</p>
19	Before	Tee Assemblies	Inspect tee bodies for cracks and corrosion	Tee bodies cracked or damaged.
		 <p>MODEL 800KWSDS</p>		

Table 2-1. Operator Preventive Maintenance Checks and Services for Model WSDS-310 - cont.

Item No	Interval	Location	Procedure	Not Fully Mission Capable If:
		Item to Check/Service		
		<u>350 GPM PUMP CONNECTION KIT (DISPENSING POINT)</u>		
20	Before	Tee Assemblies	Inspect tee bodies for cracks and corrosion.	
21	Before	Water Meter	a. Inspect for cracked or broken cover or indicator b. Inspect meter body of cracks and external damage.	Tee bodies cracked or Damaged Meter body cracked or damaged Meter indicator broken.
22		Hypochlorination Unit	Perform "BEFORE" PMCS contained Unit in the applicable TM.	
23	Before	Suction and Discharge Hoses	a. Inspect for cuts, tears and deep abrasions. b. Inspect for cracked and bent or broken. couplings. c. Check for and straighten kinked hoses.	Hoses cut or torn. Couplings cracked or broken.
24	Before	Gate Valves (4-inch)	a. Inspect for loose, broken, or missing hand wheel. Rotate hand wheel. Valve should turn freely. b. Inspect valve body for cracks and external damage. c. Inspect for loose or missing hardware.	Valve cracked, broken or stuck. Hardware missing.
25		350 GPM Pump	Perform "BEFORE" PMCS contained in the applicable TM.	

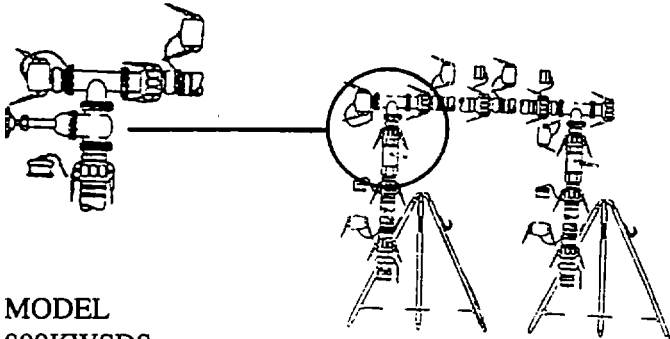
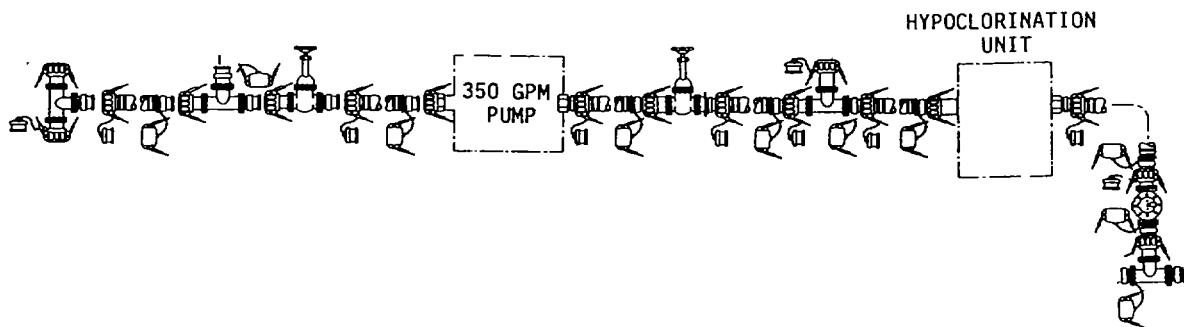

Table 2-1. Operator Preventive Maintenance Checks and Services for Model WSDS-310 - cont.

Item No	Interval	Location <hr/> Item to Check/Service	Procedure	Not Fully Mission Capable If:
26	Before	<p><u>125 GPM PUMP CONNECTION KIT (DISPENSING POINT)</u></p> <p>Suction and Discharge Hoses</p>	<p>a. Inspect for cuts, tears and deep abrasions</p> <p>b. Inspect for cracked and bent or broken couplings.</p> <p>c. Check for and straighten kinked hoses.</p>	<p>Hoses cut or torn.</p> <p>Couplings cracked or broken</p>
27	Before	<p>Gate Valves (2-inch)</p>	<p>a. Inspect for loose, broken, or missing hand wheel. Rotate hand wheel. Valve should turn freely.</p> <p>b. Inspect valve body for cracks and external damage.</p>	<p>Valve cracked, broken or stuck.</p>
28	Before	<p>Check Valve</p>	<p>Inspect valve body for cracks and external damage</p>	<p>Valve cracked or broken.</p>
29	Before	<p>125 GPM Pump</p>	<p>Perform "BEFORE" PMCS contained in the applicable TM.</p>	

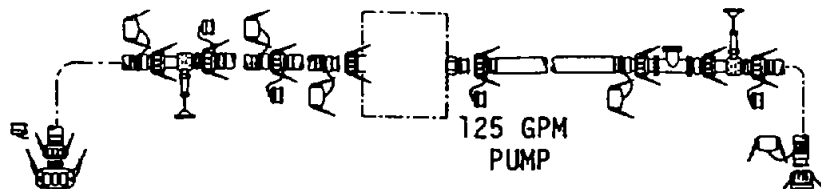

Table 2-1. Operator Preventive Maintenance Checks and Services for Model WSDS-310 - cont.

Item No	Interval	Location <hr/> Item to Check/Service	Procedure	Not Fully Mission Capable If:
30	Before	<p><u>DUAL TANK NOTE</u> <u>CONNECTION KITS</u></p> <p>Suction and Discharge hoses</p>	<p>NOTE One dual tank connection kit is shown. The others are similar.</p> <p>a. Inspect for cuts, tears and deep abrasions b. Inspect for cracked and bent or broken coupling. c. Check for and straighten kinked hoses</p>	<p>Hoses cut or torn. Couplings cracked or broken</p>
31	Before	Tee Assemblies	Inspect tee bodies for cracks and corrosion	Tee bodies cracked or damaged
32	Before	Gate Valves (4-inch)	<p>a. Inspect for loose, broken, or missing hand wheel. Rotate hand wheel. Valve should turn freely. b. Inspect valve body for cracks and external damage. c. Inspect for loose or missing hardware.</p>	Valve cracked, broken or stuck. Hardware missing.
33	Before	50K Collapsible Fabric Tanks	Perform "BEFORE" PMCS contained in the applicable TM.	

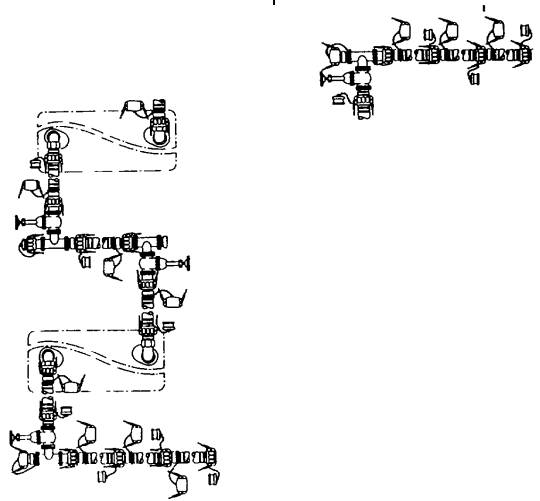

Table 2-1. Operator Preventive Maintenance Checks and Services for Model WSDS-310 - cont.

Item No	Interval	Location <hr/> Item to Check/Service	Procedure	Not Fully Mission Capable If:
34	Before	<u>INTERCONNECTION KITS</u> Suction and Discharge Hoses	NOTE One interconnection kit is shown. The other are similar a. Inspect for cuts, tears and deep abrasions b. Inspect for cracked and bent or broken couplings. c. Check for and straighten kinked hoses.	Hoses cut or torn Couplings cracked or broken
35	Before	Tee Assemblies	Inspect tee bodies for cracks corrosion.	Tee bodies cracked or damaged

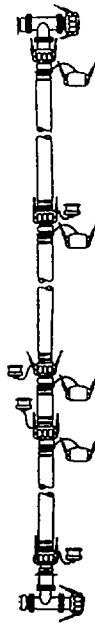

Table 2-1. Operator Preventive Maintenance Checks and Services for Model WSDS-310 - cont.

Item No	Interval	Location <hr/> Item to Check/Service	Procedure	Not Fully Mission Capable If:
35	Before	<u>350 GPM PUMP CONNECTION KIT (SOURCE)</u> Tee Assemblies	Inspect tee bodies for cracks and corrosion.	Tee bodies cracked or damaged
36	Before	WaterMeter	a. Inspect for cracked or broken cover or indicator. b. Inspect meter body of cracks and external damage.	Meter body cracked or damaged. Meter indicator broken.
37		Hypochlorination Unit	Perform "BEFORE," PMCS contained in the applicable TM.	
38	Before	Suction and Discharge Hoses	a. Inspect for cuts, tears and deep abrasions b. Inspect for cracked and bent or broken. couplings. c. Check for and straighten kinked hoses.	Hoses cut or torn. Couplings cracked or broken.
39	Before	Gate Valves (4-inch)	a. Inspect for loose, broken, or missing hand wheel. Rotate hand wheel. Valve should turn freely. b. Inspect valve body for cracks and external damage. c. Inspect for loose or missing hardware.	Valve cracked broken or stuck. Hardware missing.
40		350 GPM Pump <u>125 GPM PUMP CONNECTION KIT (SOURCE)</u>	Perform "BEFORE" PMCS contained in the applicable TM.	Hoses cut or torn.
41	Before	Suction and Discharge Hoses	a. Inspect for cuts, tears and deep abrasions. b. Inspect for cracked and bent or broken. Couplings c. Check for and straighten kinked hoses.	Couplings cracked broken couplings.

Table 2-1. Operator Preventive Maintenance Checks and Services for Model WSDS-310 - cont.

Item No	Interval	Location <hr/> Item to Check/Service	Procedure	Not Fully Mission Capable If:
42	Before	Gate Valves (2-inch)	a. Inspect for loose, broken, or missing hand wheel. Rotate hand wheel. Valve should turn freely b. Inspect valve body for cracks and external damage.	Valve cracked, broken or stuck.
43	Before	Check Valve	Inspect valve body for cracks and external damage.	Valve cracked or broken
44	Before	125 GPM Pump <u>HOSE NOZZLE CONNECTION KIT</u>	Perform "BEFORE" PMCS contained in the applicable TM.	
45	During	Distribution Nozzle	Check for leaks when control handle is released	Leaks (class III)
46	During	Discharge Hoses	a. Inspect hoses for leaks and loose or unlocked couplings. b. Check hoses for kinks. Unkink hoses	Class 111 leak.
47	During	Water Pressure Regulators BAG FILLER CONNECTION KIT	Inspect regulator body and couplings. for leaks.	Class 111 leak
48	During	Discharge Hoses	a. Inspect hoses for leaks and loose or unlocked couplings b. Check hoses for kinks. Unkink hoses.	Class III leak
49	During	Gate Valves (2-inch)	Inspect for leaking valve stems	Class III leak.
50	During	Tee and Wye Assemblies	Inspect tee and wyes for leaking leaking gaskets.	Class III leak.

Table 2-1. Operator Preventive Maintenance Checks and Services for Model WSDS-810 - cont.

Item No	Interval	Location	Procedure	Not Fully Mission Capable If:
		Item to Check/Service		
51	During	<u>HOSE NOZZLE CONNECTION KIT</u>	Check for leaks when control handle is released	Leaks (class III))
		Distribution Nozzle		
52	During	Discharge Hoses	a. Inspect hoses for leaks and loose or unlocked couplings. b. Check hoses for kinks. Unkink hoses.	Class III leak.
53	During	Gate Valves (2-inch)	Inspect for leaking valve stems.	Class III leak.
54	During	Tee Assemblies	Inspect tees for leaking gaskets.	Class II leak.
55	During	<u>2-INCH HOSE CONNECTION KIT</u>	a. Inspect hoses for leaks and loose or unlocked couplings. b. Check hoses for kinks. Unkink hoses.	Class III leak.
		Discharge Hoses		
56	During	Gate Valves (2-inch)	Inspect for leaking valve stems.	Class III leak.
57	During	Tee Assemblies	Inspect tees for leaking gaskets	Class III leak.
58	During	<u>4-INCH HOSE CONNECTION KITS</u>	Inspect for leaks at valves stem;	Class III leak
		Butterfly Valves		
59	During	Quick Acting Valves or Gate Valves (4-inch)	Inspect for leaks at valve stems and or valve body gaskets	Class III leak.
60	During	Tee Assemblies	Inspect tees for leaking gaskets.	Class III leak
61	During	<u>350 GPM PUMP CONNECTION KIT (DISPENCING POINT)</u>	Inspect tees for leaking gaskets	Class III leak.
		Tee Assemblies		
62	During	Water Meter	Check for proper operation of meter indicator.	

Table 2-1. Operator Preventive Maintenance Checks and Services for Model WSDS-810 - cont.

Item No	Interval	Location	Procedure	Not Fully Mission Capable If:
		Item to Check/Service		
63	During	Hypochlorination Unit	Perform "DURING" PMCS contained in the applicable TM.	
64	During	Suction and Discharge Hoses	a. Inspect hoses for leaks and loose or unlocked couplings. b. Check hoses for kinks. Unkink hoses.	Class III leak.
65	During	Gate Valves (4-inch)	Inspect for leaking valve stems.	Class III leak .
66	During	350 GPM Pump <u>125 GPM PUMP CONNECTION KIT (DISPENSING POINT)</u>	Perform "DURING" PMCS contained in the applicable TM.	
67	During	Suction and Discharge Hoses	a. Inspect hoses for leaks and loose or unlocked couplings. b. Check hoses for kinks. Unkink hoses.	Class III leak.
68	During	Gate Valves (2-inch)	Inspect for leaking valve stems.	Class III leak .
69	During	Check Valve	Inspect valve body for leaks.	Class III leak.
70	During	125 GPM Pump <u>DUAL TANK CONNECTION KITS</u>	Perform "BEFORE" PMCS contained in the applicable TM.	
71	During	Suction and Discharge Hoses	a. Inspect hoses for leaks and loose unlocked couplings. b. Check hoses for kinks. Unkink hoses.	Class III leak
72	During	Tee Assemblies	Inspect tees for leaking gaskets.	Class III leak
73	During	Gate Valves (4-inch)	Inspect for leaking valve stems.	Class III leak
74	During	50K Collapsible Fabric Tanks	Perform "DURING" PMCS contained in the applicable TM.	

Table 2-1. Operator Preventive Maintenance Checks and Services for Model WSDS-310 - cont.

Item No	Interval	Location	Procedure	Not Fully Mission Capable If:
		Item to Check/Service		
		<u>INTERCONNECTION KITS</u>		
75	During	Suction and Discharge hoses	a. Inspect hoses for leaks and loose or unlocked couplings. b. Check hoses for kinks. Unkink hoses.	Class III leak.
76	During	Tee Assemblies <u>350 GPM PUMP CONNECTION KIT (SOURCE)</u>	Inspect tees for leaking gaskets.	Class III leak.
77	During	Tee Assemblies	Inspect tees for leaking gaskets.	Class III leak.
78	During	Water Meter	Check for operation of meter indicator.	Class III leak.
79	During	Hypochlorination Unit	Perform "During" PMCS contained in the applicable TM.	Class III leak.
80	During	Suction and Discharge Hoses	a. Inspect hoses for leaks and loose or unlocked couplings. b. Check hoses for kinks. Unkink hoses.	Class III leak.
81	During	Gate Valves (4-inch)	Inspect for leaking valve stems.	
82	During	350 GPM Pump <u>125 GPM PUMP CONNECTION KIT (DISPENSING POINT)</u>	Perform "DURING" PMCS contained in the applicable TM	
83	During	Suction and Discharge Hoses	a. Inspect hoses for leaks and loose or unlocked couplings. b. Check hoses for kinks. Unkink hoses.	Class III leak.
84	During	Gate Valves (2-inch)	C Inspect for leaking valve stems. Inspect valve body for leaks.	Class III leak.
85	During	Check Valve		
86	During	125 GPM Pump	Perform "DURING" PMCS contained in the applicable TM.	Class III leak.

Table 2-1. Operator Preventive Maintenance Checks and Services for Model WSDS-310 - cont.

Item No	Interval	Location	Procedure	Not Fully Mission Capable If:
		Item to Check/Service		
		<u>WATER SYSTEM</u>		
87	After	Suction and Discharge Hoses	a. Inspect quick disconnect couplings for damage and missing gasket caps, or plugs. b. Inspect for missing attaching bolts, nuts and hardware. c. Inspect for torn, punctured or damaged hoses.	Couplings damaged; gasket damaged or missing; hose punctured or torn.
88	After	Gate Valves	a. Inspect quick disconnect couplings for damage and missing gasket ,caps, or plugs b. Inspect for missing attaching bolts, nuts and hardware.	Coupling damaged; gasket damaged or missing; hardware missing.
89	After	Tee and Assemblies	a. Inspect quick disconnect couplings for damage and missing gasket, caps, or plugs. b. Inspect for missing attaching bolts, nuts and hardware.	Coupling damaged; gasket damaged or missing; hardware missing.
90	After	Distribution Nozzles	a. Inspect quick disconnect couplings for damage and missing gasket,; caps, or plugs. b. Check for missing nozzle tube caps.	Coupling damaged; gasket damaged or missing hardware missing.
91	After	Water Pressure Regulators	a. Inspect quick disconnect couplings for damage and missing gasket, caps, or plugs. b. Inspect for missing attaching bolts, nuts and hardware.	
92	After	Butterfly Valves	a. Inspect quick disconnect couplings for damage and missing gasket, caps, or plugs. b. Inspect for missing attaching bolts, nuts and hardware.	
93	After	Quick Acting Valves	a. Inspect quick disconnect couplings for damage and missing gasket, caps, or plugs. c. Inspect for missing attaching bolts, nuts and hardware.	

Table 2-1. Operator Preventive Maintenance Checks and Services for Model WSDS-310 - cont.

Item No	Interval	Location	Procedure	Not Fully Mission Capable If:
		Item to Check/Service		
94	After	Water Meters	<ul style="list-style-type: none"> a. Inspect quick disconnect couplings for damage and missing gasket, caps, or plugs. b. Inspect for missing attaching bolts, nuts and hardware. c. Inspect for cracked or damaged meter indicator. 	
95	After	Check Valves	<ul style="list-style-type: none"> a. a. Inspect quick disconnect couplings for damage and missing gasket, caps, or plugs. b. Inspect for missing attaching bolts, nuts and hardware. 	
96	After	Water Tank Chests	<ul style="list-style-type: none"> a. Inspect for missing attaching Chests bolts, nuts and hardware. b. Inspect top and side panels for cracks and punctures. c. Inspect skid frame for cracked weldments and missing hardware. 	
97	After	125 GPM Pump		
98	After	350 GPM Pump	Perform "AFTER" PMCS contained in the applicable TM.	
99	After	50K Collapsible Fabric Tanks	Perform "AFTER" PMCS contained in the applicable TM.	
100	After	Hypochlorination Unit	Perform "AFTER" PMCS contained in the applicable TM.	
101	After	Triple Container	<p>Perform "AFTER" PMCS contained in the applicable TM.</p> <p>Perform "AFTER" PMCS contained in TM55-8145-200-13&P.</p>	

Section III. OPERATION UNDER USUAL CONDITIONS

2-10. ASSEMBLY AND PREPARATION FOR USE.a. Site Selection.**NOTE**

This manual covers installation of all connection kits, but you may not need all these components to perform your mission. You may adjust the number of components used and their position in the system to meet your operating requirements.

- (1) Select a level, debris free installation area. Site requirements must consider location of water source and distribution points. Site must be large enough to contain all system components (minimum 260 x 275 feet).
- (2) Position twelve tricons and eight water tank storage chests near installation site.

b. Unpacking.

- (1) Open twelve tricon containers. Refer to TM55-8145-200-13&P.
- (2) Unpack contents of each container. To aid assembly, separate components into groups of similar parts during removal. For example, group all the 4-inch discharge hoses together, then all the 4-inch gate valves, 2-inch discharge hoses and so on until all components are unpacked.
- (3) Unpack Hypochlorination unit. Refer to the applicable TM.
- (4) Unpack 125 GPM pumps. Refer to the applicable TM.
- (5) Unpack 350 GPM pumps. Refer to the applicable TM.

c. Quick Disconnect Couplings. Refer to figure 2-7.

All components of the 800K Water Storage and Distribution System are equipped with quick disconnect couplings to permit rapid assembly and disassembly of components. The following instructions apply to all operator installation and removal tasks.

WARNING

To prevent injury to personnel and damage to the equipment, use care when connecting coupling to avoid getting dirt, sand and debris on coupling mating surfaces or in hoses. To prevent leaks and ensure tight connections, make sure gaskets are installed in all female quick disconnect couplings.

CONNECTION

- (1) Lift locking arms (1) up and out from female coupling (2).
- (2) Remove plug (3) from female coupling (2).
- (3) Lift locking arms (4) up and out from cap (5).

2-10. ASSEMBLY AND PREPARATION FOR USE - cont.

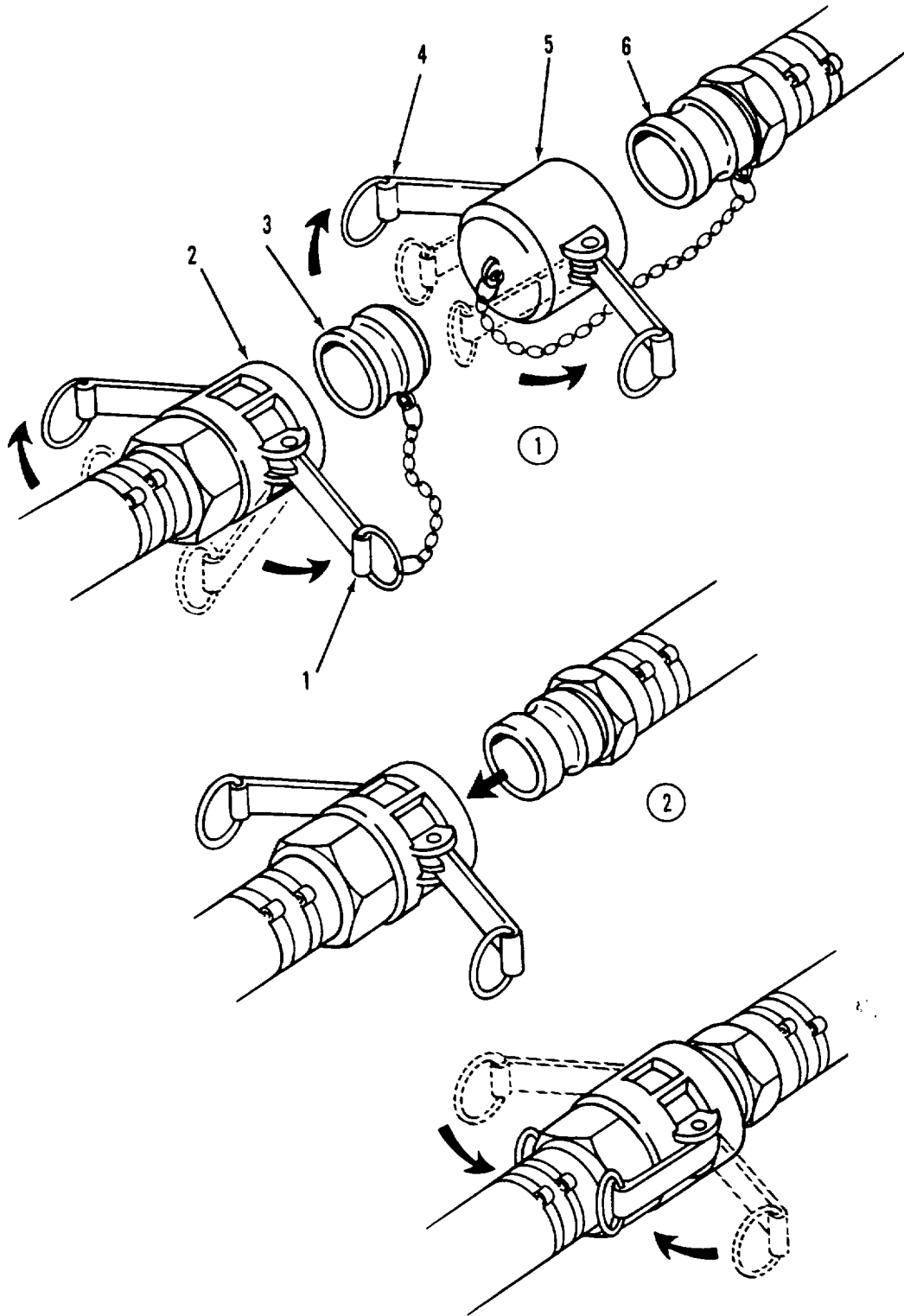

Figure 2-7. Quick Disconnect Couplings.

2-10. ASSEMBLY AND PREPERATION FOR USE - cont.

- (4) Remove cap (5) from male coupling (6).
- (5) Position male coupling (6) in female coupling (2) and hold in place.
- (6) Pull both locking arms (1) back at the same time until arms are down against body of female coupling (2).
- (7) Verify that male coupling (6) and female coupling (2) are connected by pulling on couplings. Couplings should remain securely connected and locking arms (1) must remain snug against coupling body.

DISCONNECTION.**WARNING**

Do not disconnect hose couplings while water system is pressurized. Hose ends may whip, causing injury to personnel and damage to equipment.

- (8) Pull locking arms (1) up and out from female coupling (2).
- (9) Pull female couplings (2) from male couplings (6).
- (10) Insert plug (3) in female coupling (2) and pull locking arms (1) back against coupling body.
- (11) Place cap (5) over male coupling (6) and pull locking arms (4) back against cap body.

d. Install Water Tanks.**NOTE**

A lifting device is required to remove the collapsible fabric tanks from the storage chests and position the tanks at the installation site. Notify unit maintenance to assist you with positioning heavy components.

- (1) Refer to figure 2-8 and place water tanks in position as shown Note position of suction and discharge fittings

NOTE

When collapsible tanks are unfolded, distance between tanks must be maintained to ensure proper clearance for installation of dual tank connection kits.

- (2) Assemble and prepare water tanks for use in accordance with the applicable TM. Reposition tanks as required to maintain correct distance between tanks as shown in figure 2-8.

2-10. ASSEMBLY AND PREPERATION FOR USE -
cont.

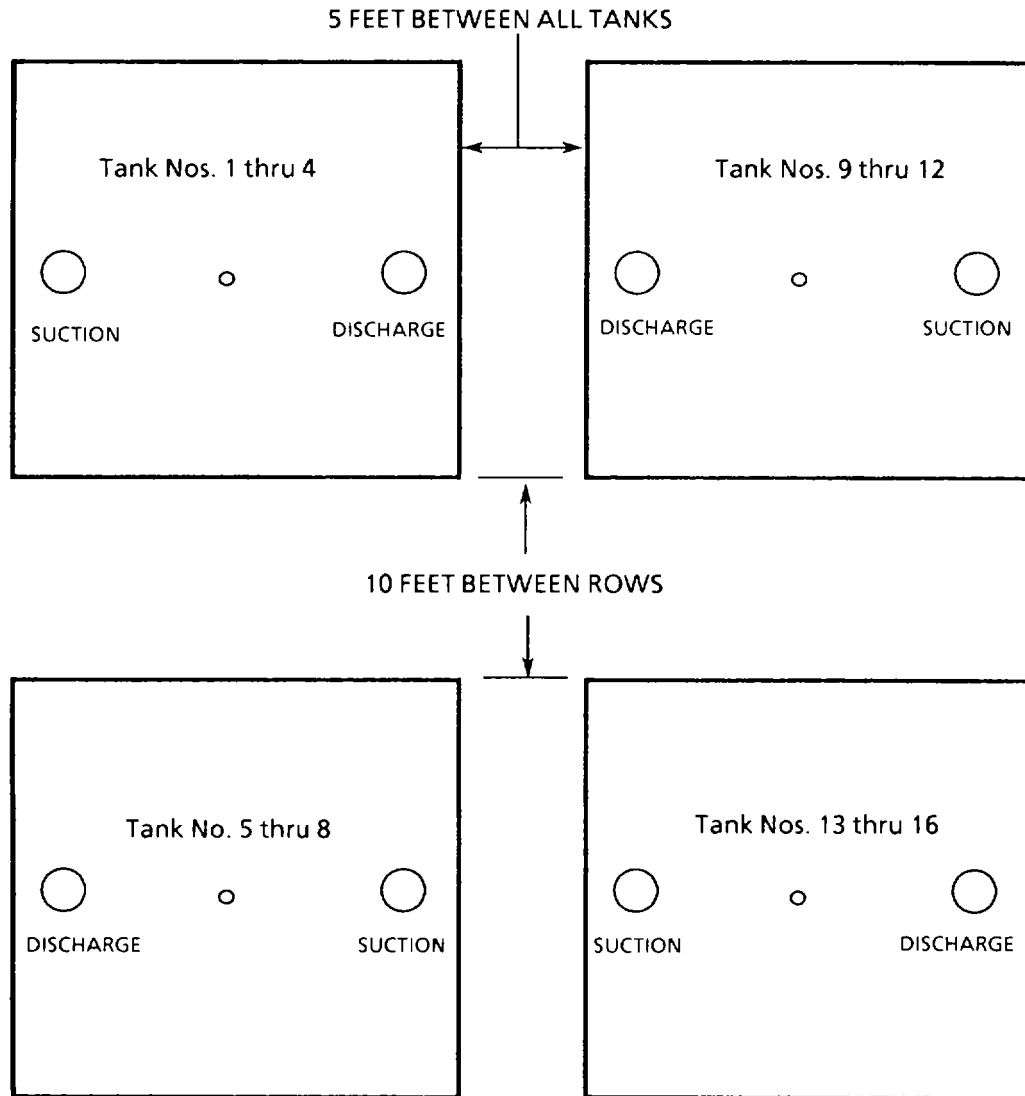
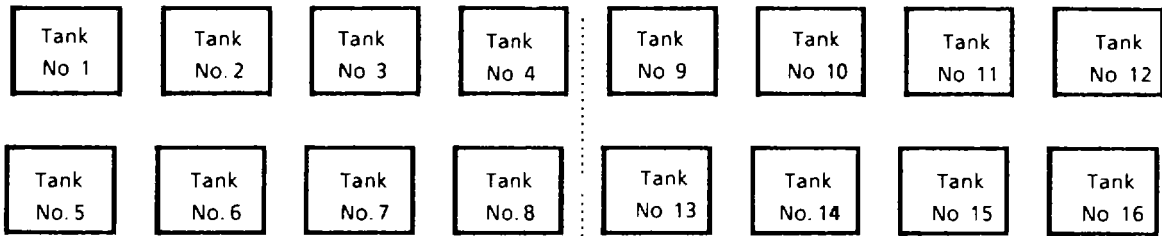

Figure 2-8. Water Tank Positioning.

2-10. ASSEMBLY AND PREPERATION FOR USE - cont.

- e. Assemble Dual Tank Connection Kit Assembly. To aid assembly, each connection kit has been assigned a kit number. Components in kits 5 through 8 are positioned differently (opposite) kits 1 through 4 to allow interconnection of all kits at the 350 gpm pump connection kit tees. Refer to figure 2-9, sheet 1, to assemble kits 1 through 4. Refer to sheet 2 to assemble kits 5 through 8.

WARNING

To prevent contamination of drinking water, make sure water tank elbows are capped and plugged when system hoses are not connected to tank. Do not remove caps and plugs from components until couplings are ready to be connected.

NOTES

- Install all tee and gate valve assemblies with hand wheel in upright position and valve fully closed.
- Adjust spacing between water tanks and reposition connection kit components as needed to prevent kinks or tight bends in hoses.
- Suction hoses are noncollapsible and discharge hoses are collapsible. All couplings in this kit are 4-inches in diameter.

Assemble Kit no., 2, 3, and 4. Refer to figure 2-9, sheet 1.

- (1) Connect 20 foot suction hose (1) to male discharge elbow (2) on water tank (19).
- (2) Connect 20 foot suction hose (3) to male discharge elbow (4) on water tank (20).
- (3) Connect tee and gate valve assembly (5) to suction hose (1).
- (4) Connect tee and gate valve assembly (6) to suction hose (3).
- (5) Connect 20 foot suction hose (7) between tee and gate valve assemblies (5 and 6).
- (6) Connect 10 foot suction hose (8) to tee and gate valve assembly (5).
- (7) Connect 20 foot discharge hose (9) to female discharge elbow (10) on water tank (20).
- (8) Connect tee and gate valve assembly (11) to discharge hose (9).
- (9) Connect 20 foot discharge hose (12) and 10 foot discharge hose (13) to tee and gate valve assembly (11).
- (10) Connect 20 foot discharge hose (14) to female discharge elbow (15) on water tank (19).
- (11) Connect tee and gate valve assembly (16) to discharge hose (14).
- (12) Connect 20 foot discharge hose (17) and 10 foot discharge hose (18) to tee and gate valve assembly (16).

Assemble Kit No. 5, 6, 7, and 8 Refer to figure 2-9, sheet 2.

- (13) Repeat steps (1) through (12) to assemble Kit No. 5, 6, 7, and 8.

2-10. ASSEMBLY AND PREPARATION FOR USE - cont.

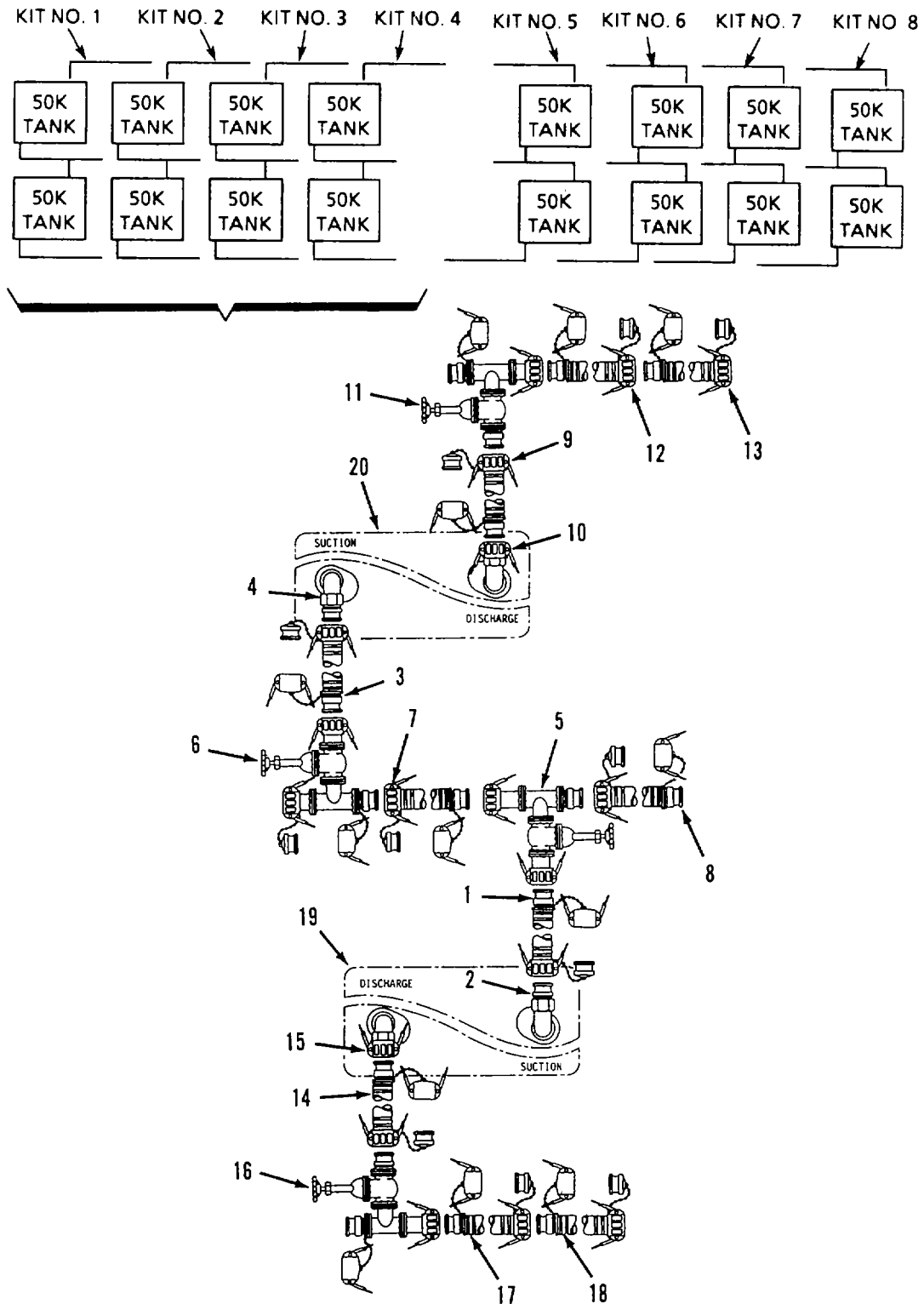

Figure 2-9. Dual Tank Connection Kit Assembly (sheet 1 of 2)

2-10. ASSEMBLY AND PREPARATION FOR USE - cont.

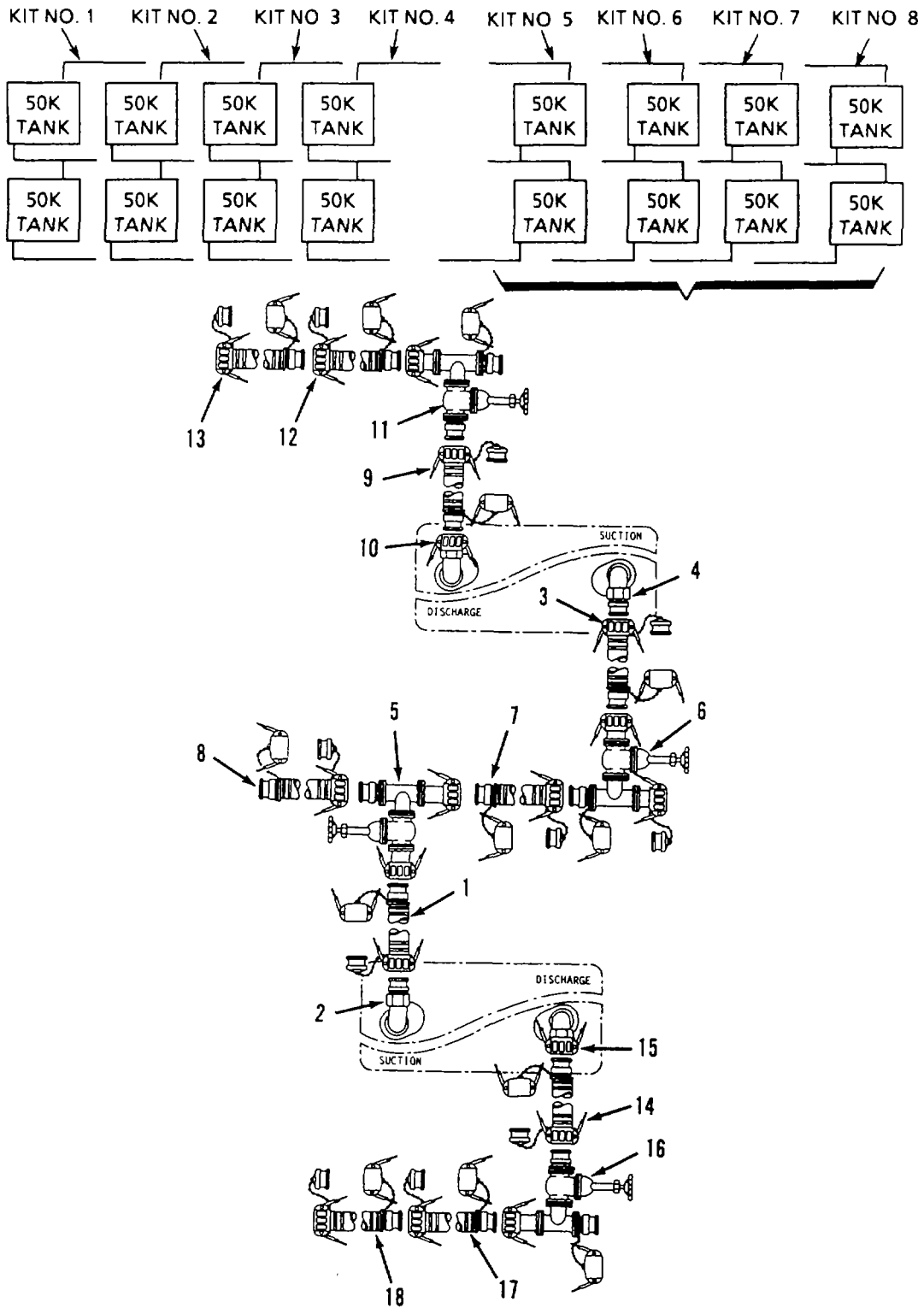

Figure 2-9. Dual Tank Connection Kit Assembly (sheet 2 of 2)

2-10 ASSEMBLY AND PREPERATION FOR USE - cont.

f. Connect Dual Tank Connection Kits. Following assembly of the interconnection kits, the dual tank connection kits must be connected together.

Connect Kit No. 1 to Kit No .2. Refer to figure 2-10.

- (1) Connect 10 foot discharge hose (1) from Kit No.1 to tee and gate valve assembly (2).
- (2) Connect 10 foot suction hose (3) from Kit No.1 to tee and gate valve assembly (4).
- (3) Connect 10 foot discharge hose (5) from Kit No.1 to tee and gate valve assembly (6).
- (4) Install cap (7) on tee and gate valve assembly (8).
- (5) Install plug (9) on tee and gate valve assembly (10).
- (6) Install cap (11) on tee and gate valve assembly (12).

Connect Kit No. 2 to Kit No.3.Refer to figure 2-11

- (7) Connect 10 foot discharge hose (1) to tee and gate valve assembly (2).
- (8) Connect 10 foot suction hose (3) to tee and gate valve assembly (4).
- (9) Connect 10 foot discharge hose (5) to tee and gate valve assembly (6).

Connect Kit No. 3 to Kit No.4.Refer to figure 2-11.

- (10) Repeat steps (7), (8), and (9) to connect Kit No. 3 to Kit No. 4.

2-10. ASSEMBLY AND PREPERATION FOR USE - cont.

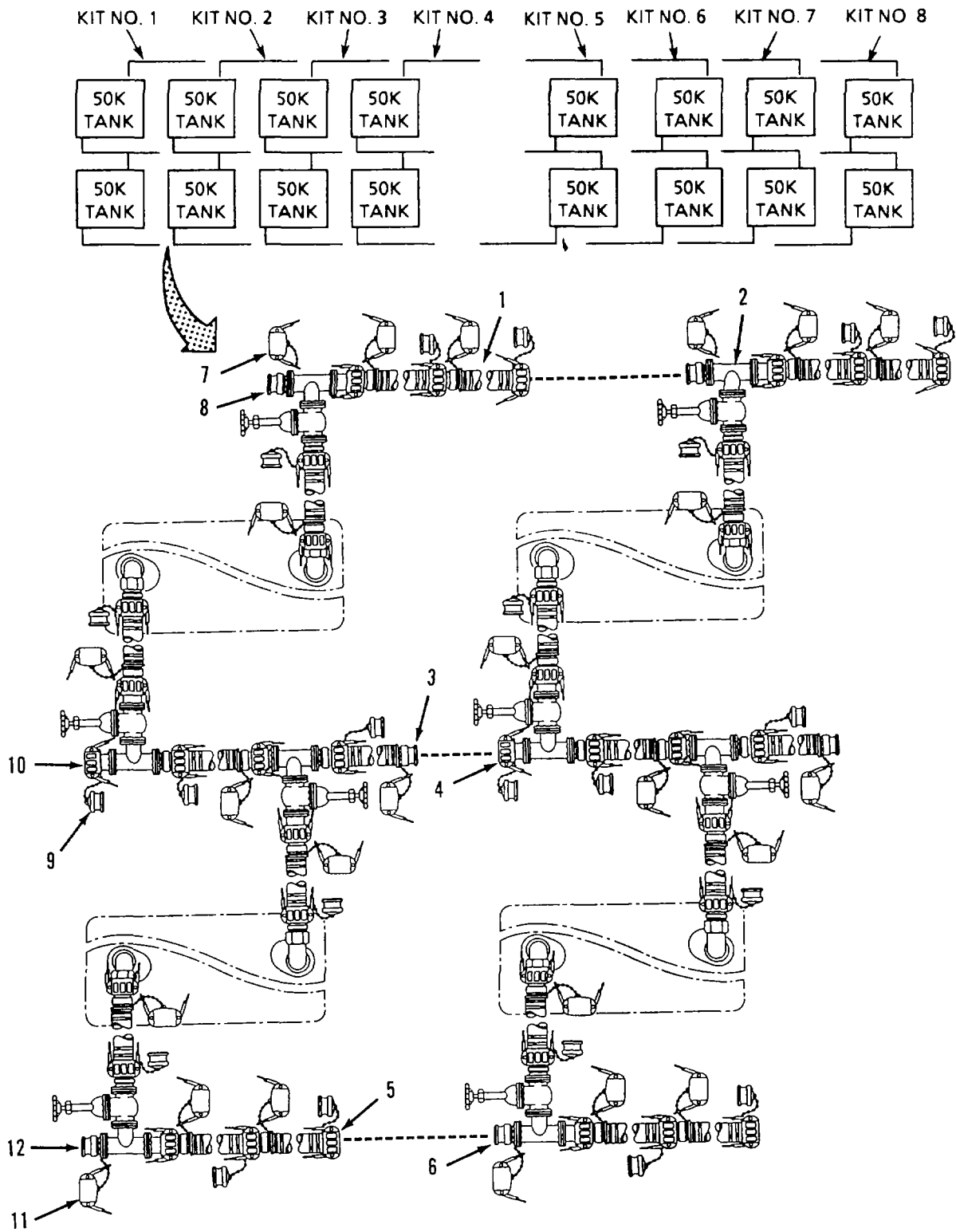

Figure 2-10. Connect Kit No.1 to Kit No.2

2- 10. ASSEMBLY AND PREPARATION FOR USE -
cont.

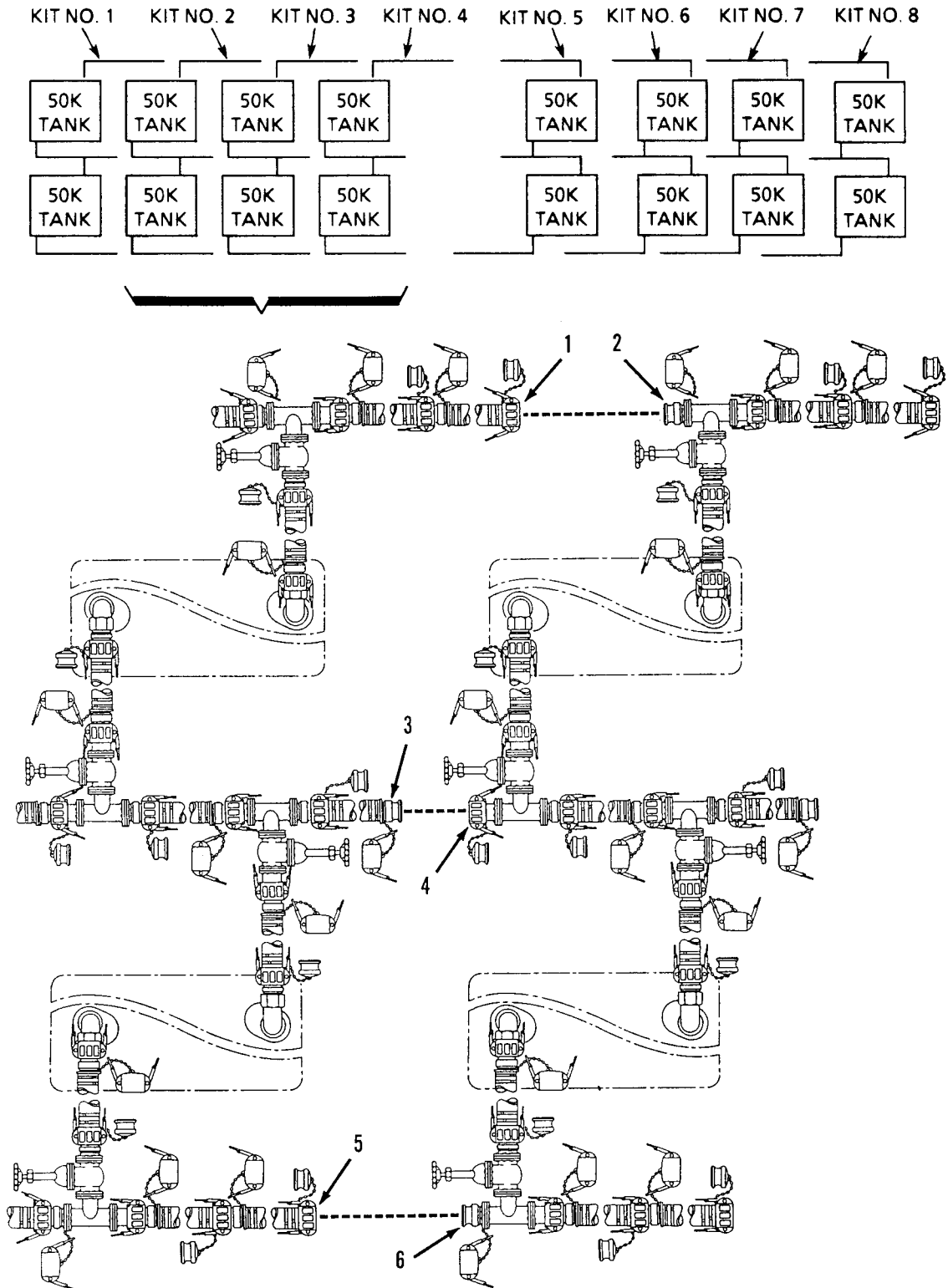

Figure 2-11. Connection Kits 2, 3 and 4.

**2-10. ASSEMBLY AND PREPARATION FOR USE -
cont.**

Connect Kit No.5 to Kit No.6.Refer to figure 2-12.

- (11) Connect 10 foot discharge hose (1) to tee and gate valve assembly (2).
- (12) Connect 10 foot suction hose (3) to tee and gate valve assembly (4).
- (13) Connect 10 foot discharge hose (5) to tee and gate valve assembly (6)

.Connect Kit No.6 to Kit No.7 Refer to figure 2-12.

- (14) Repeat steps (11), (12), and (13) to connect Kit No. 6 to Kit No.7.Connect Kit No.7 to Kit No.8.Refer to figure 2-13.
- (15) Connect 10 foot discharge hose (1) to tee and gate valve assembly (2).
- (16) Connect 10 foot suction hose (3) to tee and gate valve assembly (4).
- (17) Connect 10 foot discharge hose (5) to tee and gate valve assembly (6).
- (18) Install cap (7) on tee and gate valve assembly (8).
- (19) Install plug (9) in tee and gate valve assembly (10).
- (20) Cap (11) on tee and gate valve assembly (12).

2-10 ASSEMBLY AND PREPERATION FOR USE cont.

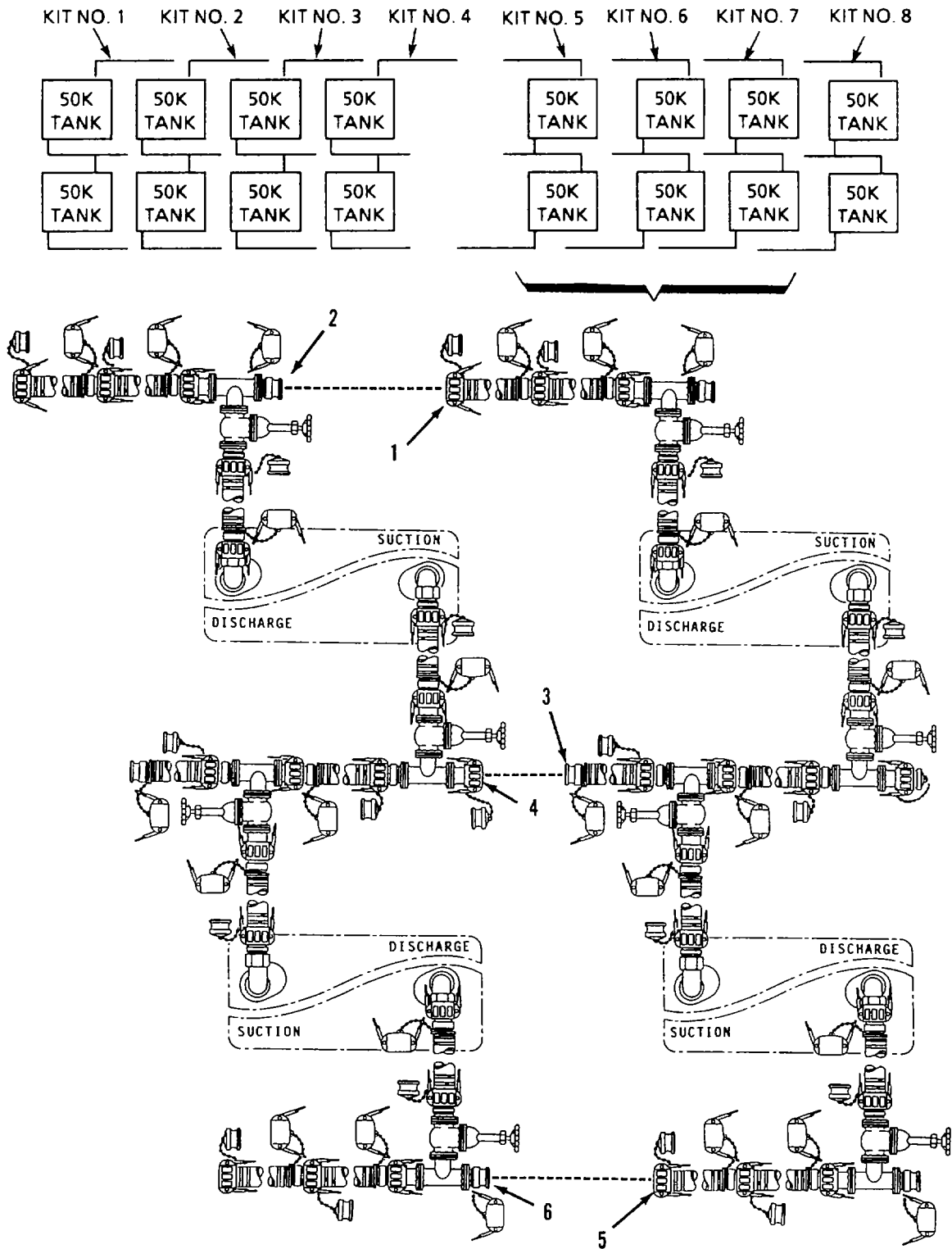

Figure 2-12. Connection Kits 5, 6, and 7.

2-10. ASSEMBLY AND PREPERATION FOR USE - cont.

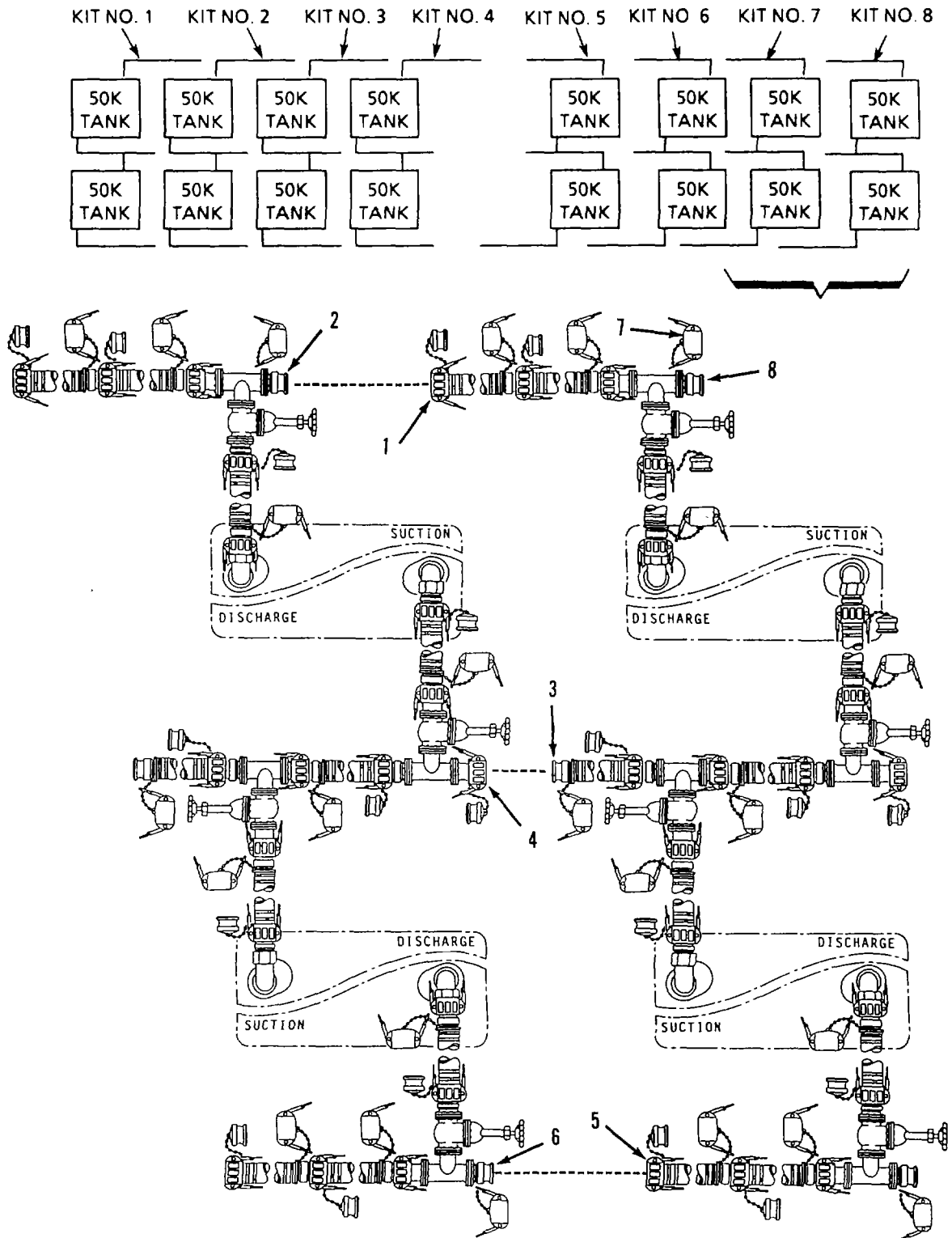

Figure 2-13. Connect Kit 7 to Kit 8.

2-10. ASSEMBLY AND PREPERATION FOR USE - cont.

g. Assemble Interconnection Kits. Two interconnection kits are supplied with the water system. One kit is installed between dual tank connection kits 2 and 3 and the other between kits 6 and 7.

WARNING

To prevent contamination of drinking water, do not remove caps and plugs from components until couplings are ready to be connected.

NOTE

- Each interconnection kit is supplied with ten, 20 foot discharge hoses. This manual reflects a typical water system installation. Install the number of hoses required to meet your installation requirements.
- All couplings in the interconnection kit are 4-inch diameter.

Assemble interconnection kit between dual tank connection kits 2 and 3. Refer to figure 2 -14, sheet 1.

- (1) Disconnect 10 foot discharge hose (2) from 20 foot discharge hose (1).
- (2) Connect tee (3) to 20 foot discharge hose (1).
- (3) Connect 10 foot discharge hose (2) to tee (3).
- (4) Connect four 20 foot discharge hoses (4, 5, 6, and 7) to tee (3).
- (6) Disconnect 10 foot discharge hose (10) from 20 foot discharge hose (9).
- (7) Connect tee (8) to 20 foot discharge hose(9).
- (8) Connect end of 10 foot discharge hose (10) to tee (8).
- (9) Connect end of 20 foot discharge hose (9) to tee (8).

Assemble interconnection kit between dual tank connection kits 6 and 7 Refer to figure 2-14, sheet 2.

- (10) Repeat steps (1) through (9) for other interconnection kit.

2-10. ASSEMBLY AND PREPARATION FOR USE - cont.

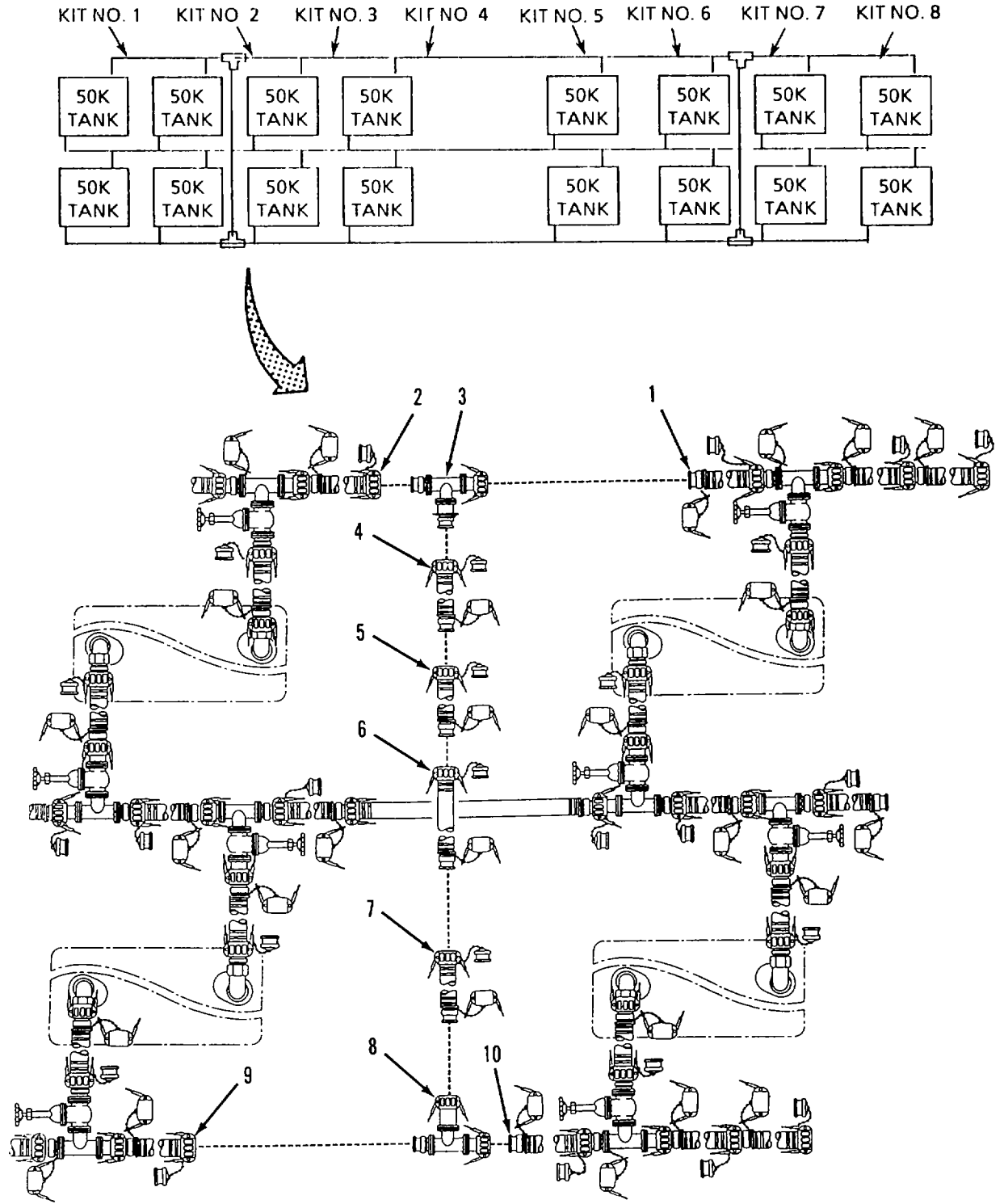

Figure 2-14. Interconnection Kit Assembly (Sheet I of 2).

2-10.ASSEMBLY AND PREPARATION FOR USE - cont.

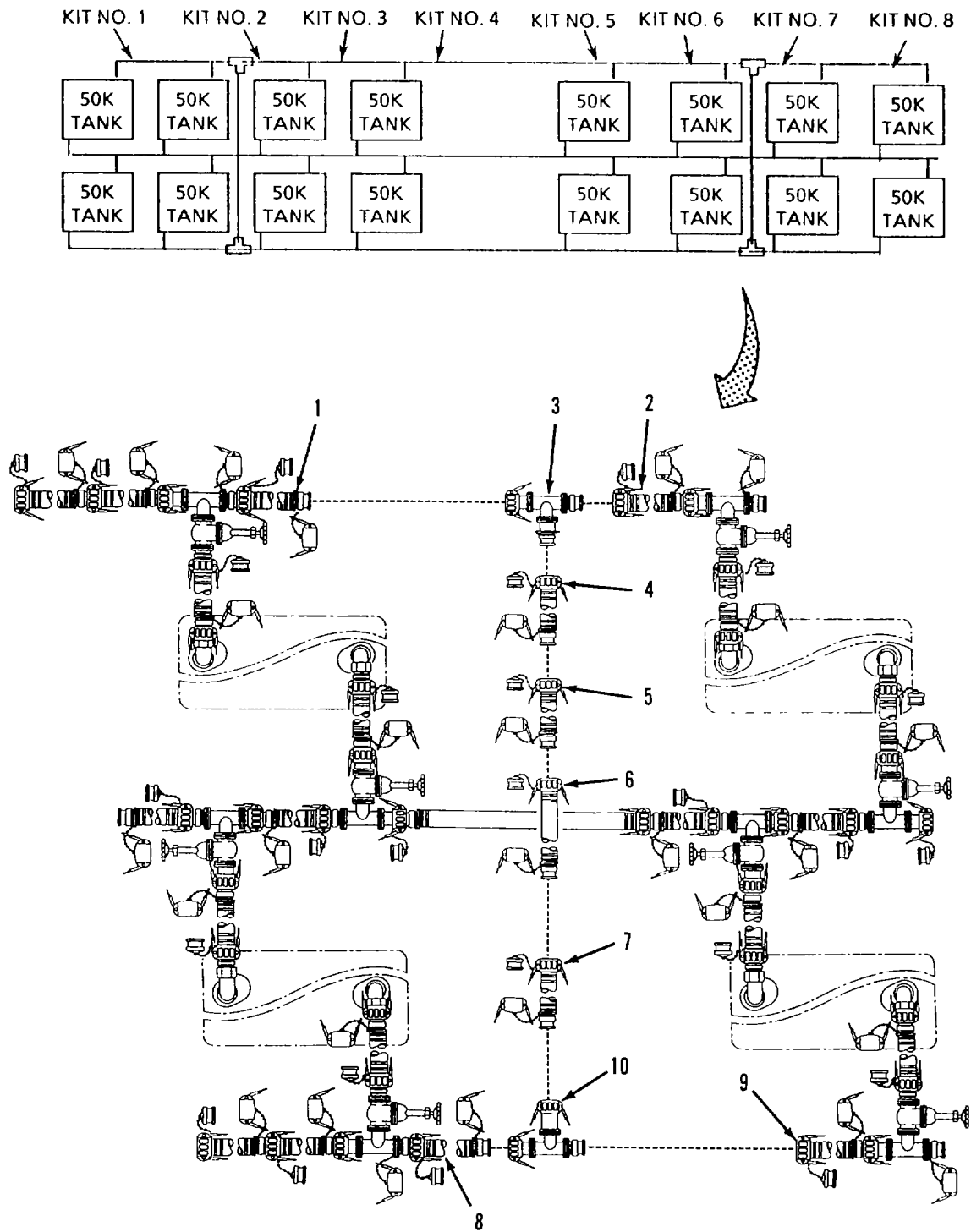

Figure 2-14. Interconnection Kit Assembly (sheet 2 of 2).

2-10. ASSEMBLY AND PREPARATION FOR USE - Cont

- h. Assemble 350 Gpm Pump Connection Kit (Water Source). Refer to figure 2-15.

WARNING

To prevent contamination of drinking water, make sure protective caps and plugs are installed when components are not in use. Do not remove caps and plugs from components until couplings are ready to be connected.

NOTES

- Install all gate valves with hand wheel in upright position and valve fully closed.
 - Suction hoses are noncollapsible and discharge hoses are collapsible.
 - All components in this kit are 4-inch diameter.
- (1) Connect 10 foot discharge hose (3) from connection kit 4 to tee (1).
 - (2) Connect 10 foot discharge hose (2) from connection kit 5 to tee (1).
 - (3) Connect water meter (4) to tee (1).
 - (4) Connect 20 foot discharge hose (5) to water meter (4).
 - (5) Assemble and prepare hypochlorination unit for use. Refer to the applicable TM.
 - (6) Position hypochlorination unit (6) in water system.
 - (7) Connect 20 foot discharge hose (5) to male (outlet) coupling on hypochlorination unit (6).
 - (8) Connect 20 foot discharge hose (7) to female (inlet) coupling on hypochlorination unit (6).
 - (9) Connect tee (8) to 20 foot discharge hose (7).
 - (10) Connect 20 foot discharge hose (9) to tee (8).
 - (11) Connect 4-inch gate (10) to 20 foot discharge hose (9).
 - (12) Connect 20 foot discharge hose(11) to 4-inch gate valve (10).
 - (13) Assemble and prepare 350 gpm pump (12) for use. Refer to the applicable TM.
 - (14) Position 350 gpm pump (12) in water system.
 - (15) Connect end of 20 foot discharge hose (11) to male (discharge) coupling on 350 gpm pulp (12).

2-10. ASSEMBLY AND PREPARATION FOR USE - Cont

- (16) Connect 20 foot suction hose (13) to female (suction) coupling on 350 gpm pump (12).
- (17) Connect 4-inch gate valve (14) to 20 foot suction hose (13).
- (18) Connect tee (15) to 4-inch gate valve (14).
- (19) Connect 20 foot suction hose (16) to tee (15).
- (20) Connect tee (17) to 20 foot suction hose (16).
- (21) Connect tee (17) to water source.

2-10. ASSEMBLY AND PREPARATION FOR USE-Cont.

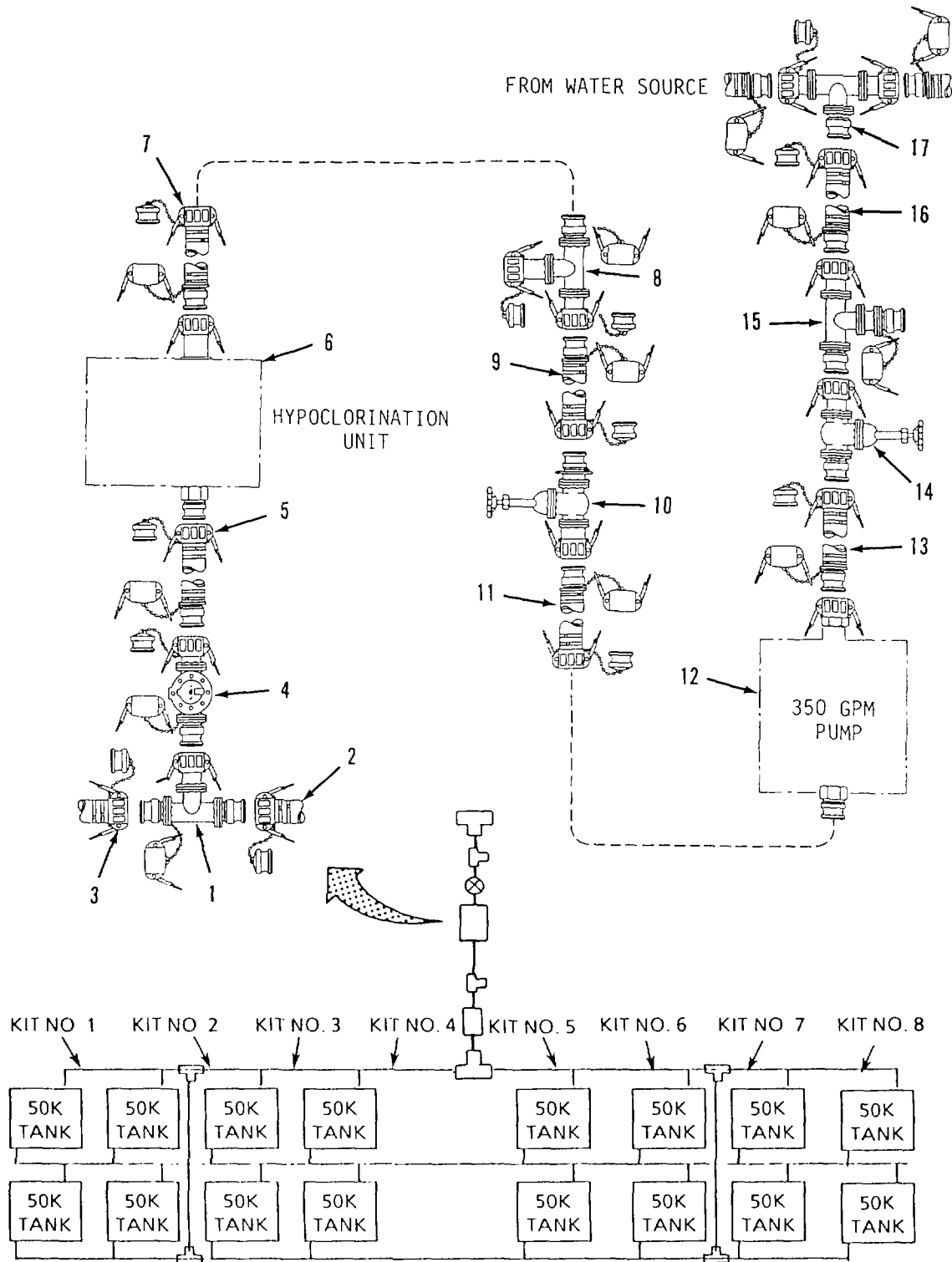

Figure 2-15. 350 Gpm Pump Connection Kit Assembly (Water Source).

2-10. ASSEMBLY AND PREPARATION FOR USE - cont.

- i. Assemble 125 GPM Pump Assembly Connection Kit (Water Source). Refer to figure 2-16.

WARNING

To prevent contamination of drinking water, make sure protective caps and plugs are installed when components are not in use. Do not remove caps and plugs from components until couplings are ready to be connected.

NOTES

- Install all gate valves with hand wheel in upright position and valve fully closed.
 - Suction hoses are noncollapsible and discharge hoses are collapsible.
 - With exception of two adapters, all couplings in this kit are 2-inch diameter.
- (1) Connect adapter- (4-inch female x 2-inch male) (2) to tee (1) from 350 gpm pump connection kit.
 - (2) Connect 20 foot suction hose (3) to adapter (2).
 - (3) Connect 2-inch gate valve (4) to 20 foot suction hose (3).
 - (4) Connect 20 foot suction hose (5) to 2-inch gate valve (4).
 - (5) Assemble and prepare 125 gpm pump (6) for use. Refer to the applicable TM.
 - (5) Position 125 gpm pump (6) in water system.
 - (7) Connect end of 20 foot suction hose (5) to female (suction) coupling (7) on pump (6).
 - (8) Connect 20 foot discharge hose (9) to male (discharge) coupling (8) on 125 gpm pump (6).
 - (9) Connect check valve (10) to 20 foot discharge hose (9).
 - (10) Connect 2-inch gate valve (11) to check valve (10).
 - (11) Connect 20 foot discharge hose (12) to 2-inch gate valve (11).
 - (12) Connect adapter (4-inch male x 2-inch female) (13) to tee (14) from 350 gpm pump connection kit.
 - (13) Connect end of 20 foot discharge hose (12) to adapter (13).

2-10. ASSEMBLY AND PREPARATION FOR USE-Cont.

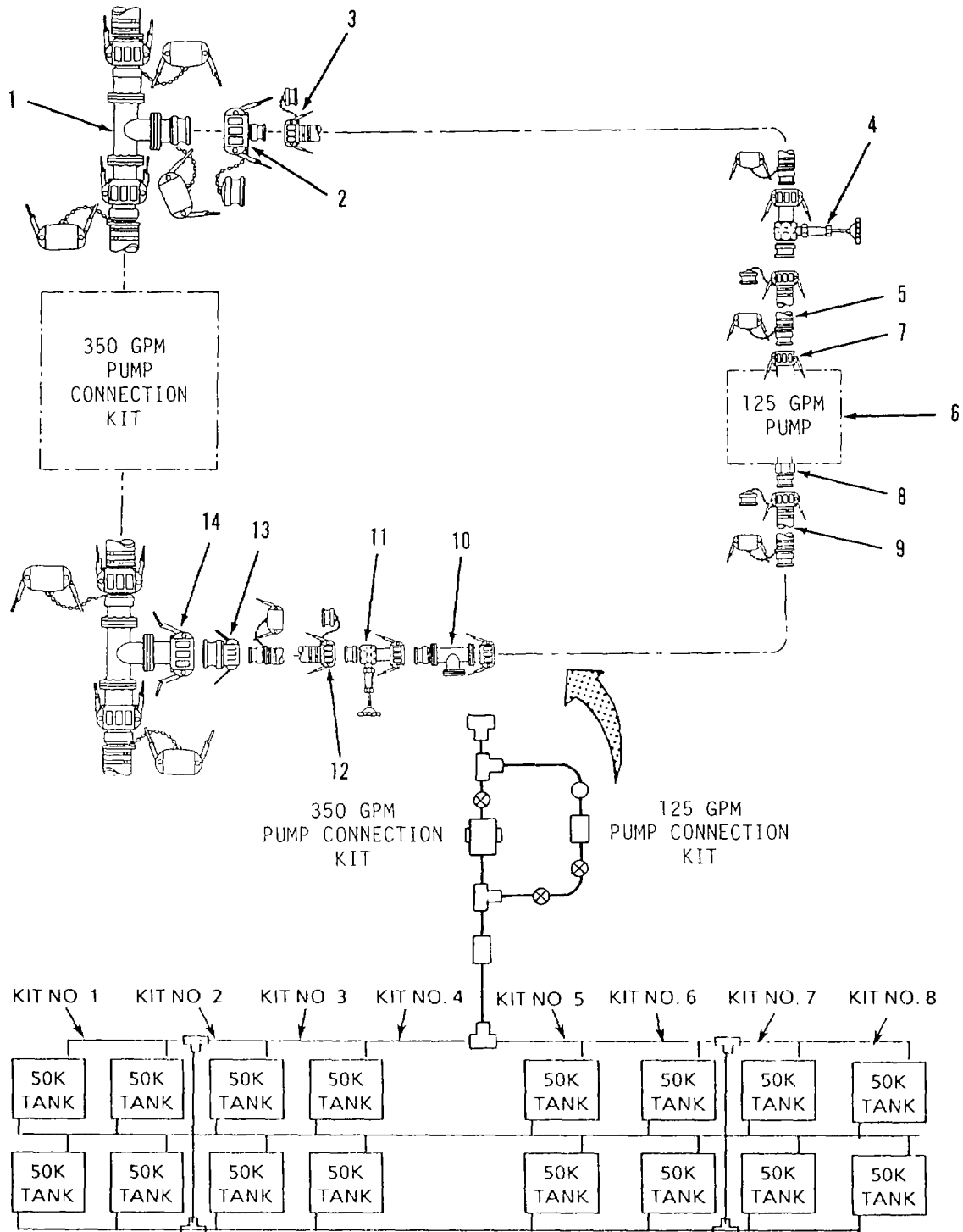

Figure 2-16. 125 Gpm Pump Connection Kit Assembly (Water Source).

2-10. ASSEMBLY AND PREPARATION FOR USE - cont.

- j. Assemble 350 Gpm Pump Connection Kit (Distribution Point). Refer to figure 2-17.

WARNING

To prevent contamination of drinking water, make sure protective caps and plugs are installed when components are not in use. Do not remove caps and plugs from components until couplings are ready to be connected.

NOTES

- Install all gate valves with hand wheel in upright position and valve fully closed.
 - Suction hoses are noncollapsible and discharge hoses are collapsible.
 - All components in this kit are 4-inch diameter.
- (1) Connect tee (1) to 10 foot discharge hose (2) (part of connection kit 4).
 - (2) Connect 10 foot discharge hose (3) (part of dual tank connection kit no.5) to tee (1).
 - (3) Connect 20 foot suction hose (4) to tee (1).
 - (4) Connect tee (5) to 20 foot suction hose (4).
 - (5) Connect 4-inch gate valve (6) to tee (5).
 - (6) Connect 20 foot suction hose (7) to 4-inch gate valve (6).
 - (7) Assemble, prepare for use and position 350 gpm pump (8) in water system. Refer to the applicable TM.
 - (8) Connect 20 foot suction hose (7) to female (suction) coupling on 350 gpm pump (8).
 - (9) Connect of 20 foot discharge hose (9) to male (discharge) coupling on 350 gpm pump (8).
 - (10) Connect 4-inch gate valve (10) to 20 foot discharge hose (9).
 - (11) Connect 20 foot discharge hose (11) to 4-inch gate valve (10).
 - (12) Connect tee (12) to 20 foot discharge hose (11).
 - (13) Connect 20 foot discharge hose (13) to tee (12).
 - (14) Assemble, prepare for use, and position hypochlorination unit (14) in water system. Refer to the applicable TM.
 - (15) Connect end of 20 foot discharge hose (13) to female (inlet) coupling on hypochlorination unit (14).
 - (16) Connect 20 foot discharge hose (15) to male (outlet) coupling on hypochlorination unit (14).

2-10. ASSEMBLY AND PREPARATION FOR USE - cont.

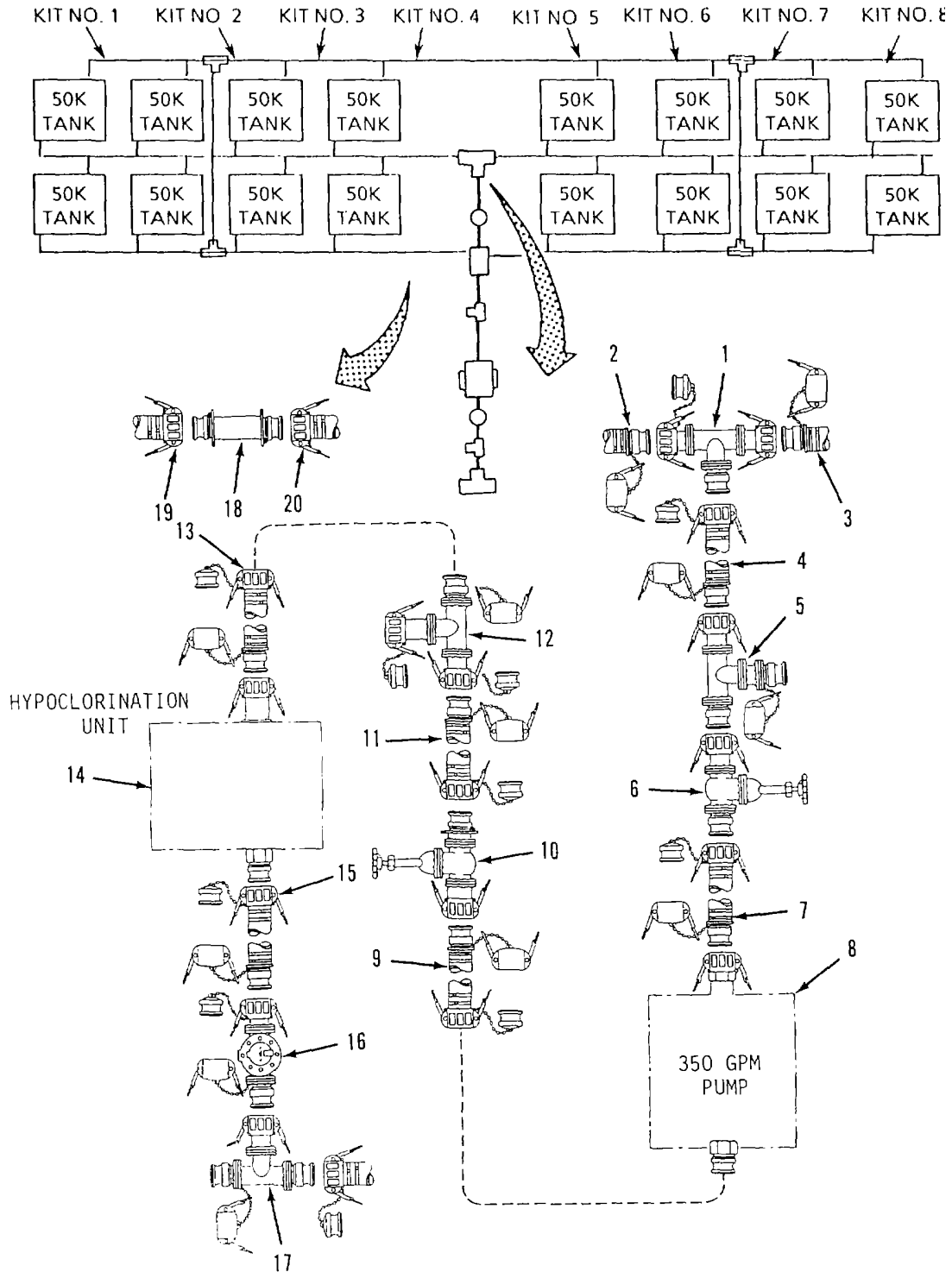

Figure 2-17. 350 Gpm Pump Connection Kit Assembly (Distribution Point).

2-10. ASSEMBLY AND PREPARATION FOR USE - cont.

- (17) Connect water meter (16) to 20 foot discharge hose (15).
- (18) Connect tee (17) to water meter (16).
- (19) Connect adapter (4-inch male x 4-inch male) (18) to 10 foot discharge hose (19) (part of dual tank connection kit no. 4)
- (20) Connect 10 foot discharge hose (20) (part of dual tank connection kit no 5) to adapter (18).

k. Assemble 125 Gpm Pump Connection Kit (Distribution Point). Refer to figure 2-18.

WARNING

To prevent contamination of drinking water, make sure protective caps and plugs are installed when components are not in use. Do not remove caps and plugs from components until couplings are ready to be connected.

NOTES

- Install all gate valves with hand wheel in upright position and valve fully closed.
 - Suction hoses are noncollapsible and discharge hoses are collapsible.
 - With exception of two adapters, all couplings in this kit are 2-inch diameter.
- (1) Connect adapter (4-inch female x 2-inch male) (2) to tee (1) (part of 350 gpm pump connection kit).
 - (2) Connect 20 foot suction hose (3) to adapter (2).
 - (3) Connect 2-inch gate valve (4) to 20 foot suction hose (3).
 - (4) Connect 20 foot suction hose (5) to 2-inch gate valve (4).
 - (5) Assemble, prepare for use, and position 125 gpm pump (6) in water system. Refer to the applicable TM.
 - (6) Connect end of 20 foot suction hose (5) to female (suction) coupling (7) on 125 gpm pump (6).
 - (7) Connect 20 foot discharge hose (9) to male (discharge) coupling (8) on 125 gpm pump (6). Refer to the applicable TM.
 - (8) Connect check valve (10) to 20 foot discharge hose (9).
 - (9) Connect 2-inch gate valve (11) to check valve (10).
 - (10) Connect 20 foot discharge hose (12) to 2-inch gate valve (11).
 - (11) Connect adapter (4-inch male x 2-inch female) (13) to tee (14) (part of 350 gpm pump connection kit).

2-10. ASSEMBLY AND PREPARATION FOR USE - cont.

(12) Connect end of 20 foot discharge hose (12) to adapter (13).

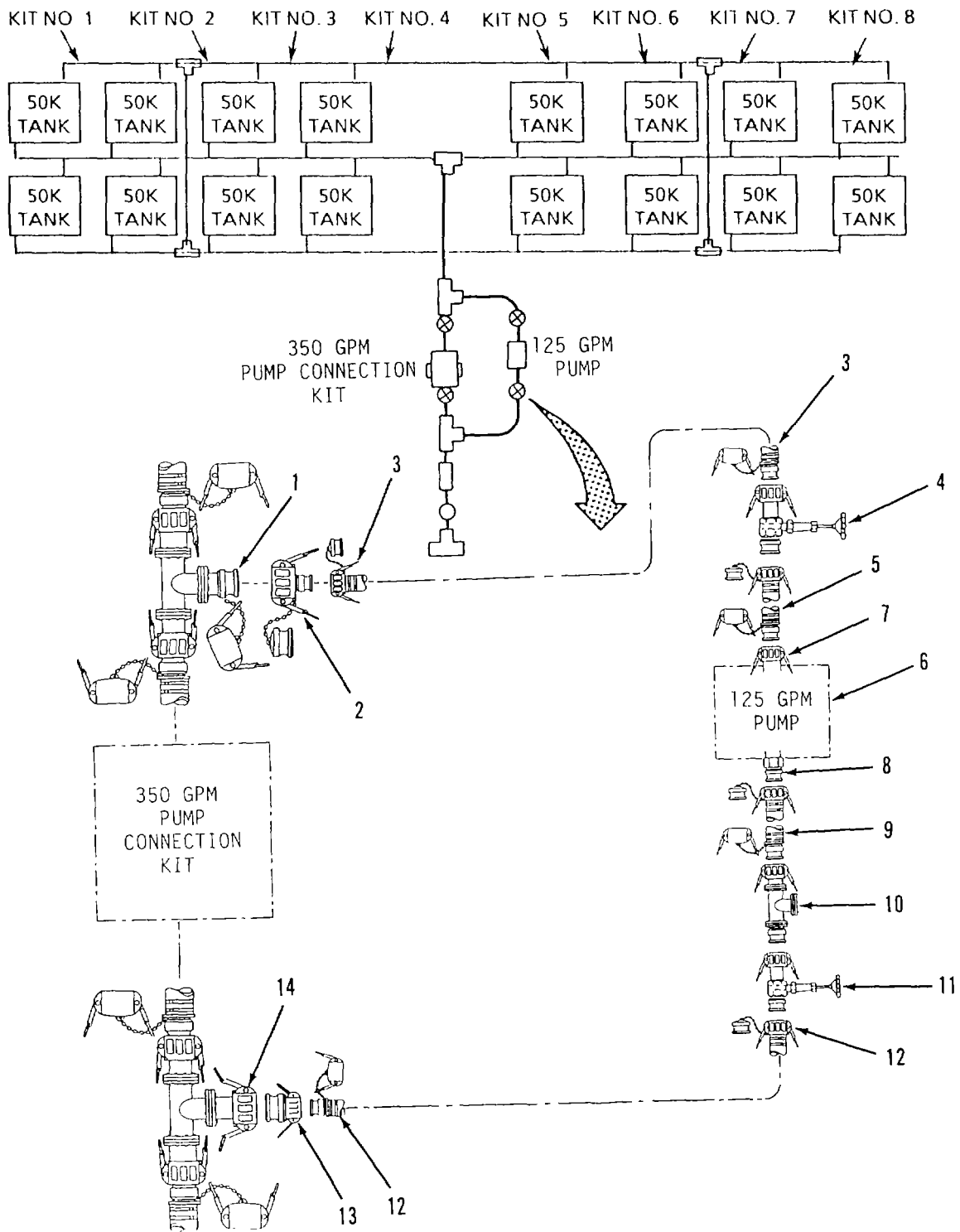

Figure 2-18. 125 Gpm Pump Connection Kit Assembly (Distribution Point).

2-10. ASSEMBLY AND PREPARATION FOR USE - cont.

- I. Assemble 2-Inch Hose Connection Kits. Refer to figure 2-19.

WARNING

To prevent contamination of drinking water, make sure protective caps and plugs are installed when components are not in use. Do not remove caps and plugs from components until couplings are ready to be connected.

NOTE

- Install all gate valves with hand wheel in upright position and valve fully closed.
- Six 2-inch hose connection kits are used in the water system. Kits 1, 2 and 3 are a mirror image of kits 4, 5 and 6.

2-Inch Hose Connection Kits No. 1, 2 and 3.

- (1) Connect 4 inch x 20 foot discharge hose (1) to tee (8) from 350 gpm pump connection kit.
- (2) Connect 4 inch x 20 foot discharge hose (2) to 4 inch x 20 foot discharge hose (1).
- (3) Connect tee (3) to 4 inch x 20 foot discharge hose (2).
- (4) Connect adapter (4-inch female x 2-inch male) (4) to tee (3).
- (5) Connect 2-inch gate valve (5) to adapter (4).
- (6) Connect 2 inch x 20 foot discharge hose (6) to 2-inch gate valve (5).
- (7) Unfold nozzle stand assembly (7) and attach discharge hose (6) to bracket on stand.
- (8) Connect 4-inch x 20 foot discharge hose (1) to tee (3) from previous kit.
- (9) Repeat steps 2 through 8 for hose connection Kit No. 2 and 3.

2-Inch Hose Connection Kits No. 4, 5 and 6

- (10) Connect 4 inch x 20 foot discharge hose (9) to tee (8) from 350 gpm pump connection kit.
- (11) Connect 4 inch x 20 foot discharge hose (10) to 4 inch x 20 foot discharge hose (9).
- (12) Connect tee (11) to 4 inch x 20 foot discharge hose (10).
- (13) Connect adapter (4-inch female x 2-inch male) (12) to tee (11).
- (14) Connect 2-inch gate valve (13) to adapter (12).
- (15) Connect 2 inch x 20 foot discharge hose (14) to 2-inch gate valve (13).
- (16) Unfold nozzle stand assembly (15) and attach discharge hose (14) to bracket on stand.

2-10. ASSEMBLY AND PREPARATION FOR USE - cont.

- (17) Connect 4-inch x 20 foot discharge hose (9) to tee (1) from previous kit.
- (18) Repeat steps 11 through 17 for hose connection Kit No 5 and 6.

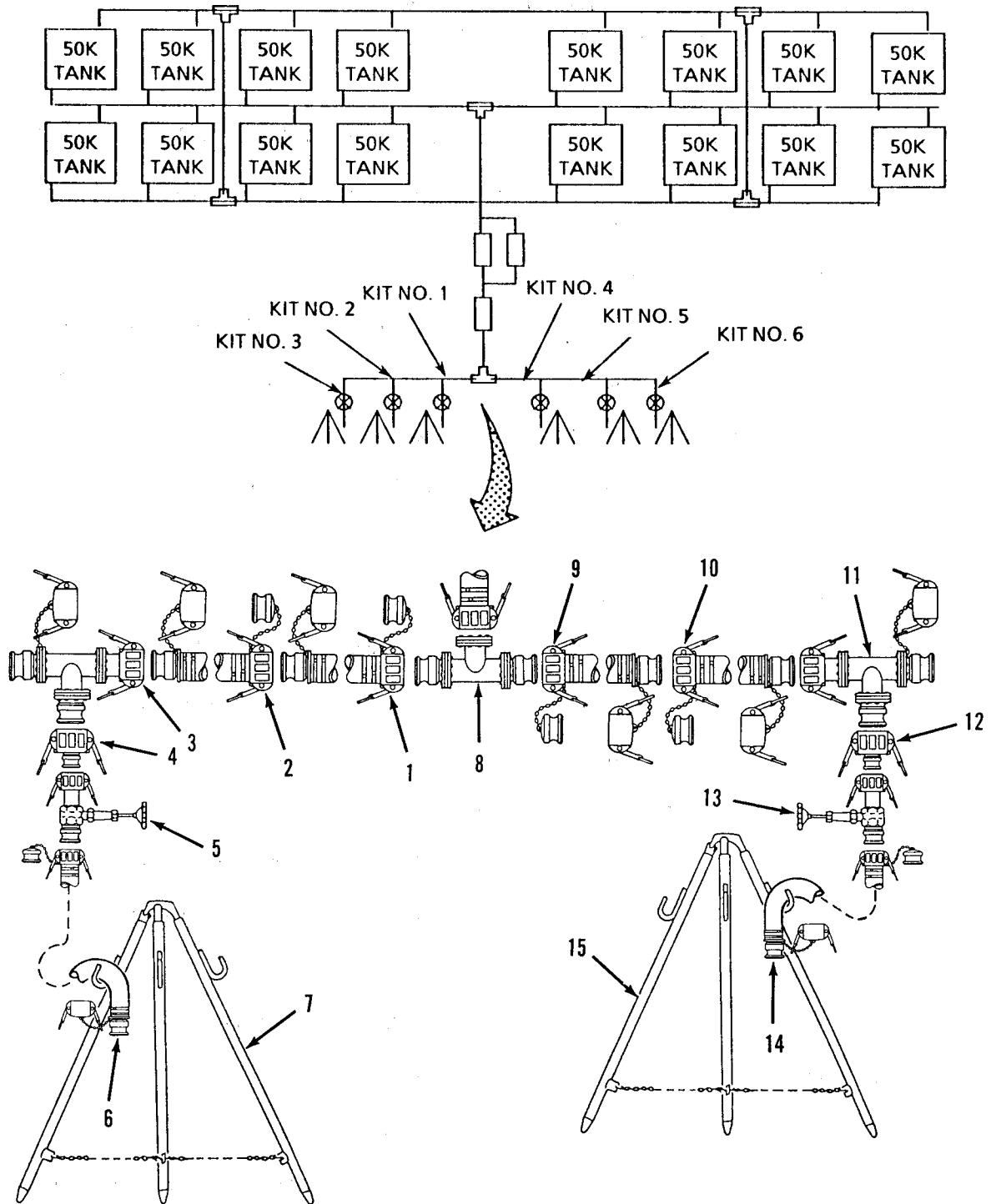

Figure 2-19. 2-Inch Hose Connection Kit Assembly.

2-10. ASSEMBLY AND PREPARATION FOR USE - cont.

- m. Assemble hose Nozzle Connection Kits. Refer to figure 2-20.

WARNING

To prevent contamination of drinking water, make sure protective caps and plugs are installed when components are not in use. Do not remove caps and plugs from components until couplings are ready to be connected.

NOTE

- Install all gate valves with hand wheel in upright position and valve fully closed.
 - Four 2-inch hose nozzle connection kits are used in the water system Connection kit no. 1 is shown, kit no 2, 3, and 4 are similar.
- (1) Connect 4 inch x 20 foot discharge hose (2) to tee assembly (1) (2-inch hose connection kit).
 - (2) Connect 4 inch x 20 foot discharge hose (3) to 4 inch x 20 foot discharge hose (2).
 - (3) Connect tee (4) to 4 inch x 20 foot discharge hose (3).
 - (4) Connect adapter (4 inch female x 2-inch male) (5) to tee (4).
 - (5) Connect 2-inch gate valve (6) to adapter (5).
 - (6) Connect 2 inch x 20 foot discharge hose (7) to gate valve (6).
 - (7) Connect adapter (2 inch female x 1-½ inch male) (8) to 2 inch x 20 foot discharge hose (7).
 - (8) Connect 1-½ inch x 25 foot discharge hose (9) to adapter (8).
 - (9) Connect distribution nozzle (10) to 1-½ inch x 25 foot discharge hose (9).
 - (10) Unfold nozzle stand assembly (11) and attach distribution nozzle (10) to bracket on stand.
 - (11) Repeat steps 1 through 10 for connection Kits 2, 3, and 4.

2-10. ASSEMBLY AND PREPARATION FOR USE - cont.

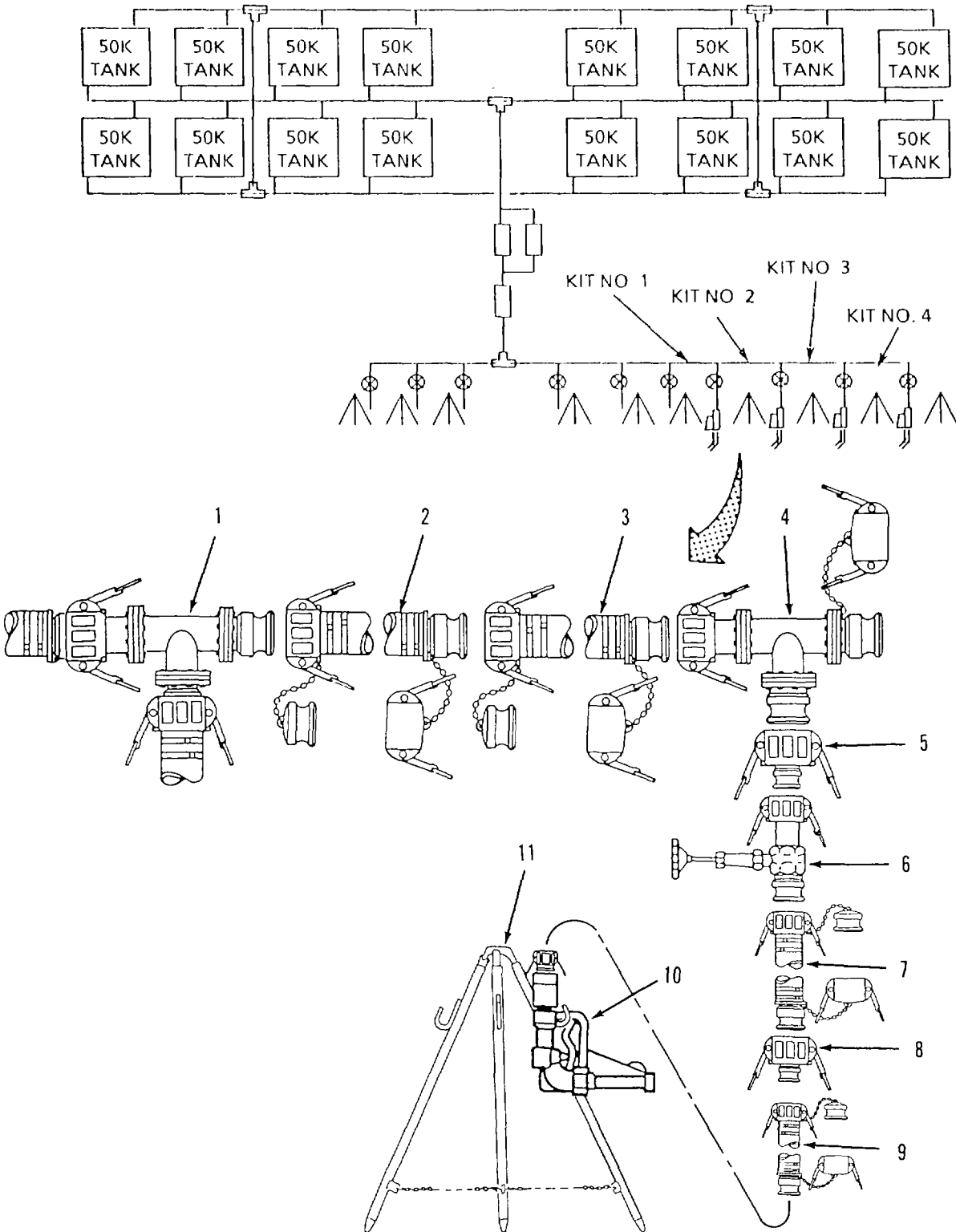

Figure 2-20. Hose Nozzle Connection Kit.

2-10. ASSEMBLY AND PREPARATION FOR USE - cont.

- n. Assemble Bag Filter Connection Kit. Refer to figure 2-21.

WARNING

To prevent contamination of drinking water, make sure protective caps and plugs are installed when components are not in use. Do not remove caps and plugs from components until couplings are ready to be connected.

NOTE

Install all gate valves with hand wheel in upright position and valve fully closed.

- (1) Connect 4 inch x 20 foot discharge hose (2) to tee (1) (from hose nozzle connection kit no. 4).
- (2) Connect 4 inch x 20 foot discharge hose (3) to 4 inch x 20 foot discharge hose (2).
- (3) Connect tee (5) to 4 inch x 20 foot discharge hose (3).
- (4) Connect adapter (4 inch female x 2 inch male (6) to tee (5).
- (5) Connect 2 inch x 20 foot discharge hose (7) to adapter (6).
- (6) Connect wye (8) to 2 inch x 20 foot discharge hose (7).
- (7) Connect 2 inch x 20 foot discharge hose (9) to wye (8).

NOTE

The 2 inch gate valves used in this connection kit have a 2 inch female coupling on one end and a 1-½ inch male coupling on the other.

- (8) Connect 2 inch gate valve (10) to 2 inch x 20 foot discharge hose (9).
- (9) Connect 1-½ inch x 25 foot discharge hose (11) to 2 inch gate valve (10).
- (10) Connect 2 inch x 20 foot discharge hose (12) to wye (8).
- (11) Connect wye (13) to 2 inch x 20 foot discharge hose (12).
- (12) Connect 2 inch gate valve (14) to wye (13).
- (13) Connect 1-½ inch x 25 foot discharge hose (15) to 2 inch gate valve (14).
- (14) Connect 2 inch gate valve (16) to wye (13).
- (15) Connect 1-½ inch x 25 foot discharge hose (17) to 2 inch gate valve (16).
- (16) Install cap (4) on unused male coupling on tee (5).

2-10. ASSEMBLY AND PREPARATION FOR USE - cont.

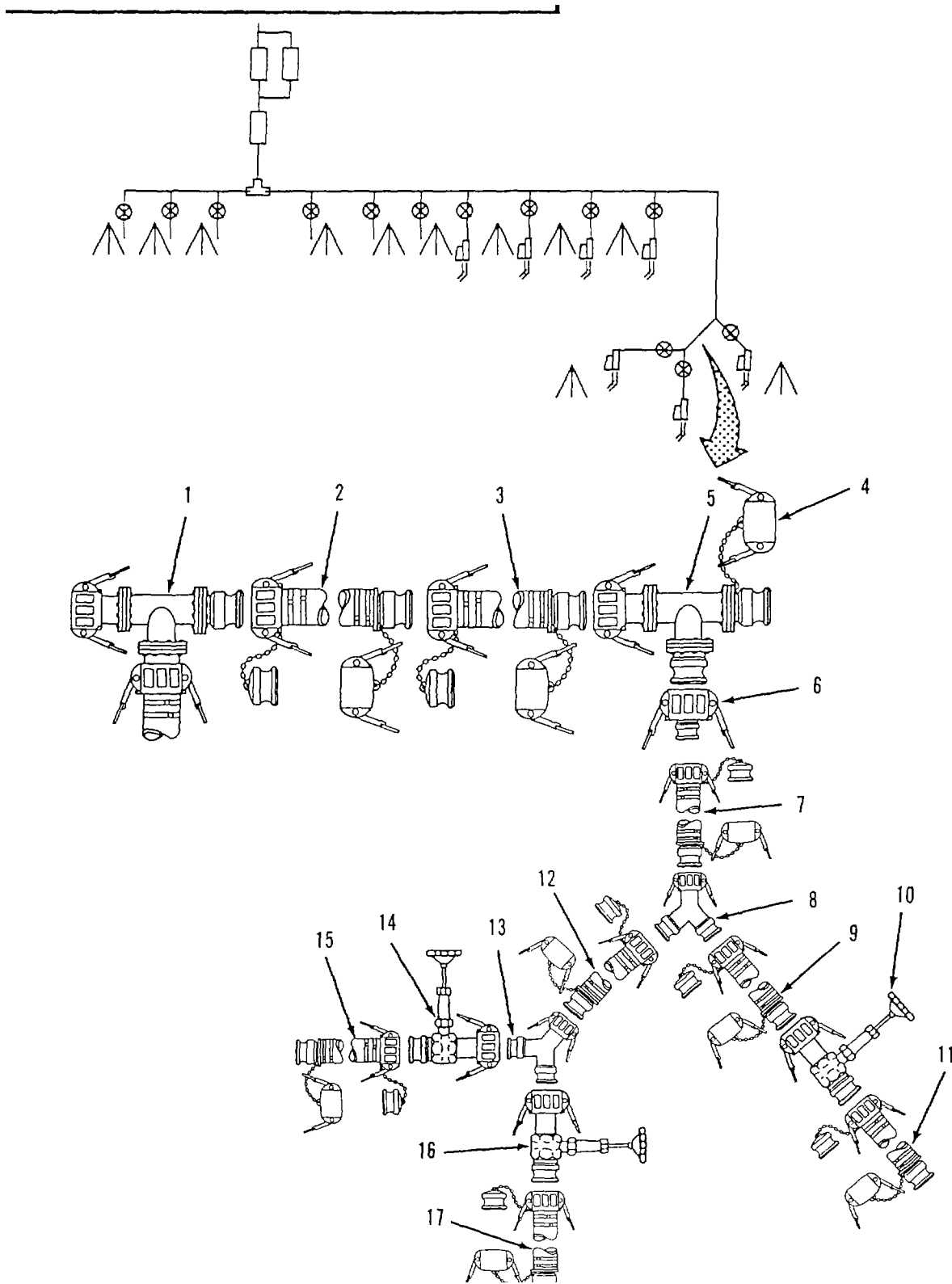

Figure 2-21. Bag Filler Connection Kit Assembly.

2-10. ASSEMBLY AND PREPARATION FOR USE - cont.

- o. Assemble Hose and Nozzle Kits. Refer to figure 2-22.

WARNING

To prevent contamination of drinking water, make sure protective caps and plugs are installed when components are not in use. Do not remove caps and plugs from components until couplings are ready to be connected.

NOTE

- A 2 inch female x 1-½ male adapter is supplied with each hose and nozzle kit for connecting the kits directly to a 2 inch discharge hose. These adapters will not be used in this assembly procedure. Your operating conditions may require use of the adapters
- Three hose and nozzle kits are used in the water system. Kit no 1 is shown, kit no. 2 and 3 are similar.

- (1) Connect adapter (1-½ inch female x 1 inch male) (2) to 1-½ inch x 25 foot discharge hose (1) (from bag filler connection kit).
- (2) Connect two 1 inch x 10 foot discharge hoses (3 and 4) to adapter (2).
- (3) Connect regulator (5) to 1 inch x 10 foot discharge hose (4). Make sure regulator is positioned with wooden base down on ground.
- (4) Connect two 1 inch x 10 foot discharge hoses (6 and 7) regulator (5).
- (5) Connect distribution nozzle (8) to 1 inch x 10 foot discharge hose (7).
- (6) Unfold nozzle stand assembly (9) and attach distribution nozzle (8) to bracket on stand.
- (7) Repeat steps (1) through (6) for kit no 2 and no 3.

2-10. ASSEMBLY AND PREPARATION FOR USE - cont.

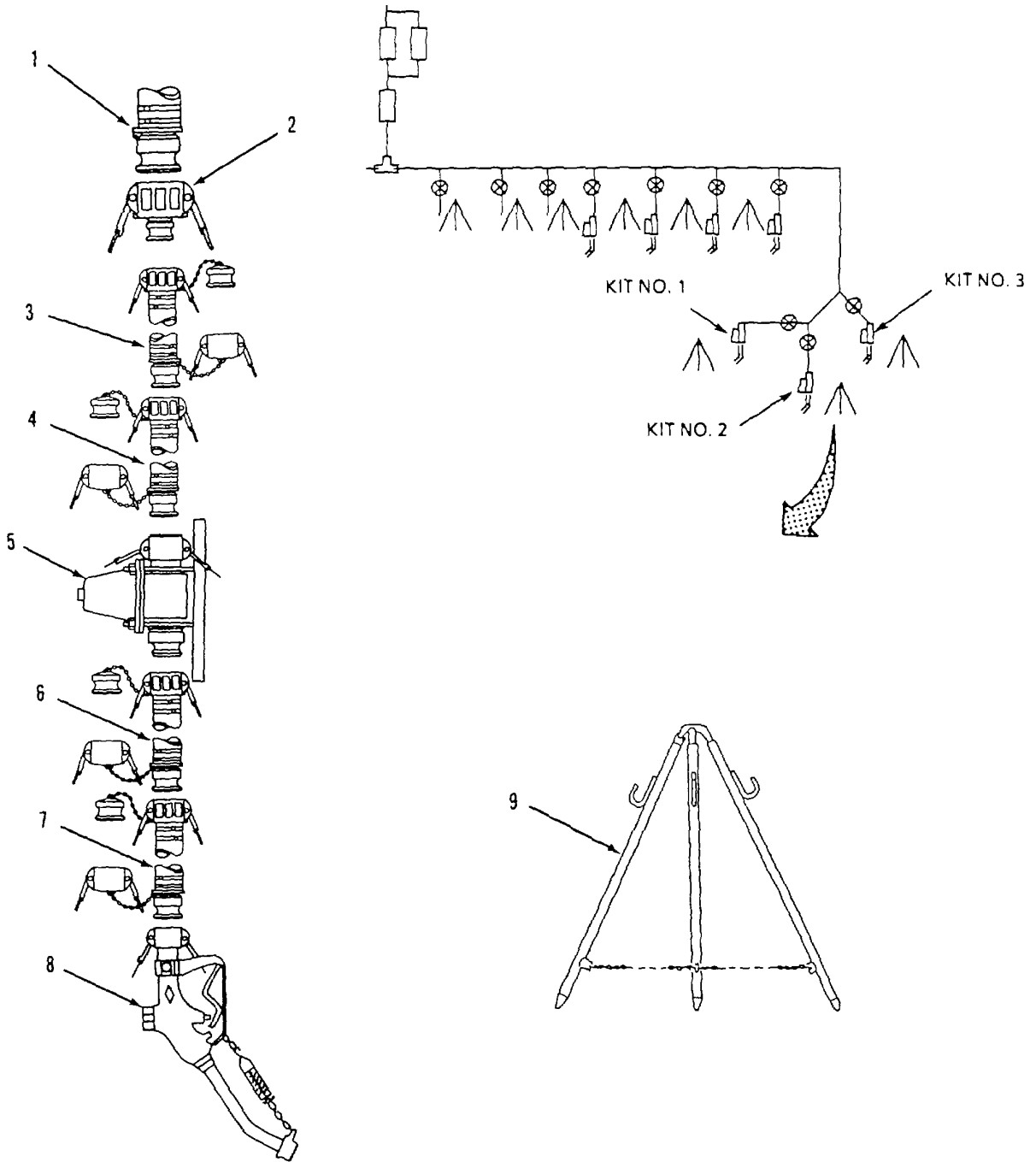

Figure 2-22. Hose and Nozzle Kit Assembly.

2-10. ASSEMBLY AND PREPARATION FOR USE cont.

- p. Assemble 4-Inch Hose Connection Kits. Refer to figure 2-23.

WARNING

To prevent contamination of drinking water, make sure protective caps and plugs are installed when components are not in use. Do not remove caps and plugs from components until couplings are ready to be connected.

NOTE

- Install all valves with control handles in upright position and valves fully closed.
- Two 4-inch hose connection kits are used in the water system. Kit no. 2 is shown, kit no. 1 is similar.
- All couplings in this kit are 4 inch diameter.

- (1) Connect two 20 foot discharge hoses (2 and 3) to tee (1) (from 2-inch hose connection kit).

NOTE

- Do steps (2) through (5) and (10) through (12) below to assemble a 4-inch hose connection kit that uses a quick acting valve (figure 2-23, item 6).
- Do steps (6) through (12) below to assemble a 4-inch hose connection kit that uses the tee and gate valve assembly (figure 2-23, item 10) and an additional hose (item 11).

- (2) Connect tee (4) to 20 foot discharge hose (3).
- (3) Connect quick acting valve (6) to tee (4).
- (4) Connect 20 foot discharge hose (7) to quick acting valve (6).
- (5) Connect butterfly valve (8) to 20 foot discharge hose (7).
- (6) Connect tee and gate valve assembly (10) to discharge hose (3).
- (7) Connect 20 foot discharge hose (7) to tee and gate valve assembly (10).
- (8) Connect 20 foot suction hose (11) to discharge hose (7).
- (9) Connect butterfly valve (8) to 20 foot suction hose (11).
- (10) Unfold nozzle stand assembly (9) and attach butterfly valve (8) to bracket on stand.
- (11) Repeat applicable steps above to assemble kit no. 1.
- (12) On kit no. 1, install cap (5) on open coupling on tee (4) or tee and gate valve assembly (10).

2-10. ASSEMBLY AND PREPARATION FOR USE -Cont.

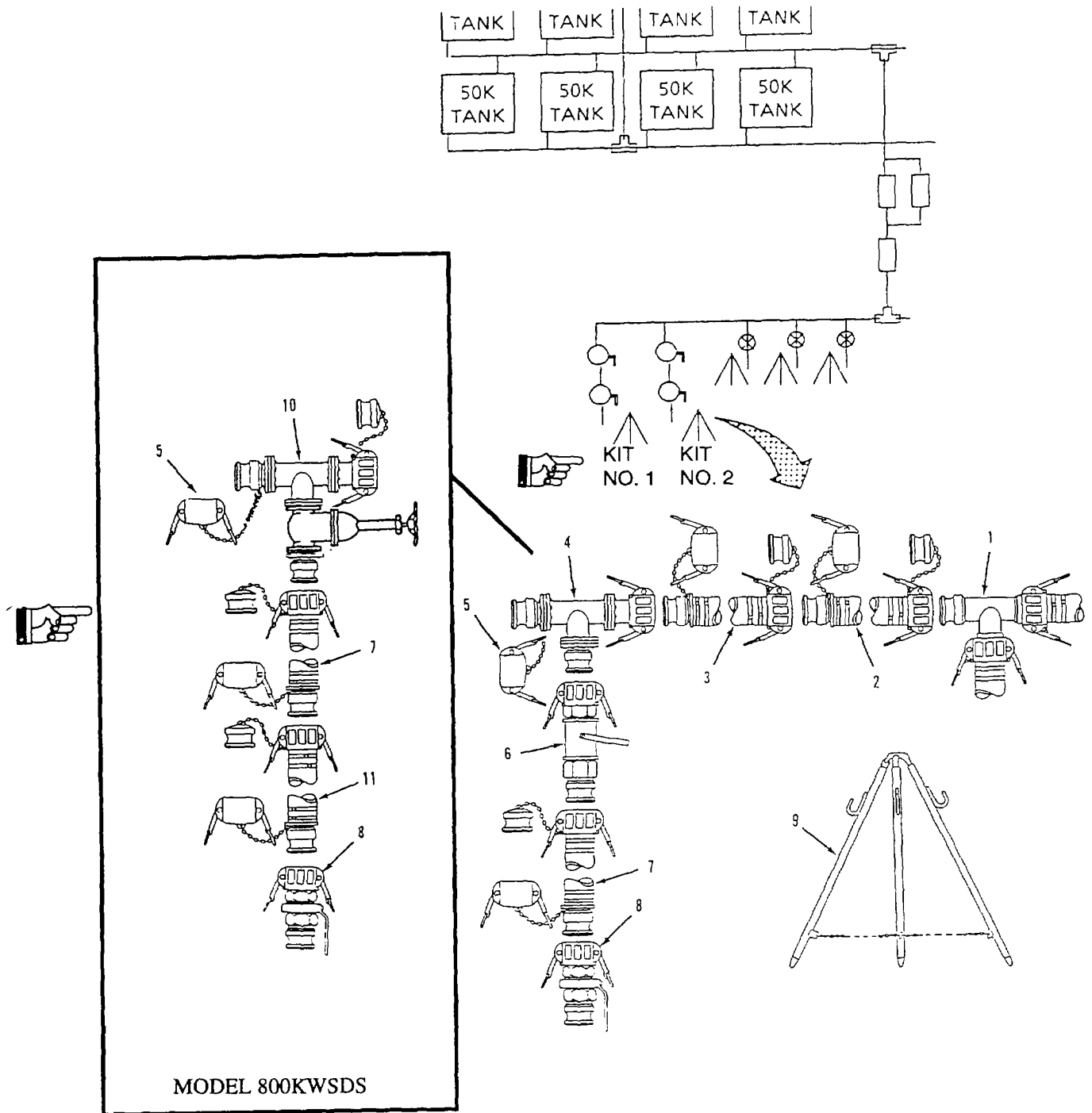

Figure 2-23. 4-Inch Hose Connection Kit Assembly.

2-10. ASSEMBLY AND PREPARATION FOR USE - cont.

- q. Prepare 50K Collapsible Water Tanks. Prepare water tanks for use in accordance with the applicable TM.
- r. Prepare 350 Gpm Pumps. Prepare 350 gpm pumps for use in accordance with the applicable TM.
- s. Prepare 125 Gpm Pumps. Prepare 125 gpm pumps for use in accordance with the applicable TM.
- t. Hypochlorination Unit. Prepare hypochlorination unit for use in accordance with the applicable TM.

2-11. INITIAL ADJUSTMENT

- a. Hoses. Couplings and Valves.
 - (1) Verify that all quick disconnect couplings are securely connected and locked.
 - (2) Verify that caps and plugs are installed on all open tees, fittings and hoses.
 - (3) Inspect suction and discharge hoses for kinks. Straighten out kinks and tight bends.
 - (4) Verify that all gate valves, quick acting valves and butterfly valves are closed.
- b. 50K Collapsible Fabric Tanks. Perform initial adjustments in accordance with the applicable TM.
- c. 350 Gpm Pumps. Perform initial adjustments in accordance with the applicable TM.
- d. 125 Gpm Pumps. Perform initial adjustments in accordance with the applicable TM.
- e. Hypochlorination Unit. Perform initial adjustments in accordance with the applicable TM.

2-12. OPERATING PROCEDURES

- a. General. The 800K Water Storage and Distribution System has two primary modes of operation, fill and discharge. In the fill mode, water is drawn from the water source and stored in the water tanks. During discharge, water is removed from the water tanks and pumped to the distribution points. The water system can operate in both fill mode and discharge mode at the same time.
- b. Water System Diagram. Refer to figure 2-24. Water flow to and from the collapsible fabric tanks is controlled by gate valves identified by the prefix "T". The number following the prefix tells which tank it controls. The suffix "A" indicates that the gate valve controls water flow to the tank. The suffix "B" indicates the gate valve controls water flow from the tank. By opening or closing the respective "A" (inlet) or "B" (outlet) gate valves, the tanks may be filled or discharged.
- c. Startup. Refer to figure 2-24.

2-12 OPERATING PROCEDURES-- cont.*Fill mode***NOTE**

The following procedure describes filling of collapsible water tank T1. Additional tanks, T2 through T16, may be filled by opening their corresponding gate valves (T2A through T16A).

- (1) Open gate valves V1, V2, V3 and V4.
- (2) Open inlet gate valve T1A on tank T1.
- (3) Start and operate the 350 gpm pump P1. Refer to the applicable TM.
- (4) If additional pumping capacity is required, start and operate 125 gpm pump P2. Refer to the applicable TM.

2-12. OPERATING PROCEDURES - cont.

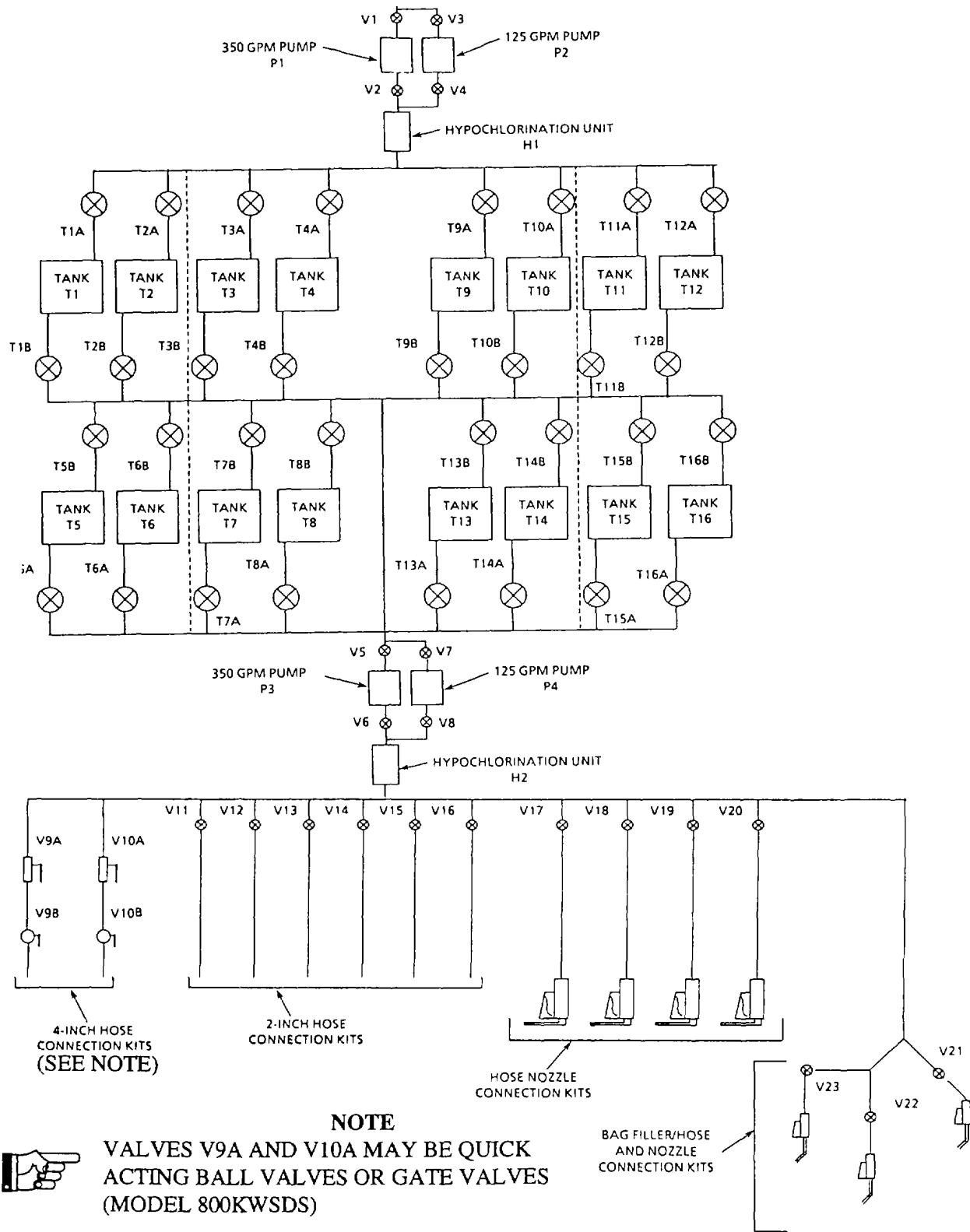

Figure 2-24. Water System Control Valves.

2-12. OPERATING PROCEDURES - cont.

- (5) Start and operate hypochlorination unit H1. Refer to the applicable TM.
- (6) Allow water to flow into tank T1 until full, or required amount of water is stored (refer to the applicable TM), then close gate valve T1A.
- (7) As required, open inlet gate valves T2A through T16A to fill tanks T2 through T16, then close gate valves when tanks are full.
- (8) When fill mode is complete, shutdown 350 gpm pump P1 (refer to the applicable TM) and 125 gpm pump P2 (refer to the applicable TM).

Discharge Mode. Refer to figure 2-24.

- (9) Open gate valves V5, V6 and V7 and V8.

NOTE

The following procedure describes discharge of water from collapsible water tank T1. Additional tanks, T2 through T16, may be discharged by opening their corresponding outlet gate valves (T2B through T16B).

- (10) Open outlet gate valve T1B on tank T1.
- (11) Start and operate hypochlorination unit H2. Refer to the applicable TM.
- (12) Start and operate 125 gpm pump P4. Refer to the applicable TM.
- (13) If additional pumping capacity is required, start and operate 350 gpm pump. Refer to the applicable TM.
- (14) To dispense water through 4-inch hose connection kits, proceed as follows:
 - (a) Connect ends of butterfly valves V9B and V10B to water storage containers.
 - (b) Open butterfly valves V9B and V10B.
 - (c) Open quick acting valves or gate valves V9A and V10A.
 - (d) When storage containers are full, close quick acting valves or gate valves V9A and V10A.
 - (e) Close butterfly valves V9B and V10B and disconnect valves from water storage containers.
- (15) To dispense water through 2-inch hose connection kits, proceed as follows:
 - (a) Connect end of dispensing hose to water storage container.
 - (b) Open gate valves V11, V12, V13, V14, V15 and V16.
 - (c) When water storage containers are full, close gate valves V11, V12, V13, V14, V15 and V16.

2-12. OPERATING PROCEDURES - cont.

- (16) To dispense water through hose nozzle connection kits, proceed as follows:
- (a) Open gate valves V17, V18, V19 and V20.
 - (b) Place distribution nozzles in water storage containers and squeeze distribution nozzle control handles to dispense water.
 - (c) When water storage containers are full, release control handles on distribution nozzles.
 - (d) Close gate valves V17, V18, V19 and V20.
- (17) To dispense water through hose and nozzle connection kits, proceed as follows:
- (a) Open gate valves V21, V22 and V23.
 - (b) Place distribution nozzles in water containers and squeeze distribution nozzle control handles to dispense water.
 - (c) When water storage containers are full, release control handles on distribution nozzles.
 - (d) Close gate valves V21, V22 and V23.
- (18) When discharge mode is complete, shutdown 350 gpm pump P3 (refer to the applicable TM) and 125 gpm pump P4 (refer to the applicable TM).
- d. Shutdown. Refer to figure 2-24.
 - (1) Shut down 350 gpm pump P1. Refer to the applicable TM.
 - (2) Shutdown 125 gpm pump P2. Refer to the applicable TM.
 - (3) Close gate valves V1, V2, V3 and V4.
 - (4) Shut down hypochlorination unit H1. Refer to the applicable TM.
 - (5) Close water tank inlet gate valves T1A through T16A.
 - (6) Close water tank outlet gate valves T1B through T16B.
 - (7) Shutdown 350 gpm pump P3. Refer to the applicable TM.
 - (8) Shutdown 125 gpm pump P4. Refer to the applicable TM.
 - (9) Close gate valves V5, V6, V7 and V8.
 - (10) Shut down hypochlorination unit H2. Refer to the applicable TM.

2-12. OPERATING PROCEDURES - cont.

- (11) Close quick acting valves or gate valves V9A and V10A, and butterfly valves V9B and V10B in 4-inch hose connection kits.
- (12) Close gate valves V11 through V16 in 2-inch hose connection kits.
- (13) Close gate valve V17 through V20 in hose nozzle connection kits.
- (14) Close gate valves V21, V22 and V23 in bag filler connection kit.

2-13. DECALS AND INSTRUCTION PLATES.

Instruction plates are used on the 800K Water Storage and Distribution System to advise the operator of proper operating procedures. Stencils provide additional operating information and cautions to be observed during use of the equipment. Decals and instruction plates appear on major assemblies of the 800K water system.

- a. 350 Gpm Pumps. For decals and instruction plates on the 350 gpm pumps, refer to the applicable TM.
- b. 125 Gpm Pumps. For decals and instruction plates on the 125 gpm pumps, refer to the applicable TM.
- c. 50K Collapsible Fabric Tanks. For decals and instruction plates on the 50,000 gallon collapsible fabric tanks, refer to the applicable TM.
- d. Hypochlorination Unit. For decals and instruction plates on the hypochlorination units, refer to the applicable TM.
- e. Tricon. For decals and instruction plates on the tricons, refer to TM55-8145-200-13&P.
- f. Water Tank Chests. Refer to figure 2-25 for decals and instruction plates on the tank chests.

2-13. DECALS AND INSTRUCTION PLATES - cont.

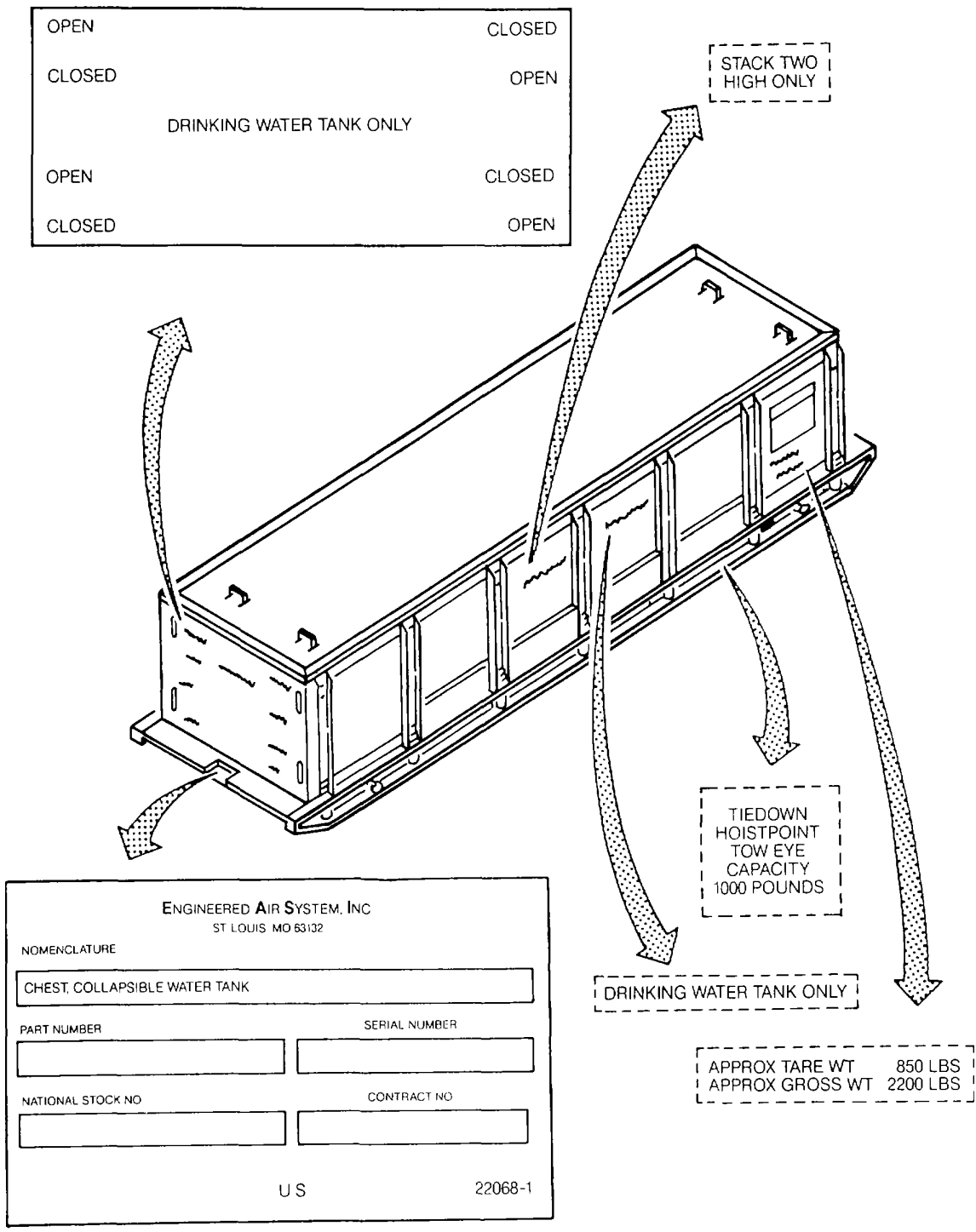

Figure 2-25. Decals and Instruction Plates.

2-14. OPERATING AUXILIARY EQUIPMENT.**WARNING**

Engine driven water pumps must not be operated in enclosed areas unless exhaust discharge is properly vented to the outside. Be alert at all times during operation for odors and symptoms of carbon monoxide exposure.

- a. 350 Gpm Pumps. Instructions for operating the 350 gpm pumps are contained in the applicable TM.
- b. 125 Gpm Pumps. Instructions for operating the 125 gpm pumps are contained in the applicable TM.
- c. 50K Collapsible Fabric Tanks. Instructions for operating the 20,000 gallon collapsible fabric tanks are contained in the applicable TM.

WARNING

Chemicals used for operating the hypochlorination unit can kill you. The chemicals alone or in mixture can be dangerous. Always wear protective apron, goggles and gloves, and make sure area is well ventilated.

- d. Hypochlorination Unit. Instructions for operating the hypochlorination units are contained in the applicable TM.
- e. Tricon. Instructions for operating the tricons are contained in TiM55-8145-200-13&P.

2-15. PREPARATION FOR MOVEMENT.**WARNING**

- To prevent contamination of water system components, keep dirt, mud, sand, and debris from entering open couplings during disassembly. Make sure protective caps and plugs are installed after components are disassembled.
- To prevent injury to personnel, all water pumps must be shutdown and water pressure relieved from discharge hoses before disconnecting couplings.

- a. Drain Collapsible Fabric Tanks. Drain water from all collapsible fabric tanks. Refer to the applicable TM.
- b. Disassemble hose and Nozzle Kits. Refer to figure 2-26.

NOTE

Three hose and nozzle kits are used in the water system. One is shown, the others are similar.

- (1) Remove distribution nozzle (8) from bracket on nozzle stand assembly (9). Fold nozzle stand assembly.
- (2) Disconnect distribution nozzle (8) from 1 inch x 10 foot discharge hose (7).
- (3) Disconnect two 1 inch x 10 foot discharge hoses (6 and 7) from regulator (5).

2-15. PREPARATION FOR MOVEMENT - cont.

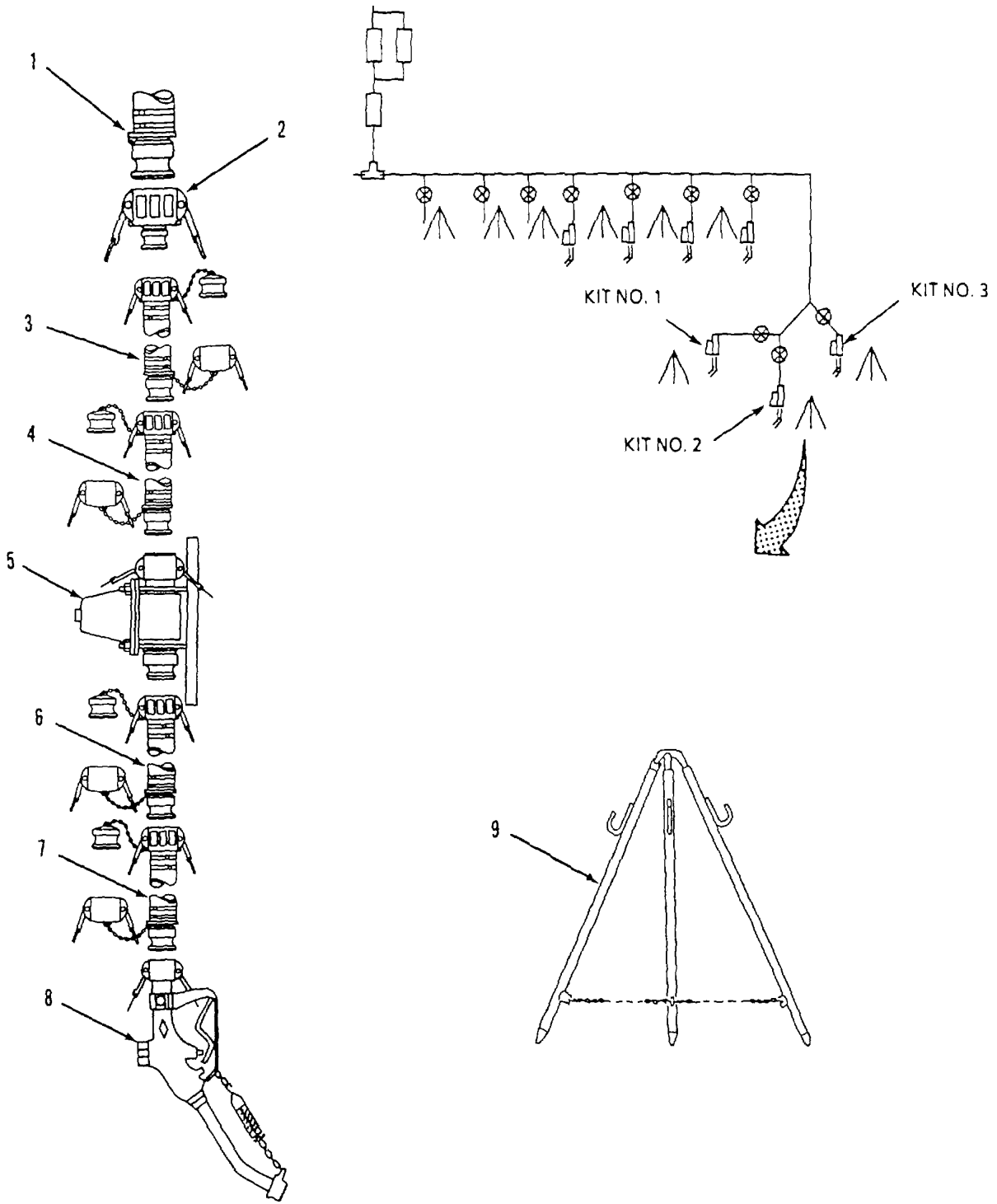

Figure 2-26. Hose and Nozzle Kit Disassembly.

2-15. PREPARATION FOR MOVEMENT-cont.

- (4) Disconnect regulator (5) from 1 inch x 10 foot discharge hose (4).
- (5) Disconnect two 1 inch x 10 foot discharge hoses (3 and 4) from adapter (2).
- (6) Disconnect adapter (1-½ inch female x 1 inch male) (2) from 1-½ inch x 25 foot discharge hose (1) (from bag filler connection kit).
- (7) Repeat steps 1 through 6 for remaining hose and nozzle kits.
- (8) Drain and allow components to dry.
- (9) Install caps and plugs on couplings (para 2-10c).

- c. Disassemble Bag Filler Connection Kits. Refer to figure 2-27.

WARNING

- To prevent contamination of water system components, keep dirt, mud, sand, and debris from entering open couplings during disassembly. Make sure protective caps and plugs are installed after components are disassembled.
- To prevent injury to personnel, all water pumps must be shutdown and water pressure relieved from discharge hoses before disconnecting couplings.

- (1) Disconnect 1-½ inch x 25 foot discharge hose (17) from 2 inch gate valve (16).
- (2) Disconnect 2 inch gate valve (16) from wye (13).
- (3) Disconnect 1-½ inch x 25 foot discharge hose (15) from 2 inch gate valve (14).
- (4) Disconnect 2 inch gate valve (14) from wye (13).
- (5) Disconnect wye (13) from 2 inch x 20 foot discharge hose (12).
- (6) Disconnect 2 inch x 20 foot discharge hose (12) from wye (8).
- (7) Disconnect 1-½ inch x 25 foot discharge hose (11) from 2 inch gate valve (10).
- (8) Disconnect 2 inch gate valve (10) from 2 inch x 20 foot discharge hose (9).
- (9) Disconnect 2 inch x 20 foot discharge hose (9) from wye (8).
- (10) Disconnect wye (8) from 2 inch x 20 foot discharge hose (7).
- (11) Disconnect 2 inch x 20 foot discharge hose (7) from adapter (6).
- (12) Disconnect adapter (4 inch female x 2 inch male) (6) from tee (5).
- (13) Disconnect tee (4) from 4 inch x 20 foot discharge hose (3).

2-15. PREPARATION FOR MOVEMENT - cont.

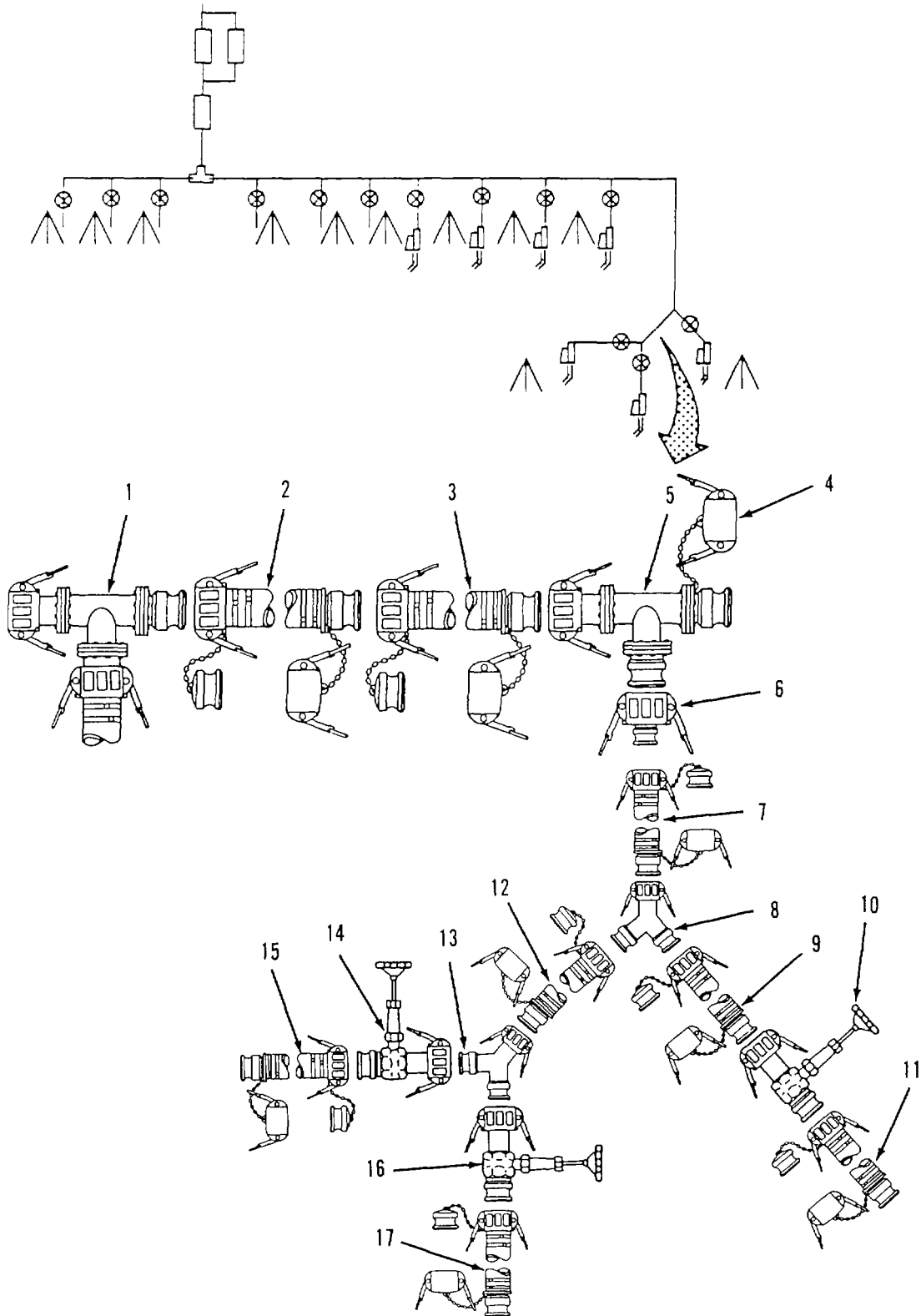

Figure 2-27. Bag Filter Connection Kit Disassembly.

2-15. PREPARATION FOR MOVEMENT - cont.

- (14) Disconnect 4 inch x 20 foot discharge hose (3) from 4 inch x 20 foot discharge hose (2).
- (15) Disconnect 4 inch x 20 foot discharge hose (2) from tee (1) (from hose nozzle connection kit no. 4).
- (16) Drain and allow components to dry
- (17) Install caps and plugs on component couplings (para 2-10c).
- (18) Roll all discharge hoses and secure with tape.

d. Disassemble Hose Nozzle Connection Kits. Refer to Figure 2-28.

WARNING

- To prevent contamination of water system components, keep dirt mud, sand, and debris from entering open couplings during disassembly. Make sure protective caps and plugs are installed after components are disassembled
- To prevent injury to personnel, all water pumps must be shutdown and water pressure relieved from discharge hoses before disconnecting couplings.

NOTE

Four hose nozzle connection kits are used in the water system. One is shown, the others are similar.

- (1) Remove distribution nozzle (10) from nozzle stand assembly (11) and fold stand.
- (2) Disconnect distribution nozzle (10) from 1-1/2 inch x 25 foot discharge hose (9).
- (3) Disconnect 1-1/2 inch x 25 foot discharge hose (9) from adapter (8).
- (4) Disconnect adapter (2 inch female x 1-1/2 inch male) (8) from 2 inch x 20 foot discharge hose (7).
- (5) Disconnect 2 inch x 20 foot discharge hose (7) from gate valve (6).
- (6) Disconnect 2-inch gate valve (6) from adapter (5).
- (7) Disconnect adapter (4 inch female x 2-inch male) (5) from tee (4).
- (8) Disconnect tee (4) from 4 inch x 20 foot discharge hose (3).
- (9) Disconnect 4 inch x 20 foot discharge hose (3) from 4 inch x 20 foot discharge hose (2)
- (10) Disconnect 4 inch x 20 foot discharge hose (2) from tee assembly (1) (2-inch hose disconnection kit).
- (11) Repeat steps 1 through 10 for remaining hose nozzle connection kits.
- (12) Drain and allow components to dry.

2-15. PREPARATION FOR MOVEMENT - cont.

- (13) Install caps and plugs on component couplings (para. 2-10c).
- (14) Roll all discharge hoses and secure with tape.

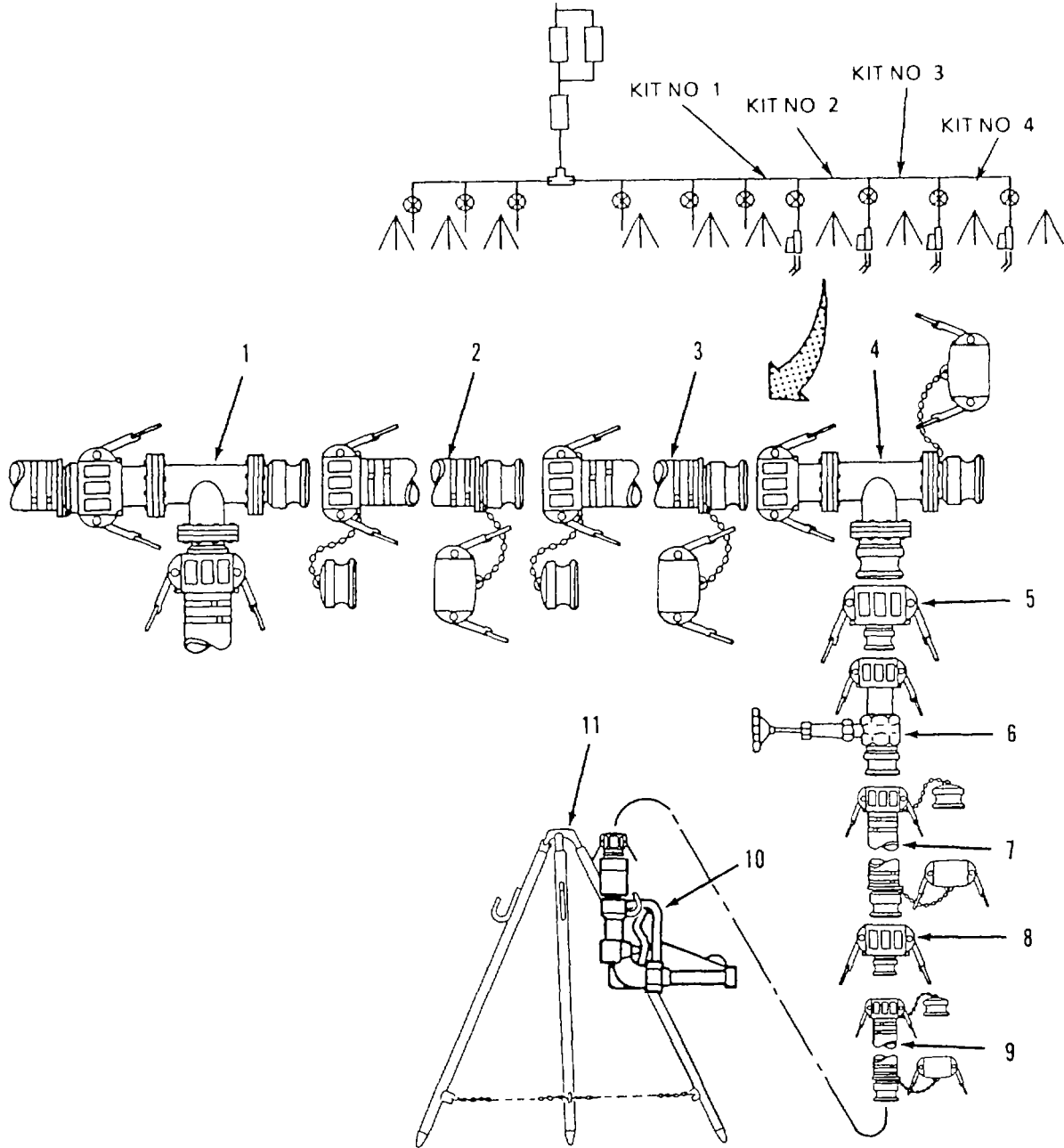

Figure 2-28. Hose Nozzle Connection Kit Disassembly

2-15. PREPARATION FOR MOVEMENT - cont.

- e. Disassemble 2-Inch lose Connection Kits . Refer to figure 2-29.

WARNING

- To prevent contamination of water system components, keep dirt mud, sand, and debris from entering open couplings during disassembly. Make sure protective caps and plugs are installed after components are disassembled.
- To prevent injury to personnel, all water pumps must be shutdown and water pressure relieved from discharge hoses before disconnecting couplings.

NOTE

Six 2-inch hose connection kits are used in the water system. Kits 1, 2 and 3 are a mirror image of kits 4, 5 and 6

2-Inch Hose Connection Kit No. 6.

- (1) Remove discharge hose (14) from nozzle stand assembly (15) Fold nozzle stand.
- (2) Disconnect 2 inch x 20 foot discharge hose (14) from 2-inch gate valve (13).
- (3) Disconnect 2-inch gate valve (13) from adapter (12).
- (4) Disconnect adapter (4-inch female x 2-inch male) (12) from tee (11).
- (5) Disconnect tee (11) from 4 inch x 20 foot discharge hose (10).
- (6) Disconnect 4 inch x 20 foot discharge hose (10) from 4 inch x 20 foot discharge hose (9).
- (7) Disconnect 4-inch x 20 foot discharge hose (9) from tee (11) from previous kit.
- (8) Disconnect 4 inch x 20 foot discharge hose (9) from tee (8) from 350 gpm pump disconnection kit.
- (9) Repeat steps I through 8 for hose connection kits 5 and 4.

2-Inch Hose Disconnection Kits No. 3.

- (10) Remove discharge hose (6) from nozzle stand assembly (7). Fold nozzle stand.
- (11) Disconnect 2 inch x 20 foot discharge hose (6) from 2-inch gate valve (5).
- (12) Disconnect 2-inch gate valve (5) from adapter (4).
- (13) Disconnect adapter (4-inch female x 2-inch male) (4) from tee (3).
- (14) Disconnect tee (3) from 4 inch x 20 foot discharge hose (2).
- (15) Disconnect 4 inch x 20 foot discharge hose (2) from 4 inch x 20 foot discharge hose (1).
- (16) Disconnect 4-inch x 20 foot discharge hose (1) from tee (3) from previous kit.

2-15. PREPARATION FOR MOVEMENT - cont.

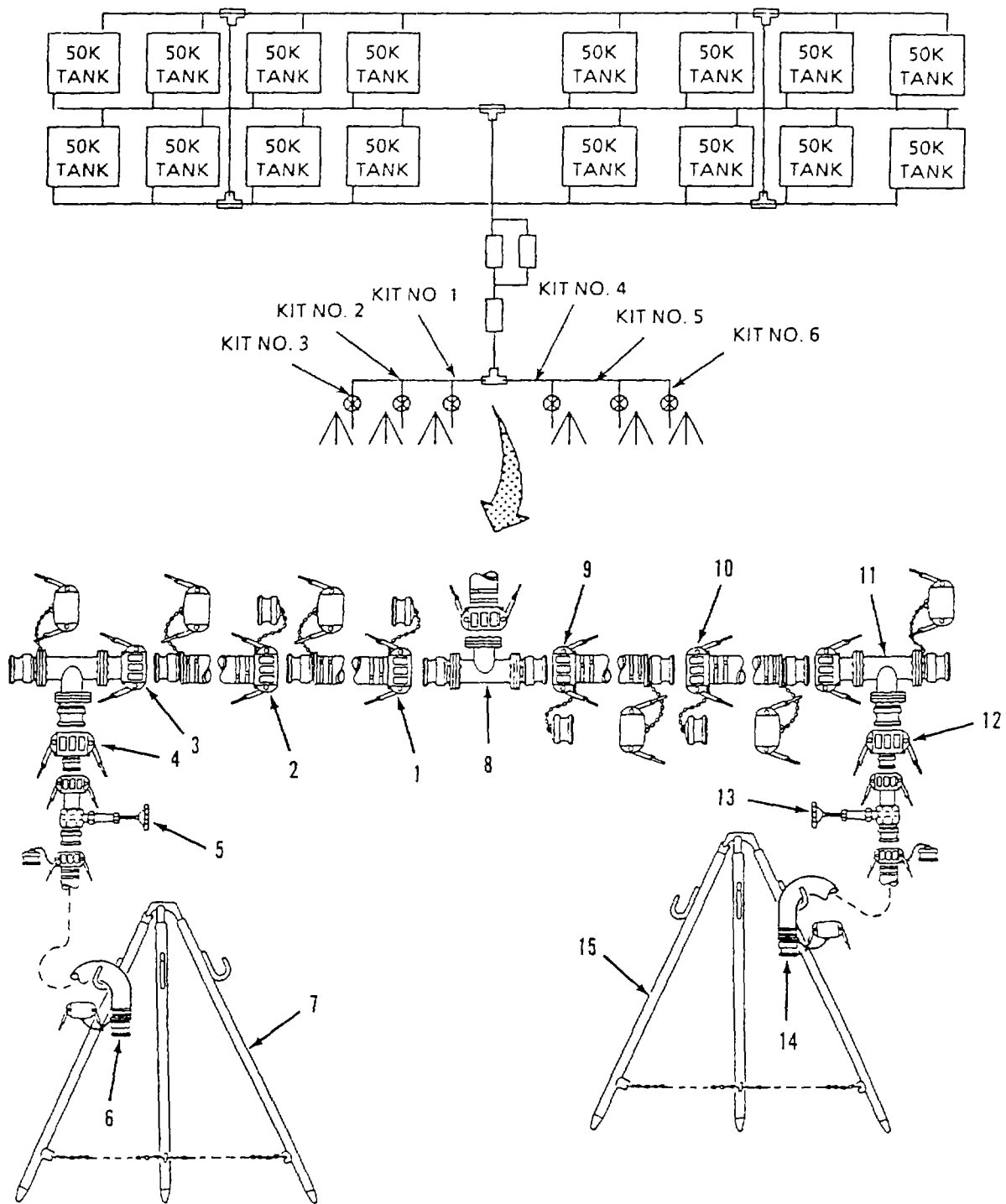

Figure 2-29. 2-Inch Hose Connection Kit Disassembly.

2-15. PREPARATION FOR MOVEMENT - cont.

- (17) Disconnect 4 inch x 20 foot discharge hose (1) from tee (8).
- (18) Repeat steps 10 through 16 for hose connection kit no. 1.
- (19) Drain and allow components to dry.
- (20) Install caps and plugs on component couplings (para. 2-10c).
- (21) Roll all discharge hoses and secure with tape.

- f. Disassemble 4-Inch Hose Connection Kits Refer to figure 2-30.

WARNING

- To prevent contamination of water system components, keep dirt, mud, sand, and debris from entering open couplings during disassembly. Make sure protective caps and plugs are installed after components are disassembled.
- To prevent injury to personnel, the water pump must be shutdown and water pressure relieved from discharge hoses before disconnecting couplings.

NOTE

Two 4-inch hose connection kits are used in the water system. Kit no. 1 is shown, kit no. 2 is similar.

- (1) Remove butterfly valve (8) from bracket on stand assembly (9). Fold nozzle stand.

NOTE

- Do steps (2) through (5) and (10) through (14) below to disassemble a 4-inch hose connection kit that uses a quick acting valve (figure 2-30, item 6).
- Do steps (6) through (14) below to disassemble a 4-inch hose connection kit that uses the tee and gate valve assembly (figure 2-30, item 10) and an additional hose (item 11).

- (2) Disconnect butterfly valve (8) from 20 foot discharge hose (7).
- (3) Disconnect 20 foot discharge hose (7) from quick acting valve (6).
- (4) Disconnect quick acting valve (6) from tee (4).
- (5) Disconnect tee (4) from 20 foot discharge hose (3).
- (6) Disconnect butterfly valve (8) from 20 foot suction hose (11).
- (7) Disconnect 20 foot suction hose (11) from discharge hose (7).
- (8) Disconnect 20 foot discharge hose (7) from tee and gate valve assembly (10).
- (9) Disconnect tee and gate valve assembly (10) from discharge hose (3).
- (10) Disconnect two 20 foot discharge hoses (2 and 3) from tee (1).
- (11) Repeat applicable steps above to disassemble kit no. 1.

2-15. PREPARATION FOR MOVEMENT - cont.

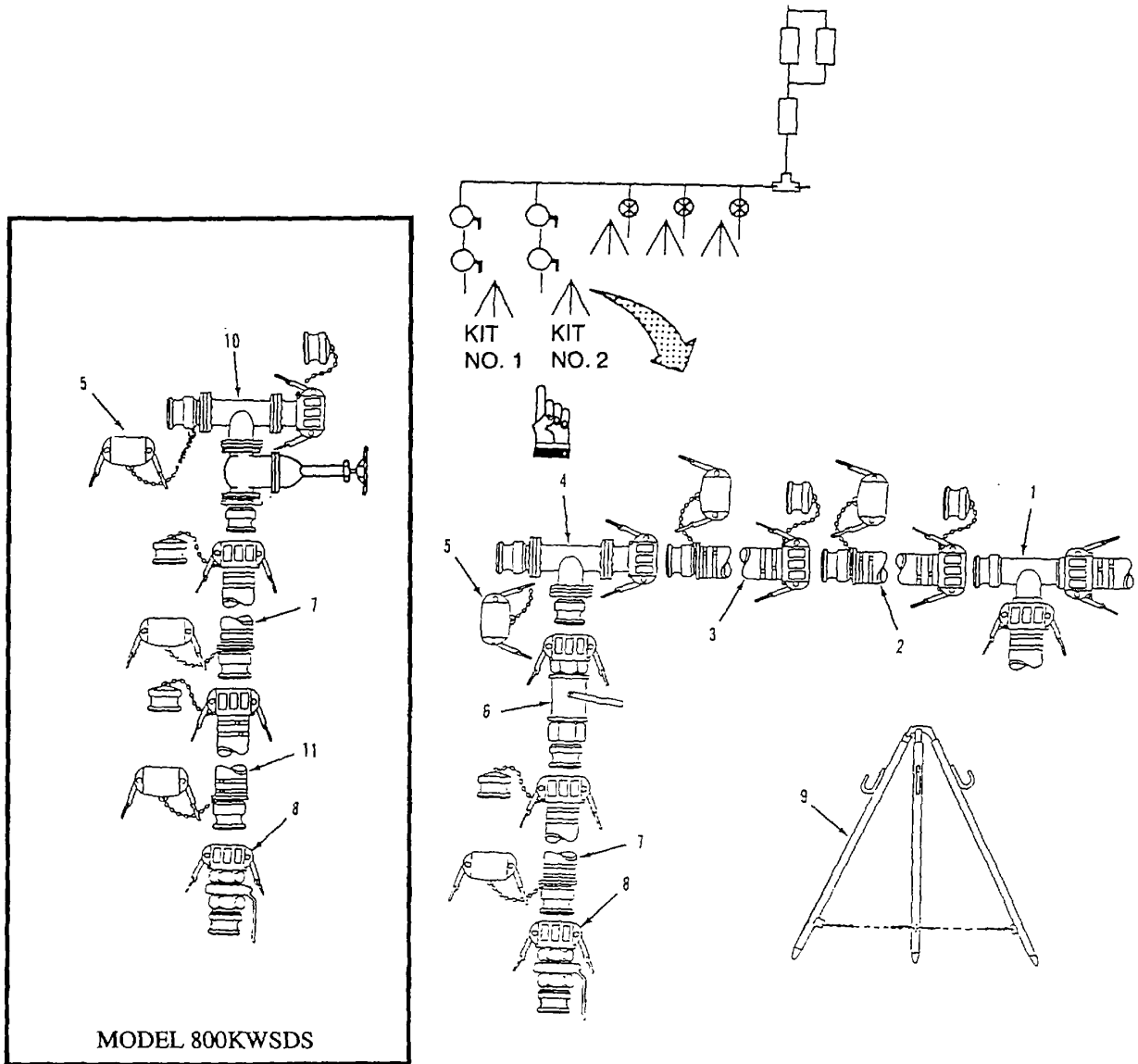

Figure 2-30. 4-Inch Hose Connection Kit Disassembly.

2-15. PREPARATION FOR MOVEMENT - cont.

- (12) Drain and allow components to dry.
- (13) Install caps and plugs on component couplings (para. 2-10c).
- (14) Roll up all discharge hoses and secure with tape.

g. Disassemble 125 Gpm Pump Connection Kit (Distribution Point). Refer to figure 2-31.

WARNING

- To prevent contamination of water system components, keep dirt, mud, sand, and debris from entering open couplings during disassembly. Make sure protective caps and plugs are installed after components are disassembled.
 - To prevent injury to personnel, the water pump must be shutdown and water pressure relieved from discharge hoses before disconnecting couplings.
- (1) Disconnect end of 20 foot discharge hose (12) from adapter (13).
 - (2) Disconnect adapter (4-inch male x 2-inch female) (13) from tee (14) (part of 350 gpm pump connection kit).
 - (3) Disconnect 20 foot discharge hose (12) from 2-inch gate valve (11).
 - (4) Disconnect 2-inch gate valve (11) from check valve (10).
 - (5) Disconnect check valve (10) from 20 foot discharge hose (9).
 - (6) Disconnect 20 foot discharge hose (9) from male (discharge) coupling (8) on 125 gpm pump (6).
 - (7) Disconnect end of 20 foot suction hose (5) from female (suction) coupling (7) on 125 gpm pump (6).
 - (8) Disconnect 20 foot suction hose (5) from 2-inch gate valve (4).
 - (9) Disconnect 2-inch gate valve (4) from 20 foot suction hose (3).
 - (10) Disconnect 20 foot suction hose (3) from adapter (2).
 - (11) Disconnect adapter (4-inch female x 2-inch male) (2) from tee (1) (part of 350 gpm pump connection kit).
 - (12) Drain and allow components to dry.
 - (13) Install caps and plugs on component couplings (para. 2-10c).
 - (14) Roll up all discharge hoses and secure with tape.
 - (15) Prepare 125 gpm pump (6) for movement. Refer to applicable TM.

2-15. PREPARATION FOR MOVEMENT - cont.

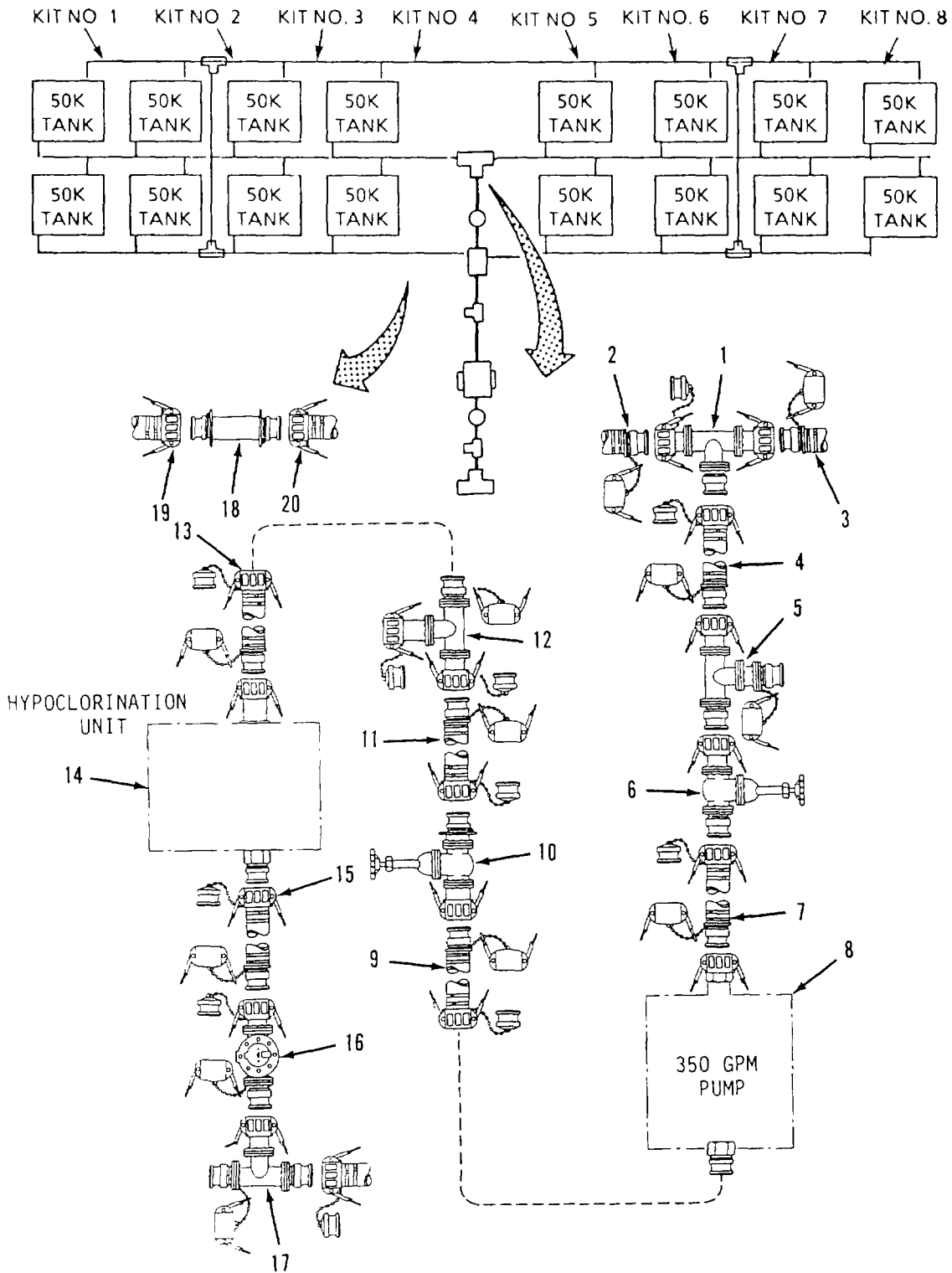

Figure 2-31. 125 Gpm Pump Connection Kit (Distribution Point) Disassembly.

2-15. PREPARATION FOR MOVEMENT - cont.

h. Disassemble 350 Gpm Pump Connection Kit (Distribution Point). Refer to Figure 2-32.

WARNING

- To prevent contamination of water system components, keep dirt mud, sand, and debris from entering open couplings during disassembly. Make sure protective caps and plugs are installed after components are disassembled.
 - To prevent injury to personnel, all water pumps must be shutdown and water pressure relieved from discharge hoses before disconnecting couplings.
- (1) Disconnect 10 foot discharge hose (20) (part of dual tank connection kit no 5) from adapter (18).
 - (2) Disconnect male x male adapter (18) from 10 foot discharge hose (19) (part of dual tank connection kit 4).
 - (3) Disconnect tee (17) from water meter (16).
 - (4) Disconnect water meter (16) from 20 foot discharge hose (15).
 - (5) Disconnect 20 foot discharge hose (15) from male (outlet) coupling on hypochlorination unit (14).
 - (6) Disconnect end of 20 foot discharge hose (13) from female (inlet) coupling on hypochlorination unit (14).
 - (7) Disconnect 20 foot discharge hose (13) from tee (12).
 - (8) Disconnect tee (12) from 20 foot discharge hose (11).
 - (9) Disconnect 20 foot discharge hose (11) from 4-inch gate valve (10).
 - (10) Disconnect 4-inch gate valve (10) from 20 foot discharge hose (9).
 - (11) Disconnect of 20 foot discharge hose (9) from male (discharge) coupling on 350 gpm pump (8).
 - (12) Disconnect 20 foot suction hose (7) from female (suction) coupling on 350 gpm pump (8).
 - (13) Disconnect 20 foot suction hose (7) from 4-inch gate valve (6).
 - (14) Disconnect 4-inch gate valve (6) from tee (5).
 - (15) Disconnect tee (5) from 20 foot suction hose (4).
 - (16) Disconnect 20 foot suction hose (4) from tee (1).
 - (17) Disconnect 10 foot discharge hose (2) (part of dual tank connect kit no. 4) from tee (1).
 - (18) Disconnect 20 foot discharge hose (3) (part of dual tank connection kit no. 5) from tee (1).

2-15. PREPARATION FOR MOVEMENT - cont.

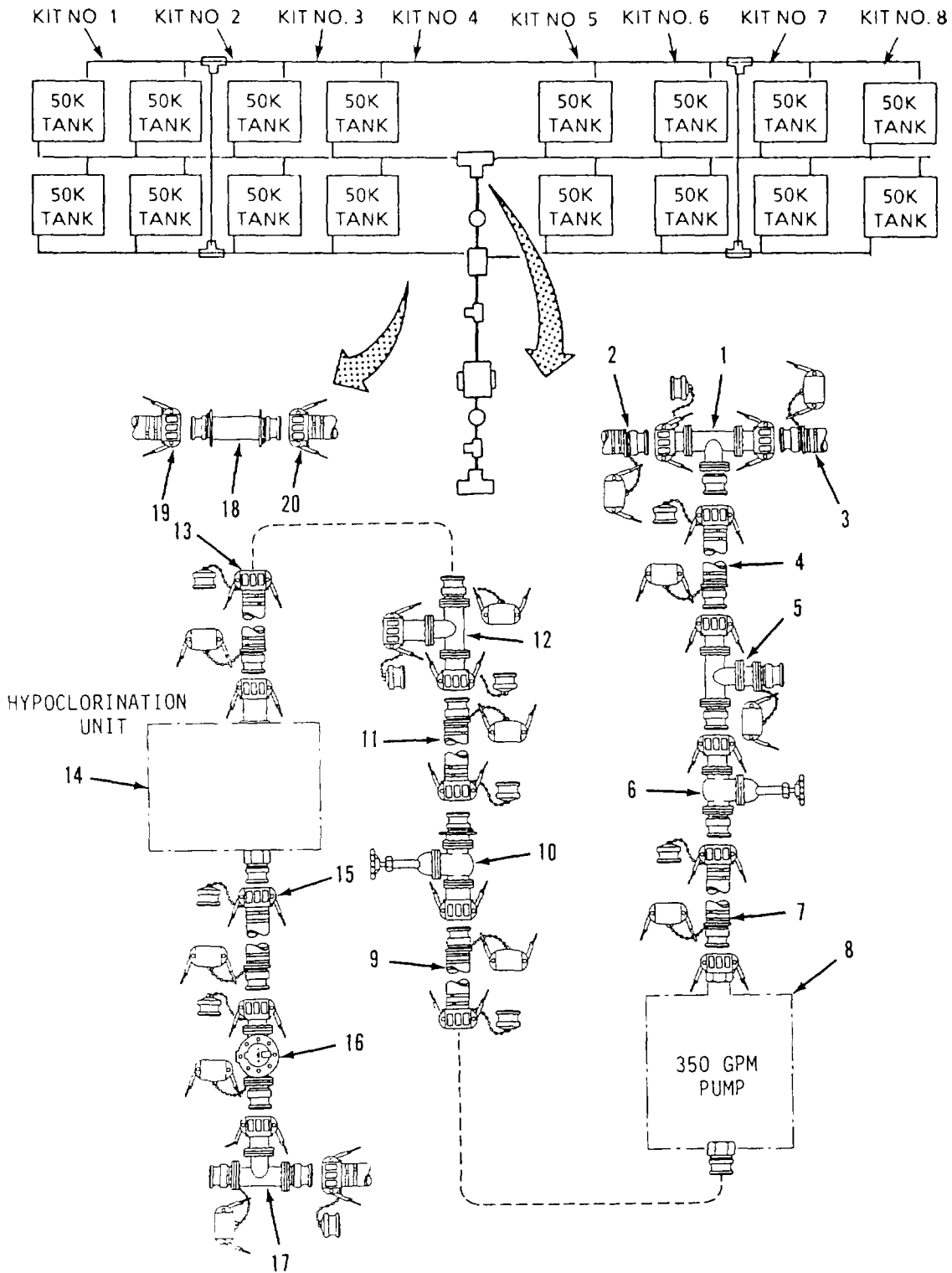

Figure 2-32. 350 Gpm Pump Connection Kit (Distribution Point) Disassembly.

2-15. PREPARATION FOR MOVEMENT - cont.

- (19) Prepare hypochlorination unit (14) for movement. Refer to the applicable TIM.
- (20) Prepare 350 gpm pump (8) for movement. Refer to the applicable TM.
- (21) Drain and allow components to dry.
- (22) Install caps and plugs on component couplings (para 2-10c).
- (23) Roll up all discharge hoses and secure with tape.

i. Disassemble 125 GPM Pump Assembly Connection Kit (Water Source). Refer to figure 2-33.**WARNING**

- To prevent contamination of water system components, keep dirt, mud, sand, and debris from entering open couplings during disassembly. Make sure protective caps and plugs are installed after components are disassembled.
- To prevent injury to personnel, all water pumps must be shutdown and water pressure relieved from discharge hoses before disconnecting couplings.

- (1) Disconnect end of 20 foot discharge hose (12) from adapter (13).
- (2) Disconnect adapter (4-inch male x 2-inch female) (13) from tee (14) (part of 350 gpm pump connection kit).
- (3) Disconnect 20 foot discharge hose (12) from 2-inch gate valve (11).
- (4) Disconnect 2-inch gate valve (11) from check valve (10).
- (5) Disconnect check valve (10) from 20 foot discharge hose (9).
- (6) Disconnect 20 foot discharge hose (9) from male (discharge) coupling (8) on 125 gpm pump (6).
- (7) Disconnect end of 20 foot suction hose (5) from female (suction) coupling (7) on 125 gpm pump (6).
- (8) Disconnect 20 foot suction hose (5) from 2-inch gate valve (4).
- (9) Disconnect 2-inch gate valve (4) from 20 foot suction hose (3).
- (10) Disconnect 20 foot suction hose (3) from adapter (2).
- (11) Disconnect adapter (4-inch female x 2-inch male) (2) from tee (1) (part of 350 gpm pump connection kit).
- (12) Drain and allow components to dry.
- (13) Install caps and plugs on component couplings (para 2-10c).

2-15. PREPARATION FOR MOVEMENT - cont.

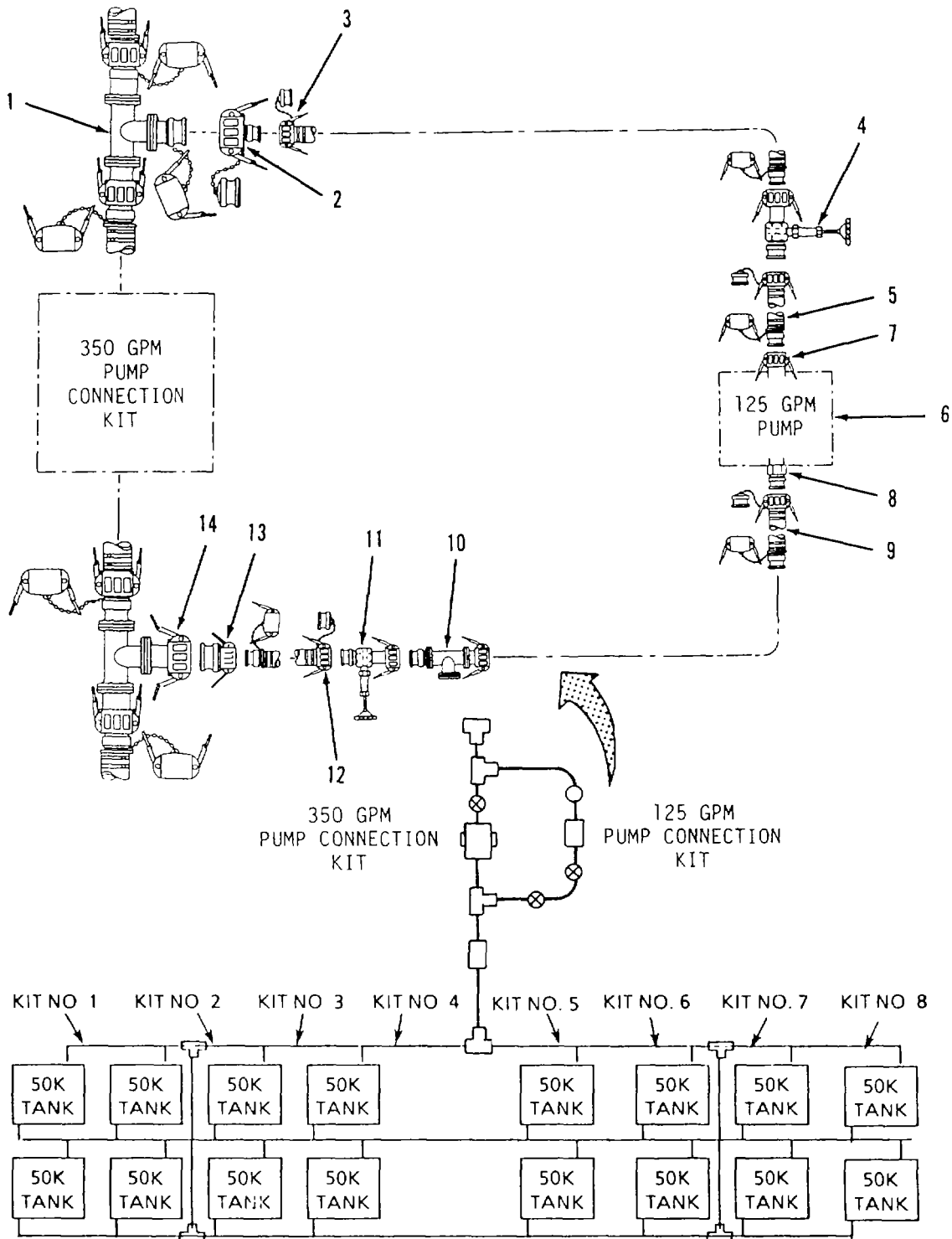

Figure 2-33. 125 GPM Pump Assembly Connection Kit (Water Source)

2-15. PREPARATION FOR MOVEMENT - cont.

(14) Roll up all discharge hoses and secure with tape.

(15) Prepare 125 gpm pump (6) for movement. Refer to the applicable TM.

j. Disassemble 350 Gpm Pump Connection Kit (Water Source). Refer to figure 2-34.

WARNING

- To prevent contamination of water system components, keep dirt, mud, sand, and debris from entering open couplings during disassembly. Make sure protective caps and plugs are installed after components are disassembled.
- To prevent injury to personnel, all water pumps must be shutdown and water pressure relieved from discharge hoses before disconnecting couplings.

- (1) Disconnect 10 foot discharge hose (3) (part of dual tank connection kit 4) from tee (1).
- (2) Disconnect 10 foot discharge hose (2) (part of dual tank connection kit 5) from tee (1).
- (3) Disconnect water meter (4) from tee (1).
- (4) Disconnect water meter (4) from 20 foot discharge hose (5).
- (5) Disconnect 20 foot discharge hose (5) from male (outlet) coupling on hypochlorination unit (6).
- (6) Disconnect 20 foot discharge hose (7) from female (inlet) coupling on hypochlorination unit (6).
- (7) Disconnect tee (8) from 20 foot discharge hose (7).
- (8) Disconnect 20 foot discharge hose (9) from tee (8).
- (9) Disconnect 4-inch gate valve (10) from 20 foot discharge hose (9).
- (10) Disconnect 20 foot discharge hose (11) from 4-inch gate valve (10).
- (11) Disconnect end of 20 foot discharge hose (11) from male (discharge) coupling on 350 gpm pump (12).
- (12) Disconnect 20 foot suction hose (13) from female (suction) coupling on 350 gpm pump (12).
- (13) Disconnect 4-inch gate valve (14) from 20 foot suction hose (13).

2-15. PREPARATION FOR MOVEMENT - cont.

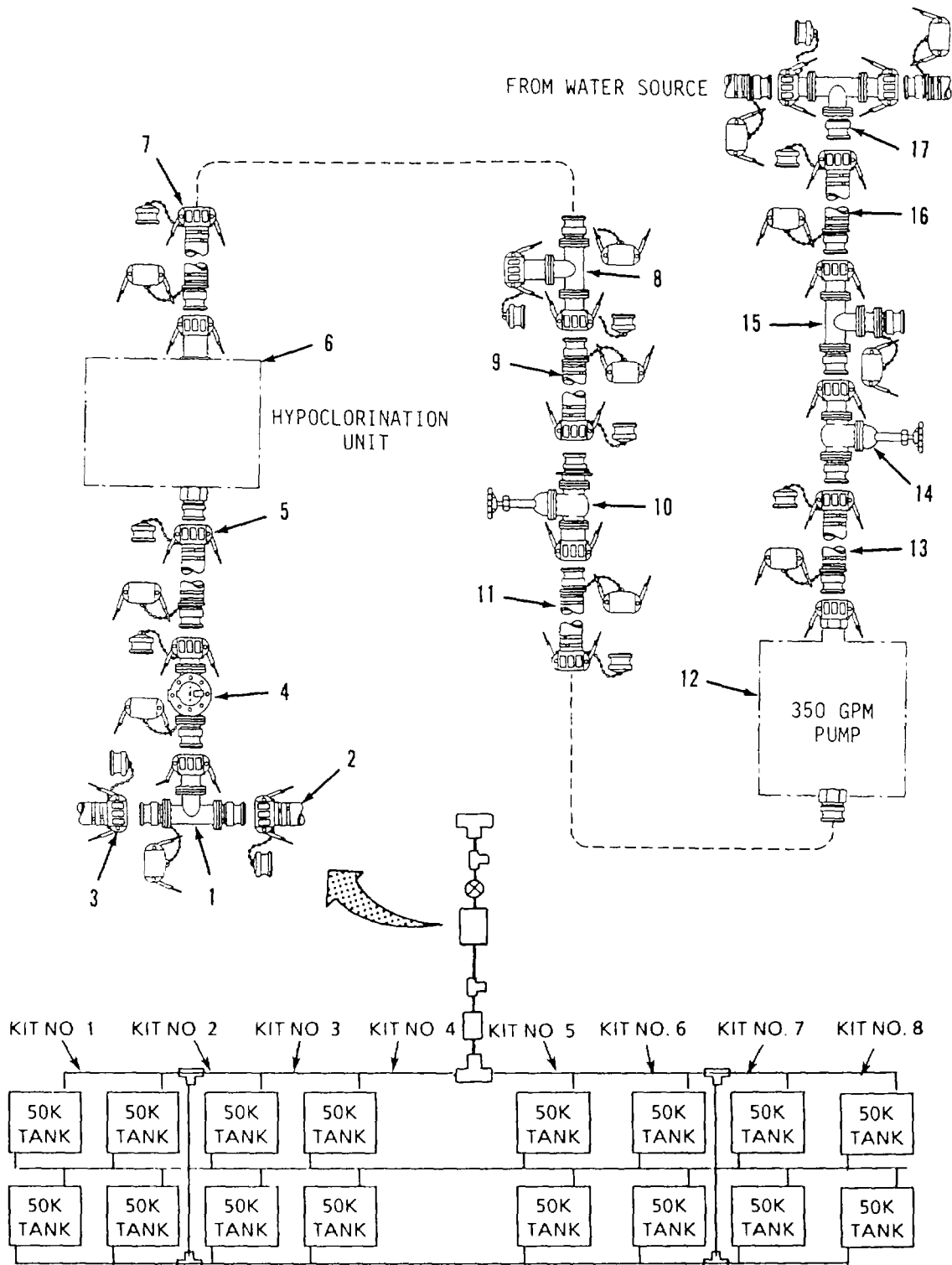

Figure 2-34. 350 Gpm Pump Connection Kit (Water Source) Disassembly.

2-15. PREPARATION FOR MOVEMENT - cont.

- (14) Disconnect tee (15) from 4-inch gate valve (14).
- (15) Disconnect 20 foot suction hose (16) from tee (15).
- (16) Disconnect tee (17) from 20 foot suction hose (16).
- (17) Disconnect tee (17) from water source.
- (18) Drain and allow components to dry.
- (19) Install caps and plugs on component couplings (para. 2-10c).
- (20) Roll up all discharge hoses and secure with tape.
- (21) Prepare hypochlorination unit (6) for movement. Refer to the applicable TM.
- (22) Prepare 350 gpm pump (12) for movement Refer to the applicable TM.

- k. Disassemble Interconnection Kits. Two interconnection kits are supplied with the water system. One kit is located between dual tank connection kits 2 and 3 and the other between kits 6 and 7.

WARNING

- To prevent contamination of water system components, keep dirt mud, sand, and debris from entering open couplings during disassembly. Make sure protective caps and plugs are installed after components are disassembled.
- To prevent injury to personnel, water pressure must be relieved from discharge hoses before disconnecting couplings.

Disassemble interconnection kit between dual tank connection kits 2 and 3. Refer to figure 2-35, sheet 1.

- (1) Disconnect end of 20 foot discharge hose (7) from tee (8).
- (2) Disconnect end of 10 foot discharge hose (10) from tee (8).
- (3) Disconnect tee (8) from 20 foot discharge hose (9).
- (4) Disconnect four 20 foot discharge hoses (4, 5, 6, and 7) from tee (3).
- (5) Disconnect 10 foot discharge hose (1) from tee (3).
- (6) Disconnect tee (3) from 20 foot discharge hose (1).

Dissemble interconnection kit between dual tank connection kits 6 and 7. Refer to figure 2-35, sheet 2.

- (7) Repeat steps (1) through (6) for other interconnection kit.

2-15. PREPARATION FOR MOVEMENT - cont.

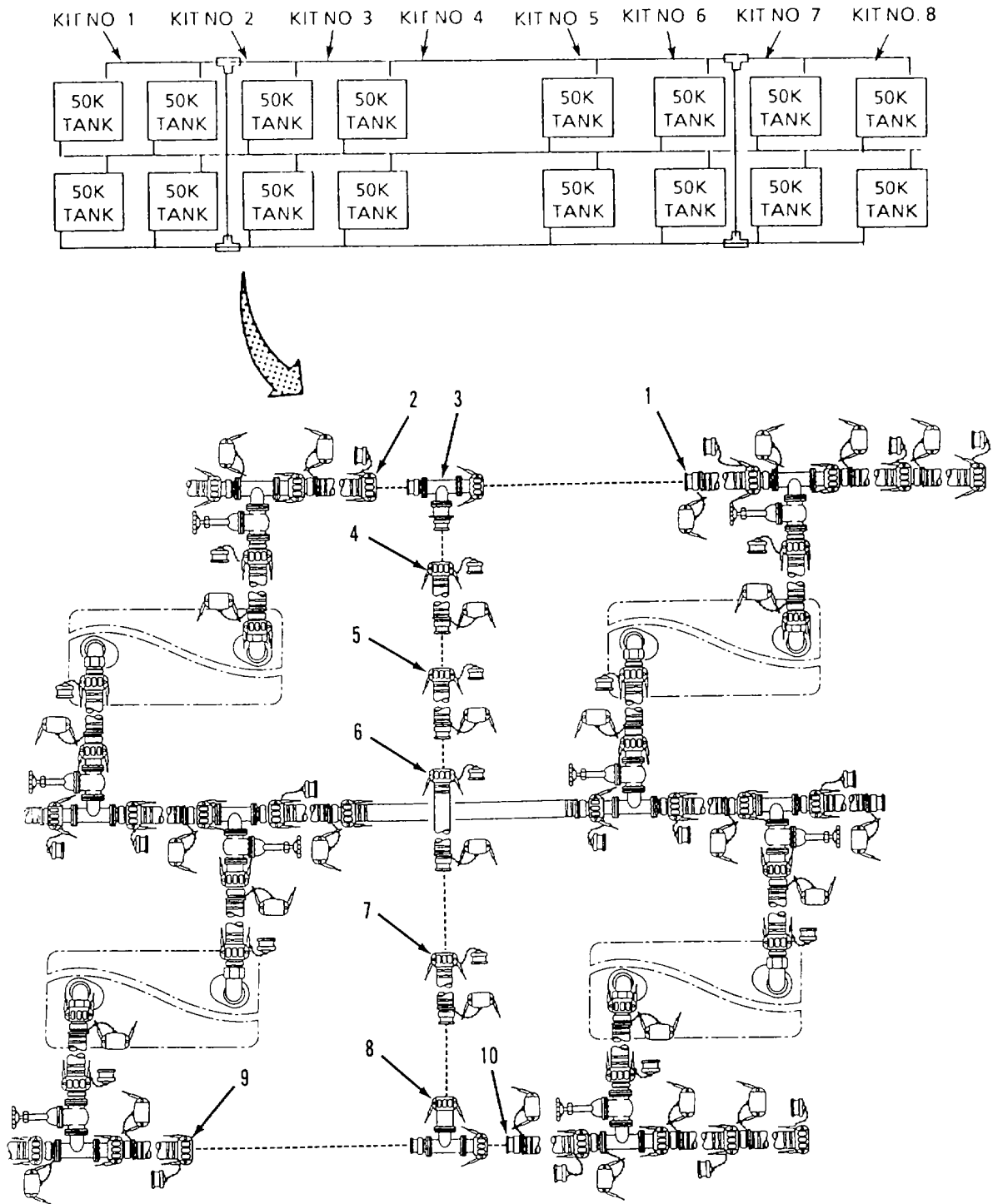

Figure 2-35. Interconnection Kit Disassembly (Sheet 1 of 2).

2-15. PREPARATION FOR MOVEMENT - cont.

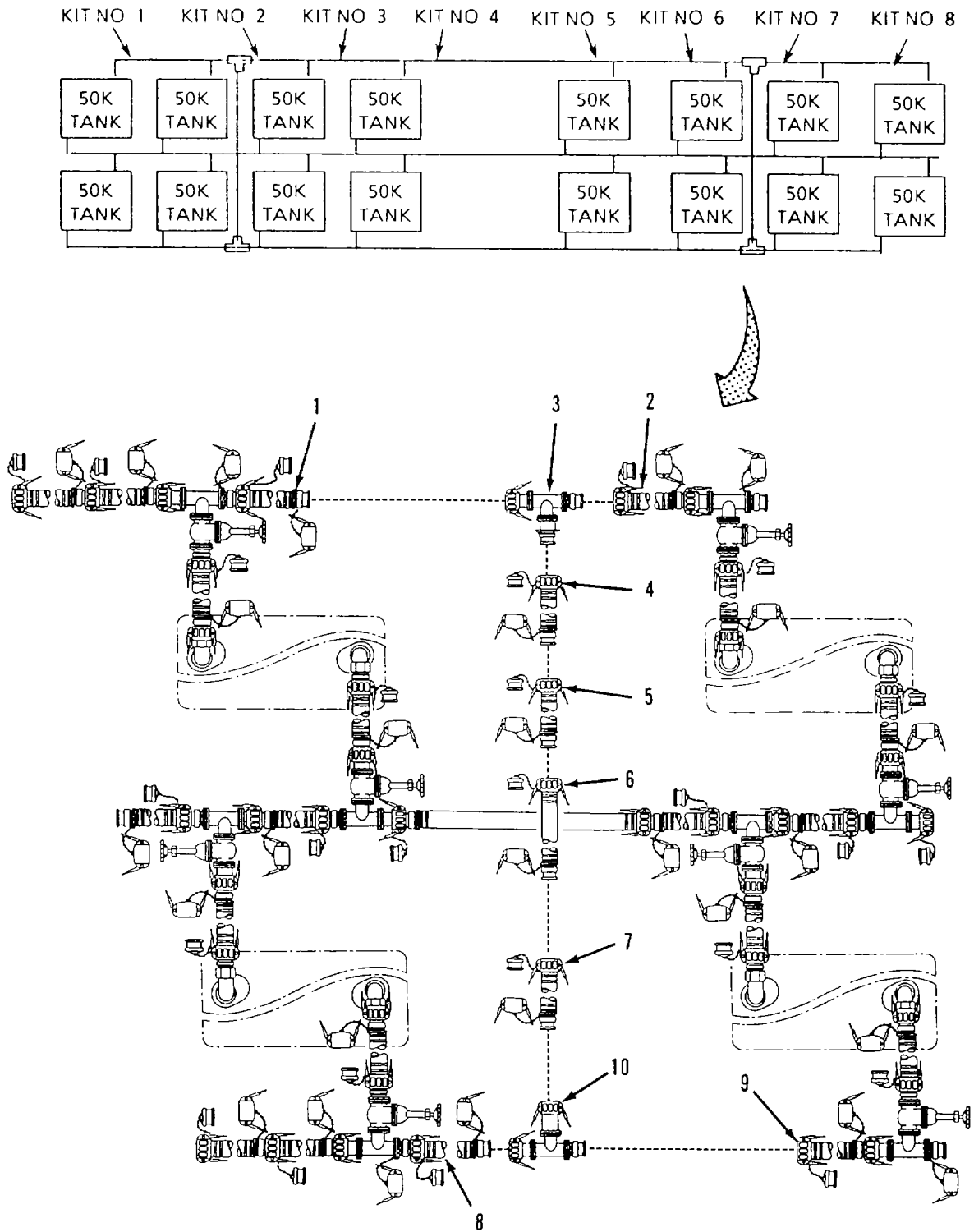

Figure 2-35. Interconnection Kit Disassembly (Sheet 2 of 2)

2-15. PREPARATION FOR MOVEMENT - cont.

- I. Disassemble Dual Tank Connection Kit Assembly. Each connection kit has been assigned a kit number. Components in kits 5 through 8 are positioned differently (opposite) kits 1 through 4 to allow interconnection of all kits at the 350 gpm pump connection kit tees. Refer to figure 2-36, sheet 1, to disassemble kits 1 through 4. Refer to sheet 2 to disassemble kits 5 through 8.

WARNING

To prevent contamination of water system components, keep dirt, mud, sand, and debris from entering open couplings during disassembly. Make sure protective caps and plugs are installed after components are disassembled.

Disassemble Kit No. 1, 2, 3, and 4. Refer from figure 2-36, sheet 1.

- (1) Disconnect 20 foot discharge hose (17) and 10 foot discharge hose (18) from tee and gate valve assembly (16).
- (2) Disconnect tee and gate valve assembly (16) from discharge hose (14).
- (3) Disconnect 20 foot discharge hose (14) from female discharge elbow (15) on water tank (19).
- (4) Disconnect 20 foot discharge hose (12) and 10 foot discharge hose (13) from tee and gate valve assembly (11).
- (5) Disconnect tee and gate valve assembly (11) from discharge hose (9).
- (6) Disconnect 20 foot discharge hose (9) from female discharge elbow (10) on water tank (20).
- (7) Disconnect 10 foot suction hose (8) from tee and gate valve assembly (5).
- (8) Disconnect 20 foot suction hose (7) between tee and gate valve assemblies (5 and 6).
- (9) Disconnect tee and gate valve assembly (6) from suction hose (3).
- (10) Disconnect tee and gate valve assembly (5) from suction hose (1).
- (11) Disconnect 20 foot suction hose (3) from male discharge elbow (4) on water tank (20).
- (12) Disconnect 20 foot suction hose (1) from male discharge elbow (2) on water tank (19).

Disassemble Kit No 5, 6, 7, and 8 Refer to figure 2-36, sheet 2.

- (13) Repeat steps (1) through (12) for kits 5, 6, 7, and 8.
- (14) Drain and allow components to dry.
- (15) Install caps and plugs on component couplings (para 2-10c).
- (16) Roll up all discharge hoses and secure with tape.
- (17) Prepare all 50K collapsible fabric tanks for movement. Refer to the applicable TM.

2-15. PREPARATION FOR MOVEMENT - cont.

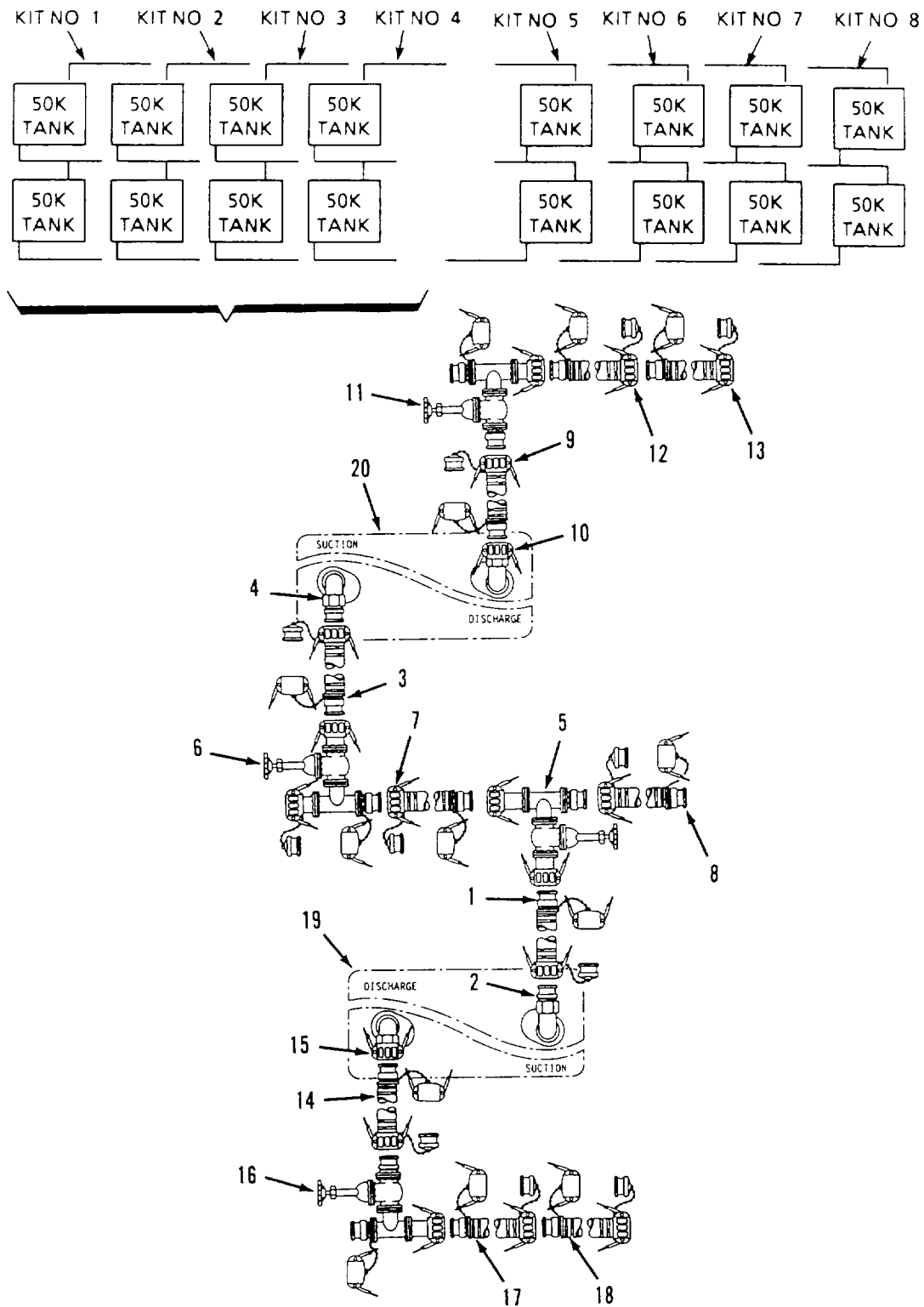

Figure 2-36. Dual link Connection Kit Disassembly (Sheet 1 of 2).

2-15. PREPARATION FOR MOVEMENT - cont.

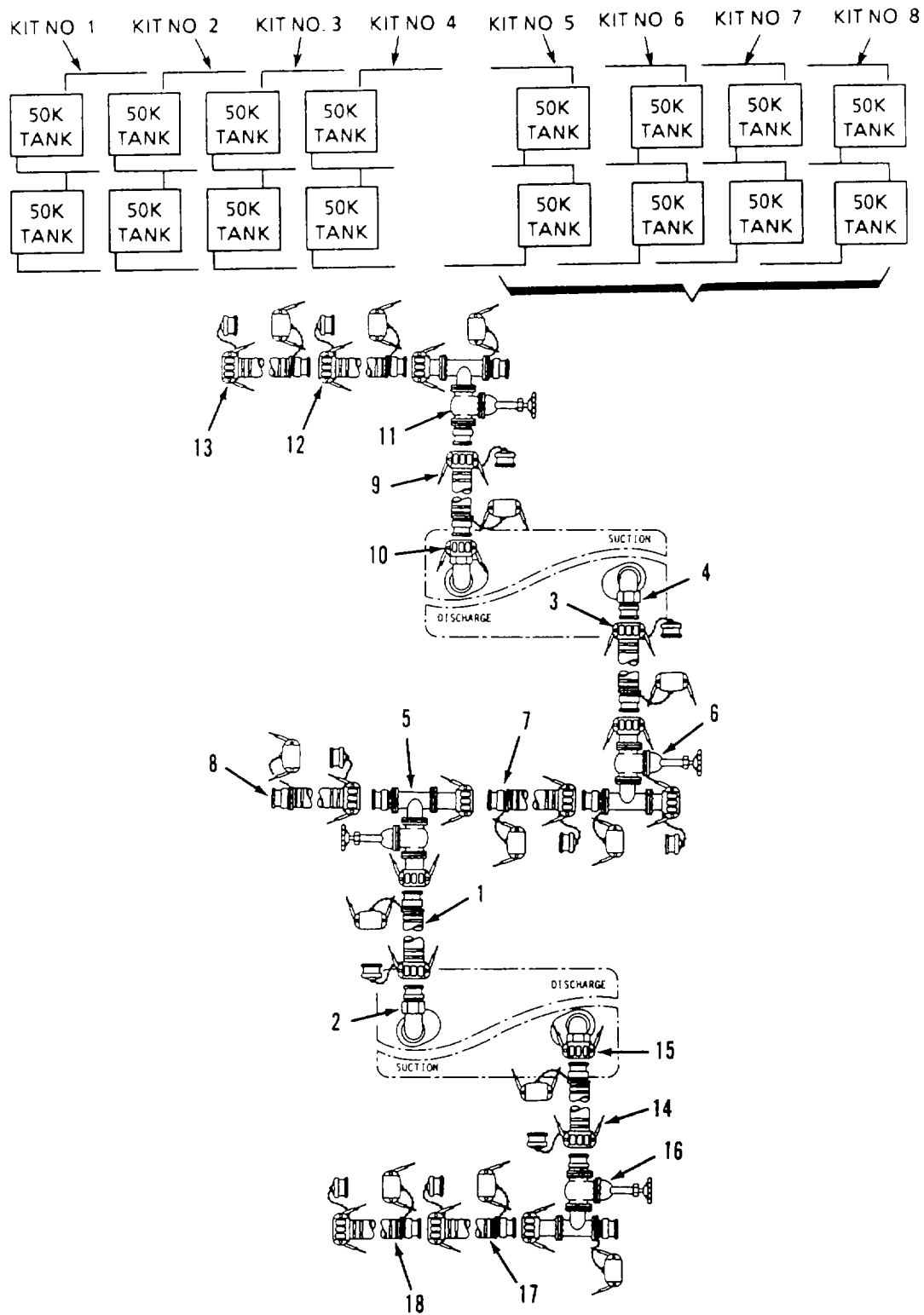

Figure 2-36. Dual Tank Connection Kit Disassembly (Sheet 2 of 2).

2-15. PREPARATION FOR MOVEMENT - cont.m. Packing.

- (1) Open twelve tricon containers. Refer to the applicable TM.
- (2) Pack water system components into tricons. If possible, keep similar components stowed together. For example, pack all 4-inch discharge hoses together, then all the 4-inch gate valves, 2-inch discharge hoses and so on until all components are stowed.
- (3) Pack hypochlorination units into tricons.
- (4) Pack 125 GPM pumps into tricons.
- (5) Pack 350 GPM pumps into tricons.
- (6) Close twelve tricon containers Refer to 'IM55-8145-200-13&P.

Section IV. OPERATION UNDER UNUSUAL CONDITIONS**2-16. OPERATION IN EXTREME COLD (BELOW 32° F (0°C)).**

- a. When the air temperature is expected to be 32°F (0°C) or below, set up the water system using the minimum number of components required to accomplish your mission.
- b. Observe the following precautions when operating the water system in extreme cold:
 - (1) Wear arctic mittens and rubber gloves when handling hardware. Bare hands can freeze to metal components. Change mittens if they get wet.
 - (2) Take advantage of existing shelter and windbreaks during system installation.
 - (3) Erect tents or shelters for protection. The collapsible tanks must be installed inside a tent or other shelter when temperature falls below freezing. Fuel, coal or wood burning heaters or other heating devices may be installed inside the erected tents to protect the equipment and prevent freezing of water.
 - (4) Do not operate heater in fuel vapor areas or areas lacking adequate ventilation. Inhalation of fumes will result in serious illness or death.
 - (5) Avoid unnecessary folding, unfolding or rolling of tank in freezing temperatures. Cracks can develop in tank fabric.
 - (6) Remove snow, sleet or ice from water tanks. Be careful to prevent cracking of tank fabric.
 - (7) Turn valve control handles slowly during cold weather. Internal seals may have become stiff and brittle.
 - (8) Remove snow, sleet or ice from quick disconnect couplings before making connections.
 - (9) Recirculate water between collapsible fabric tanks to help prevent freezing.
 - (10) When not in use, store water hoses and tanks in a heated area to avoid freezing. If frozen, disconnect hoses and move them to a heated area until they thaw.
 - (11) Refer to the applicable TM for operating the 350 GPM pump in extreme cold.
 - (12) Refer to the applicable TM for operating the 125 GPM pump in extreme cold.
 - (13) Refer to the applicable TM for operating the hypochlorination in extreme cold.
 - (14) Refer to the applicable TM for operating the collapsible fabric tanks in extreme cold.
 - (15) Monitor water system during operation for split, clogged or frozen hoses.

2-16. OPERATION IN EXTREME COLD (BELOW 32° F (0° C)).**CAUTION**

To prevent damage to the equipment, all hoses must be disconnected from the water pumps, hypochlorination units and collapsible tanks. Pumps, tanks, and hoses must be drained quickly. All control valves must be opened and all equipment inspected to assure complete drainage.

- c. If equipment is shut down during cold weather (temperature falls below 32°F (0°C), perform the following steps to ensure water is drained from collapsible tanks, hoses, valves, pumps and connections.
- (1) Open all water pump control valves (V1 through V8), water tank control valves (TB1A through TB16B) and connection kit control valves (V9A through V23) (figure 2-24).
 - (2) Open all dispensing nozzles.
 - (3) Allow water to drain from hoses and couplings.
 - (4) Drain collapsible water tanks. Refer to the applicable TM.
 - (5) Drain 125 gpm water pumps. Refer to the applicable TM.
 - (6) Drain 350 gpm water pumps. Refer to the applicable TM.
 - (7) Disconnect and drain hypochlorination units. Refer to the applicable TM.

2-17. OPERATION IN EXTREME HEAT.

Observe the following precautions when operating the water system in extreme heat:

- (1) Set up collapsible tanks, water pumps and hypochlorination units in shaded area. If shade is not available, protect water tanks from direct sunlight by constructing sun blocks or erecting portable shelters.
- (2) Ventilate area around water tanks. Make sure air flow can circulate freely around tanks.
- (3) Avoid unnecessary folding, unfolding or rolling of empty water tanks and hoses. Do not store unused tank in direct sunlight.
- (4) Refer to the applicable TM for operating the 350 GPM pump in extreme heat.
- (5) Refer to the applicable TM for operating the 125 GPM pump in extreme heat.
- (6) Refer to the applicable TM for operating the hypochlorination unit in extreme heat.
- (7) Refer to the applicable TNM for operating the water tanks under in extreme heat.

2-17. OPERATION IN EXTREME HEAT. - cont.

- (8) Monitor water supply for excessive bacterial and algae growth. Adjust output of hypochlorination units as directed by medical personnel. Refer to the applicable TM.

2-18. OPERATIONS IN DUSTY OR SANDY AREAS.

Observe the following precautions when operating the water system in dusty or sandy areas:

- (1) Keep dust caps in place on fittings and couplings until ready for use.
- (2) Carefully inspect coupling gaskets before connecting fittings. Remove all dirt, sand and debris before making connections.
- (3) Refer to the applicable TM for operating the 350 GPM pump in dusty or sandy areas.
- (4) Refer to the applicable TM for operating the 125 GPM pump in dusty or sandy areas.
- (5) Refer to the applicable TM for operating the hypochlorination unit in dusty or sandy areas.
- (6) Refer to the applicable TM for operating the water tanks under in dusty or sandy areas.
- (7) Following operation in dusty or sandy areas, rinse all components with clean, fresh water to remove sand, dust and grit. Direct special attention to quick disconnect coupling gaskets and locking arms.

2-19. OPERATION IN SALT WATER AREAS.

Operation in salt water areas accelerates corrosion on bare metal surfaces. Observe the following precautions when operating the water system this environment.

- (1) Carefully inspect water system components during installation. If bare metal is found, notify unit maintenance to preserve or paint the metal as required.
- (2) Following operation in salt water areas, rinse components with clean fresh water to remove salt spray and/or deposits.
- (3) Refer to the applicable TM for operation of the 350 gpm pump in salt water areas.
- (4) Refer to the applicable TM for operation of the 125 gpm pump in salt water areas.
- (5) Refer to the applicable TM for operation of the hypochlorination unit in salt water areas.

2-20. EMERGENCY PROCEDURES.

The 800K Water Storage and Distribution System provides sufficient water storage and pumping capacity to allow isolation and redirection of water flow around failed components without a severe drop in operational capacity

- a. 350 Gpm Pump (P1) Failure. Refer to figure 2-24.
 - (1) Shut down 350 gpm pump P1. Refer to the applicable TM.
 - (2) Close gate valves V1 and V2.
 - (3) If closed, open gate valves V3 and V4.
 - (4) Start and operate 125 gpm pump P2. Refer to the applicable TM.
 - (5) Continue to operate water system using 125 gpm pump.
- b. 125 Gpm Pump (P2) Failure. Refer to figure 2-24.
 - (1) Shut down 125 gpm pump P2. Refer to the applicable TM.
 - (2) Close gate valves V3 and V4.
 - (3) If closed, open gate valves V1 and V2.
 - (4) Start and operate 350 gpm pump P1. Refer to the applicable TM.
 - (5) Continue to operate water system using 350 gpm pump.
- c. Component Failure . Refer to figure 2-24. In the event of a hose, coupling, tank or valve rupture, the failed component must be isolated as soon as possible to stop the loss of water.

WARNING

To prevent injury to personnel, do not attempt to grab whipping hose.

- (1) If ruptured hose is whipping, shutdown all water pumps.

CAUTION

To prevent damage to the equipment, water system must be shut down if isolating failed component(s) will block water flow to or from either 350 gpm pump connection kit.

- (2) Close nearest upstream and downstream control valves to stop water flow through failed component.
- (3) If failed component is located in one of the 125 gpm pump connection kits, shutdown the 125 gpm pump and start the 350 gpm pump. Refer to the applicable TMs.
- (4) Continue operation with failed component isolated from system.

2-21. DECONTAMINATION PROCEDURES.**NOTE**

Detailed decontamination procedures can be found in: FM 3-3, FM 3-4, and FM 3-5.

- a. General. The following emergency procedures can be performed until field NBC DECON facilities are available. Assigned operators will assist the supporting NBC unit.
- b. Emergency Procedures. If NBC attack is known or suspected, mask at once and:
 - (1) Stop dispensing water.
 - (2) Reduce the risk of introducing contamination into the water system by shutting down 350 gpm pumps and 125 gpm pumps. Refer to the applicable TMs.
 - (3) Shut down hypochlorination units (refer to the applicable TM). Hypochlorite solution container is not air tight and may have been contaminated.
 - (4) Do not connect or disconnect any components from the water system. System integrity must be maintained until decontamination of equipment is complete.
 - (5) Test water for contamination using the NBC kit and provide a water sample to medical personnel before resuming operation.

CHAPTER 3

OPERATOR MAINTENANCE INSTRUCTONS

Section I	Lubrication Instructions	3-1
Section II	Operator Troubleshooting.....	3-1
3-1	Introduction	3-1
3-2	Malfunction Index.....	3-2
3-3	Troubleshooting Table.....	3-2
Section III	Operator Maintenance Procedures	3-26
3-4	Component Replacement.....	3-26
3-5	Quick Disconnect Coupling Repair	3-28

Section I. LUBRICATION INSTRUCTIONS

Lubrication of the 800K Water Storage and Distribution System is limited to the 350 gpm and 125 gpm pumps. Lubricate this equipment in accordance with the applicable technical manual.

Refer to the applicable TM for lubrication requirements on the 350 gpm pumps.

Refer to the applicable TM for lubrication requirements on the 125 gpm pumps

Section II. OPERATOR TROUBLESHOOTING

3-1. INTRODUCTION.

- a. The troubleshooting table lists the common malfunctions which you may find during operation of the water system. You should perform the tests, inspections and corrective actions in the order they appear in the table.
- b. This table cannot list all the malfunctions that may occur, all the tests or inspections needed to find the fault, or all the corrective actions needed to correct the fault. If the equipment malfunction is not listed or actions listed do not correct the fault, notify your supervisor.
- c. Refer to the applicable TM for troubleshooting malfunctions on the 350 gpm pumps.
- d. Refer to the applicable TM for troubleshooting malfunctions on the 125 gpm pumps
- e. Refer to the applicable T'M for troubleshooting malfunctions on the hypochlorination units.
- f. Refer to the applicable TM for troubleshooting malfunctions on the 50K collapsible fabric tanks.

3-2. MALFUNCTION INDEX

Malfunction	Page
1 No water Flow to loading Stations	3-3
2 Low Water Pressure at Loading Stations.....	3-4
3 Discharge or Suction Hose Leaks	3-6
4 Gate Valve Assembly (2-inch) Leaks	3-7
5 Gate Valve Assembly (2-inch) Stuck or Jammed.....	3-8
6 Tee Assembly (All) Leaks.....	3-9
7 Distribution Nozzle (1-Inch) Leaks.....	3-10
8 Distribution Nozzle (1-Inch) Stuck Open or Closed	3-11
9 Water Pressure Regulator Teaks.....	3-12
10 Water Pressure Regulator Pressure Not Correct.....	3-13
11 Distribution Nozzle (1-1/2 Inch) Leaks	3-14
12 Distribution Nozzle (1-1/2 Inch) Stuck Open or Closed.....	3-15
13 Butterfly Valve Assembly Leaks	3-16
14 Butterfly Valve Assembly Stuck Open or Closed	3-17
15 Quick Acting Valve Assembly leaks	3-18
16 Quick Acting Valve Assembly Stuck Open or Closed	3-19
17 Gate Valve (4-inch) Assembly Leaks.....	3-20
18 Gate Valve (4-inch) Assembly Stuck Open or Closed	3-21
19 Water Meter Assembly leaks.....	3-22
20 Water Meter Will Not Operate	3-23
21 Check Valve (2-inch) Leaks.....	3-24
22 Check Valve (2-inch) Stuck Open or Closed	3-25
23 Tee and Gate Valve Assembly (All) Leaks	3-25
24 Tee and Gate Valve Assembly (All) Stuck Open or Closed	3-25

3-3. TROUBLESHOOTING TABLE

Refer to table 3-1 for Operator Troubleshooting instructions.

Table 3-1. Operator Troubleshooting

WARNING

Be sure to read ALL Warnings in front of manual before troubleshooting.

MALFUNCTION 1. NO WATER FLOW TO LOADING STATIONS.

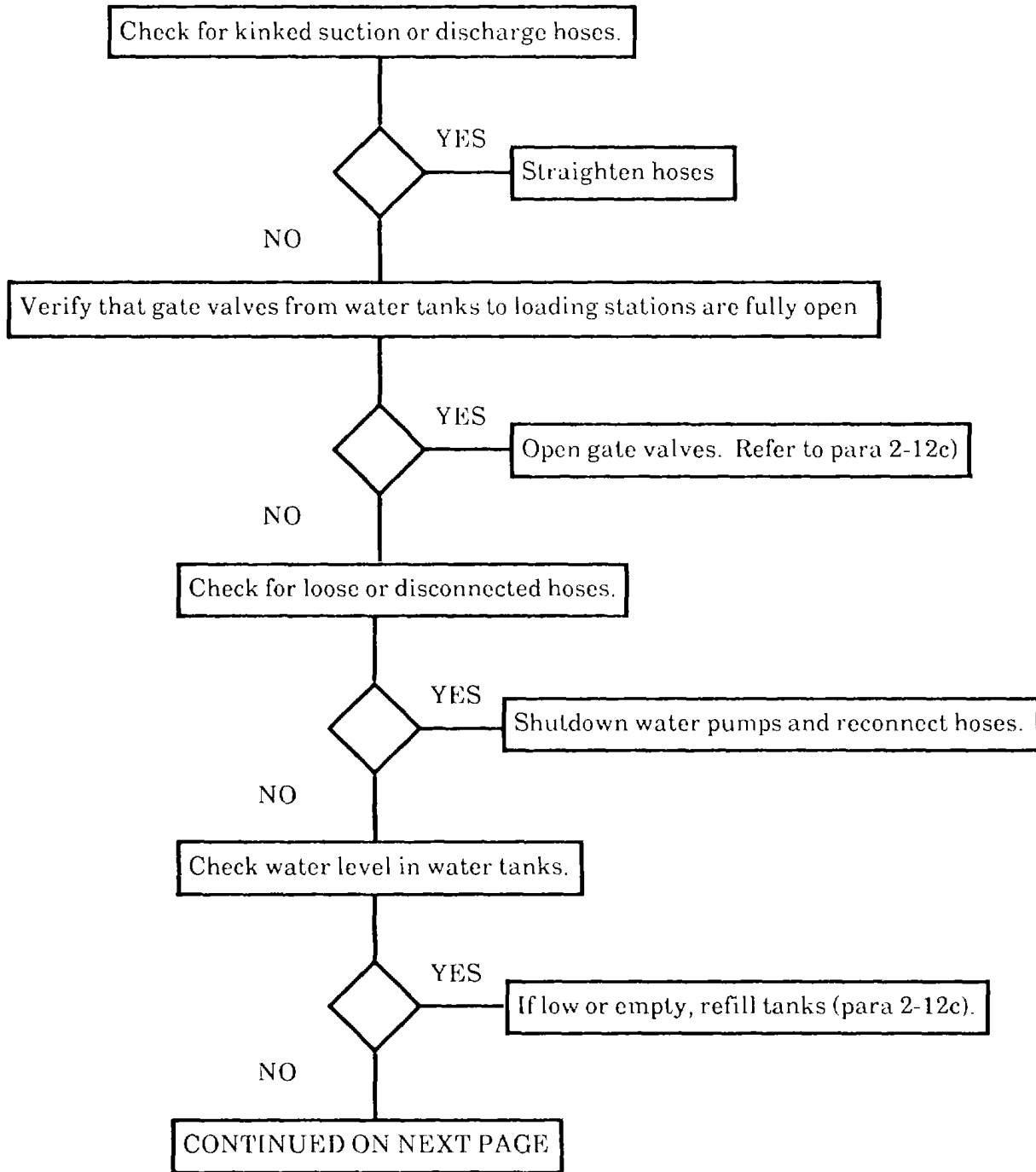
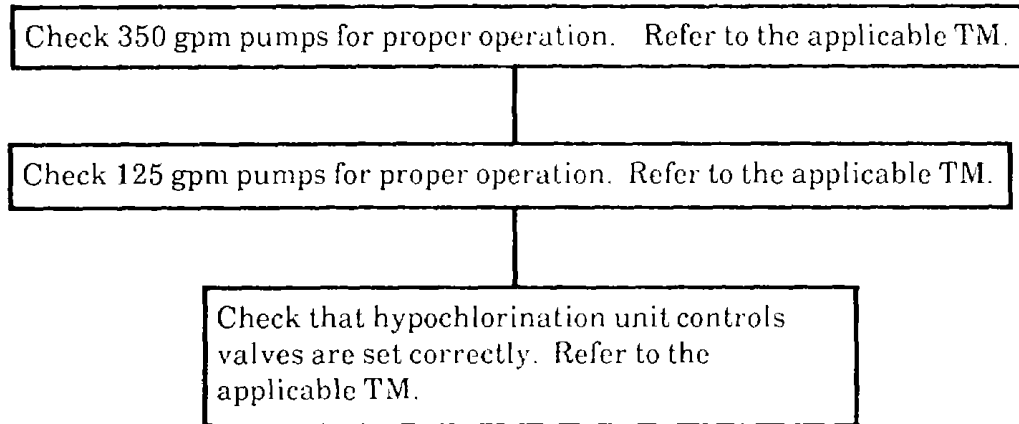

Table 3-1. Operator Troubleshooting

MALFUNCTION 1. NO WATER FLOW TO LOADING STATIONS - cont.



MALFUNCTION 2. LOW WATER PRESSURE TO LOADING STATIONS.

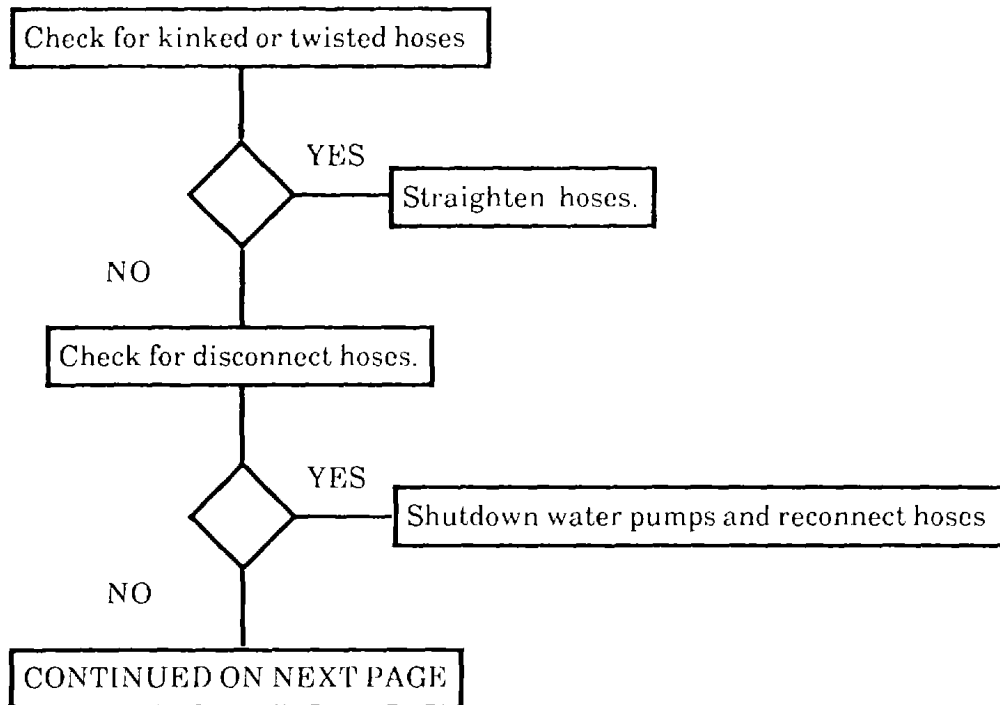

Table 3-1. Operator Troubleshooting - cont.

MALFUNCTION 2. LOW WATER PRESSURE AT LOADING STATIONS - cont.

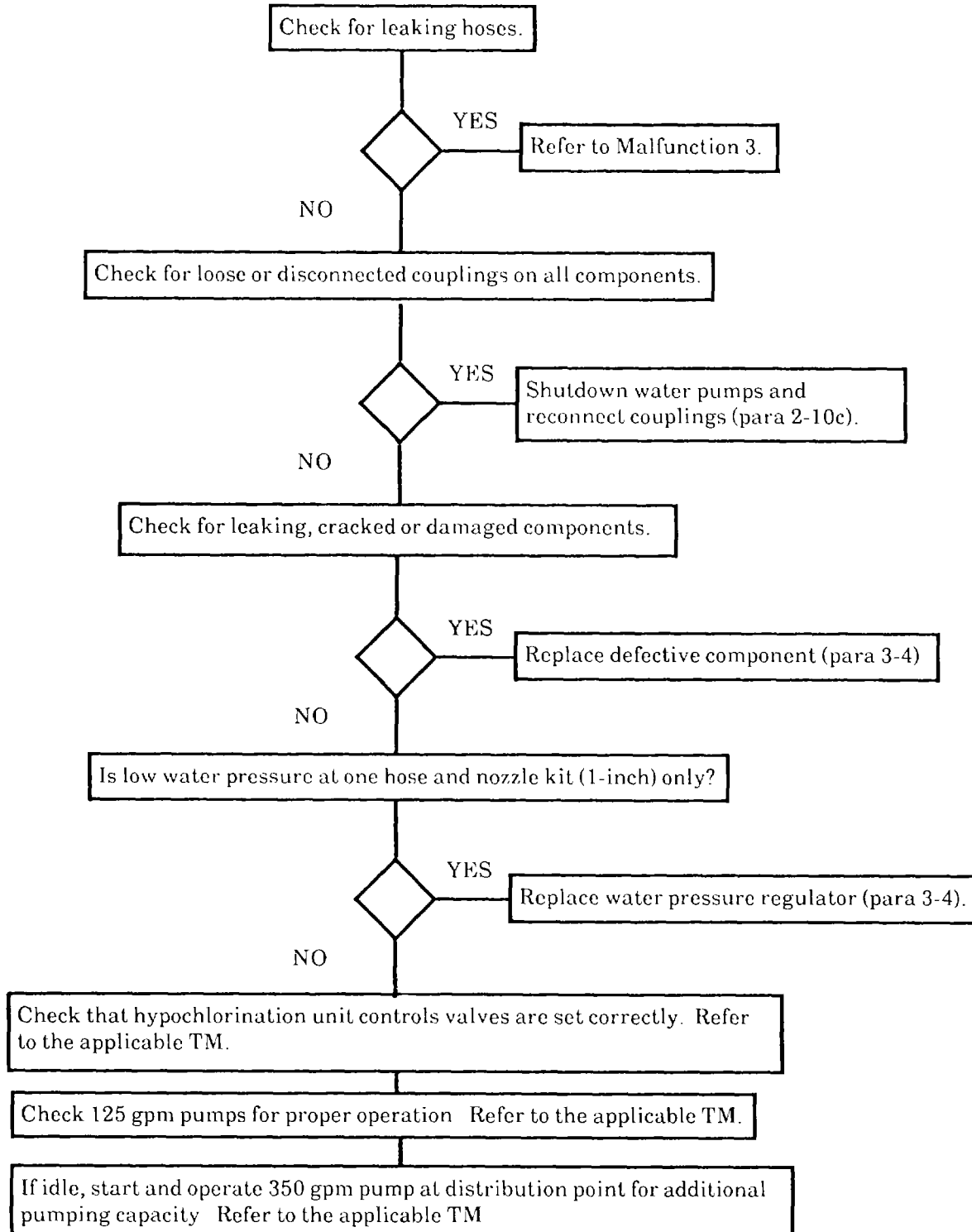

Table 3-1. Operator Troubleshooting - cont.

MALFUNCTION 3. DISCHARGE OR SUCTION HOSE LEAKS.

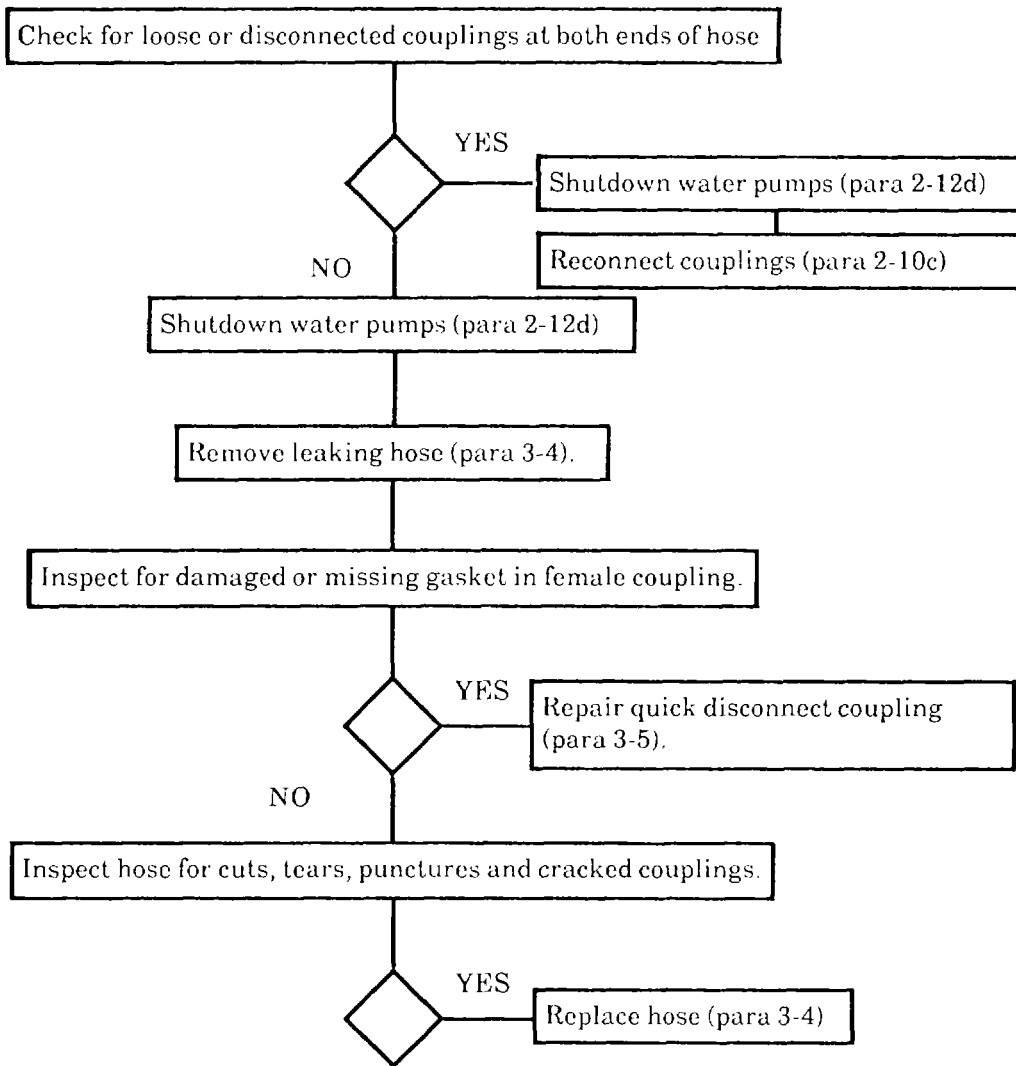

Table 3-1. Operator Troubleshooting - cont.

MALFUNCTION 4. GATE VALVE ASSEMBLY (2-INCH) LEAKS.

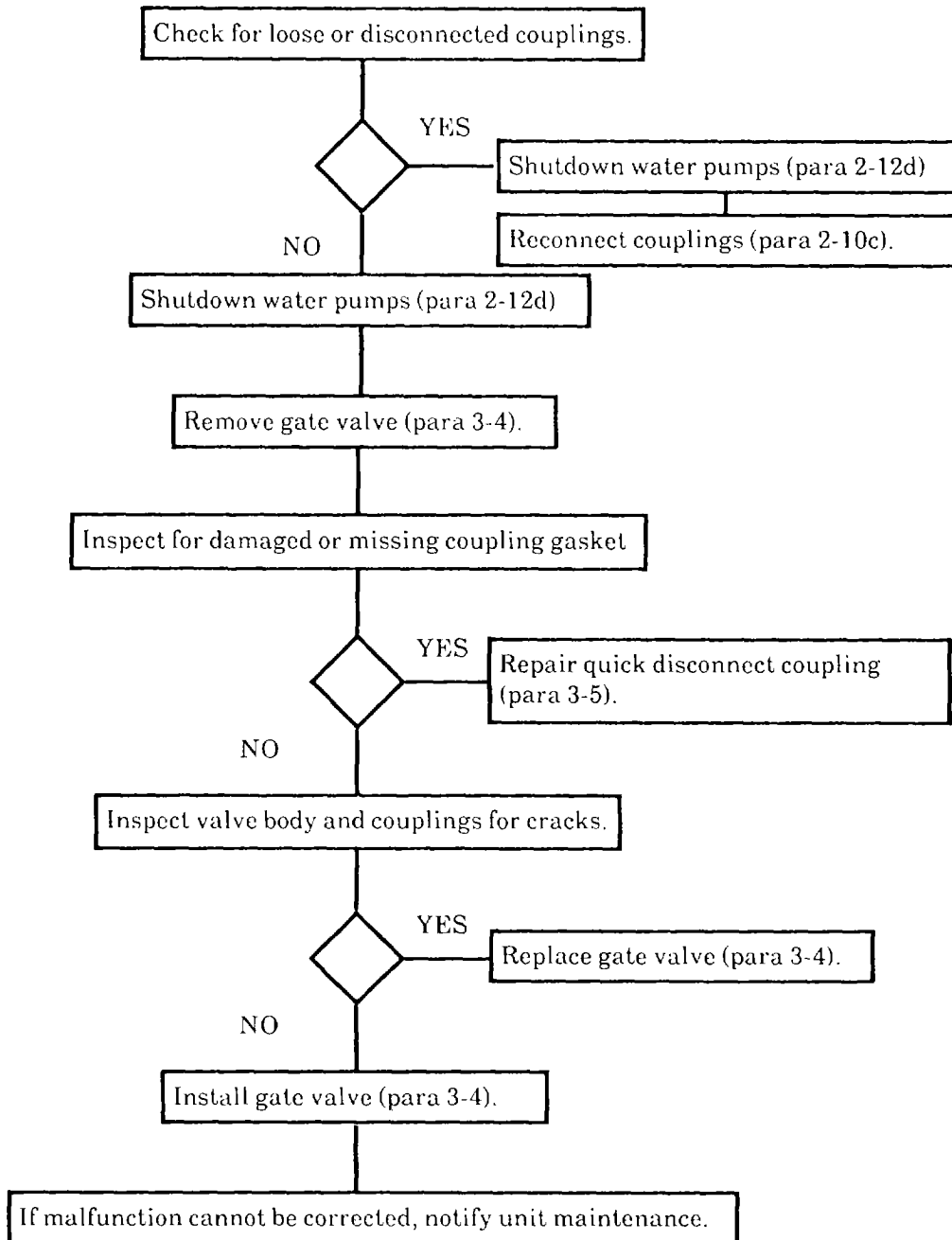

Table 3-1. Operator Troubleshooting - cont.

MALFUNCTION 5. GATE VALVE ASSEMBLY (2-INCH) STUCK OR JAMMED).

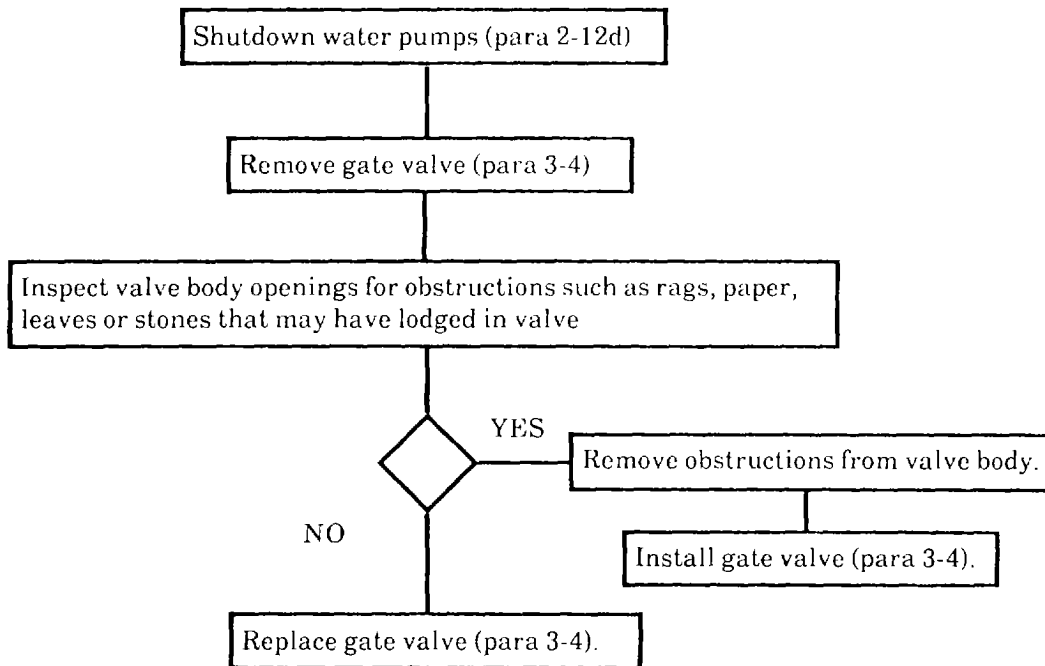

Table 3-1. Operator Troubleshooting - cont.

MALFUNCTION 6. TEE ASSEMBLY LEAKS.

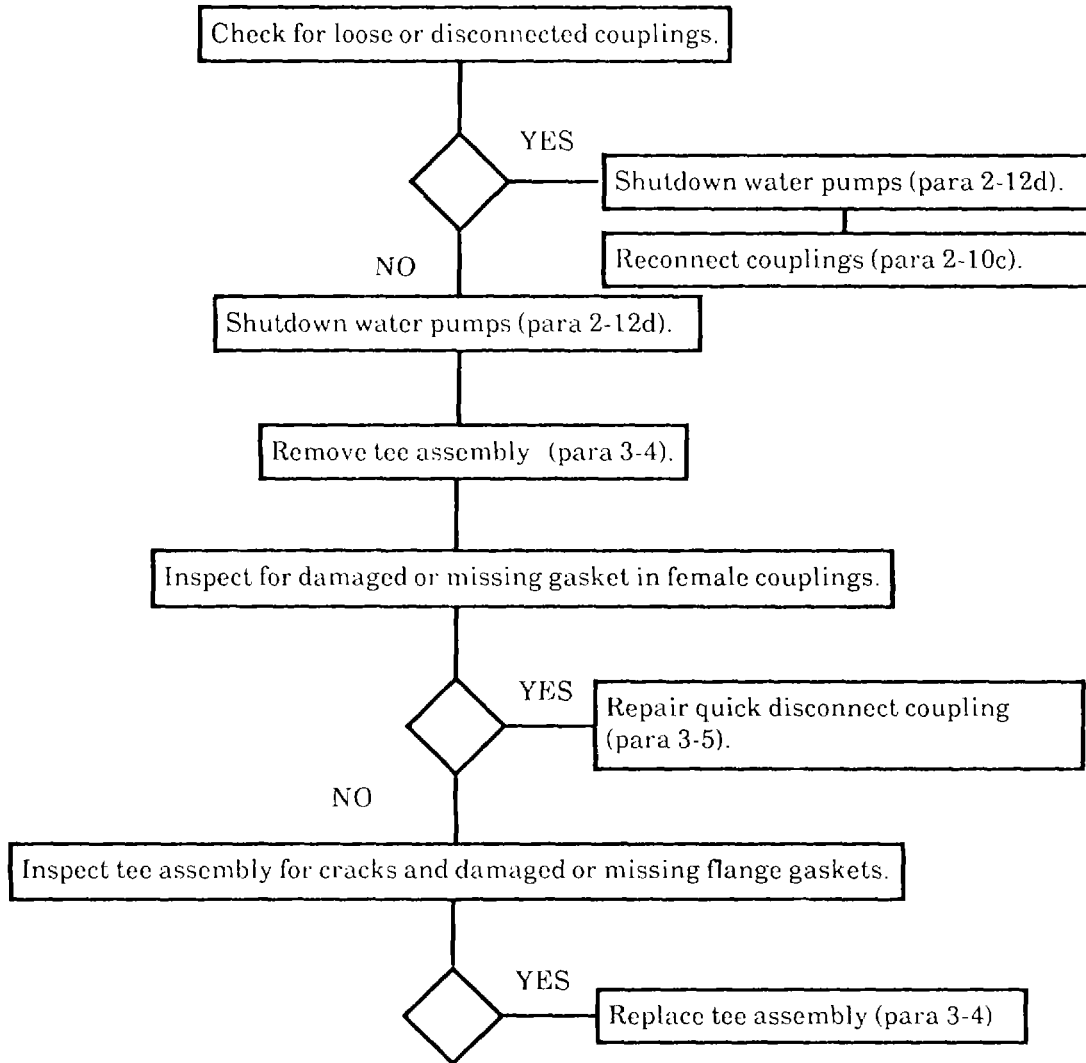

Table 3-1. Operator Troubleshooting - cont.

MALFUNCTION 7. DISTRIBUTION NOZZLE (1-INCH) LEAKS.

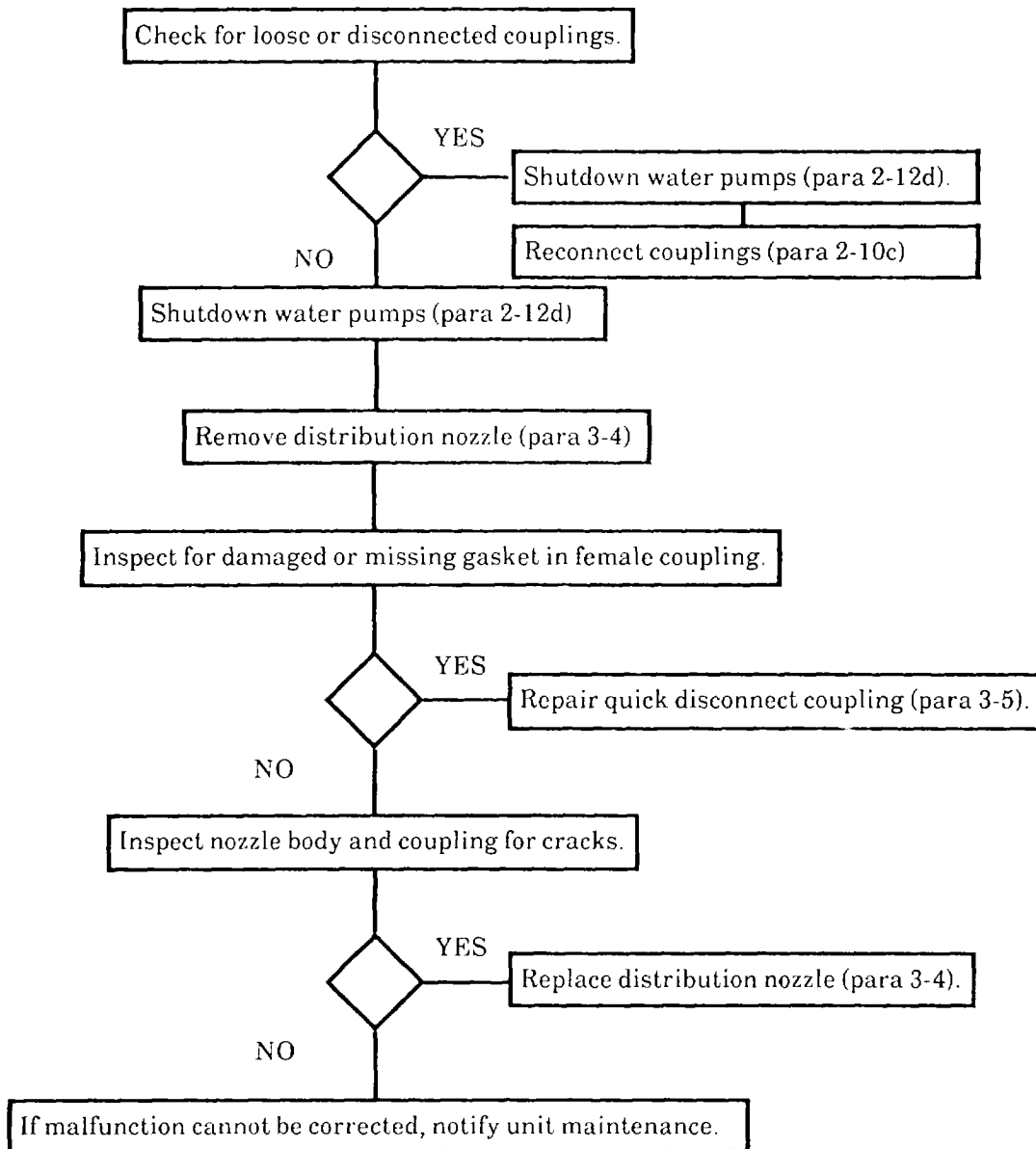

Table 3-1. Operator Troubleshooting - cont.

MALFUNCTION 8. DISTRIBUTION NOZZLE (1-INCH) STUCK OPEN OR CLOSED.

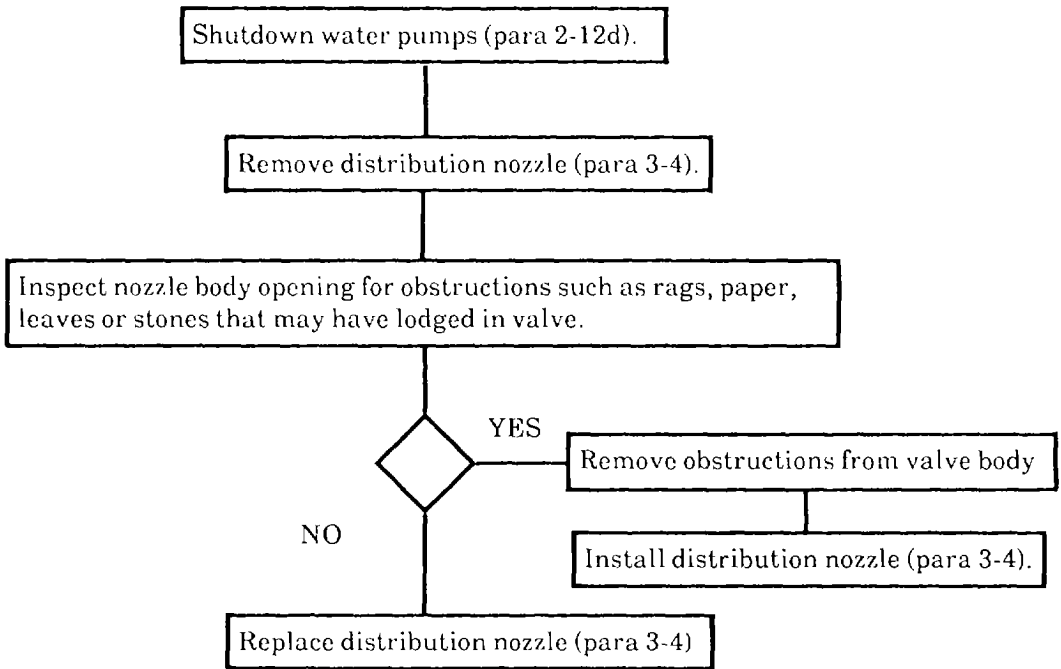

Table 3-1. Operator Troubleshooting - cont.

MALFUNCTION 9. WATER PRESSURE REGULATOR LEAKS.

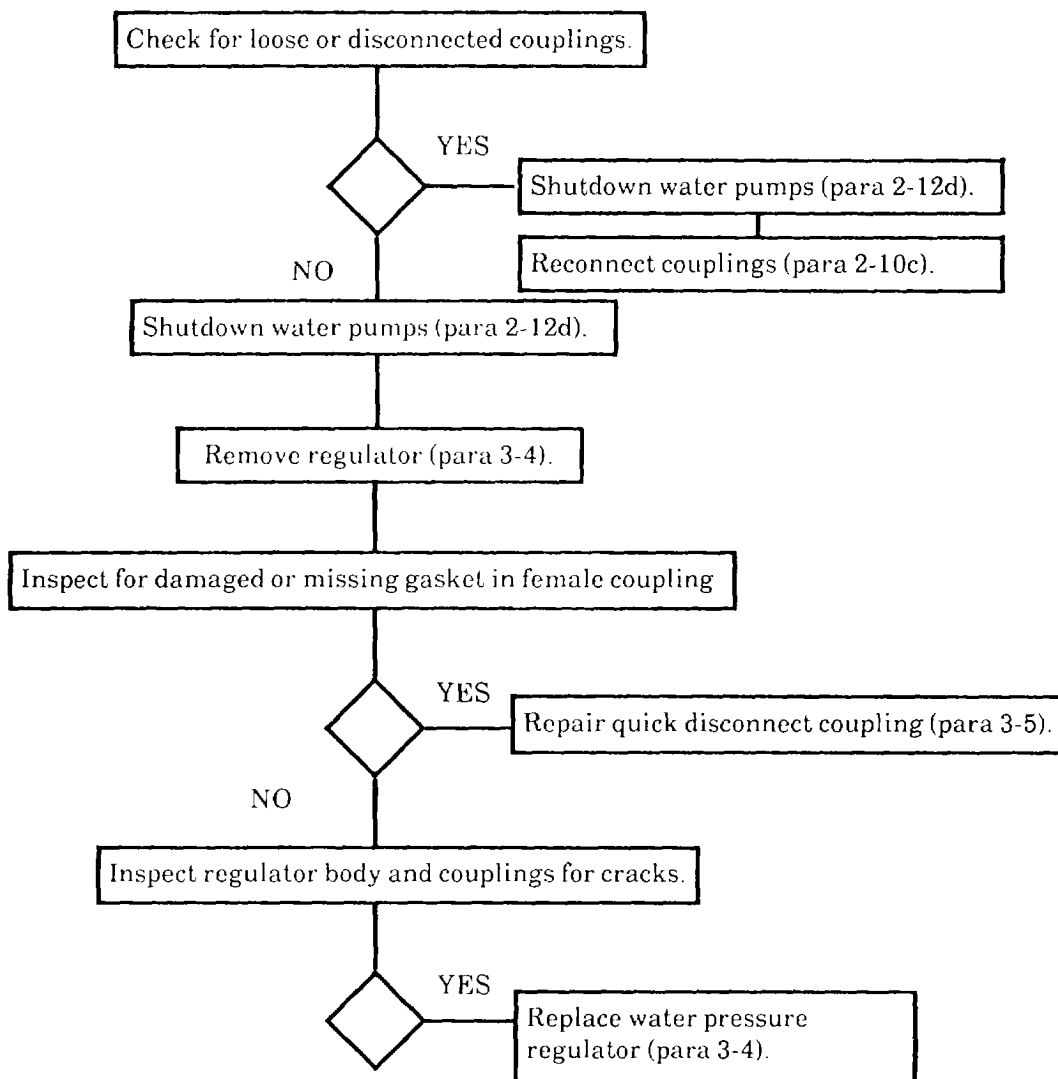

Table 3-1. Operator Troubleshooting - cont.

MALFUNCTION 10. WATER PRESSURE REGULATOR PRESSURE NOT CORRECT.

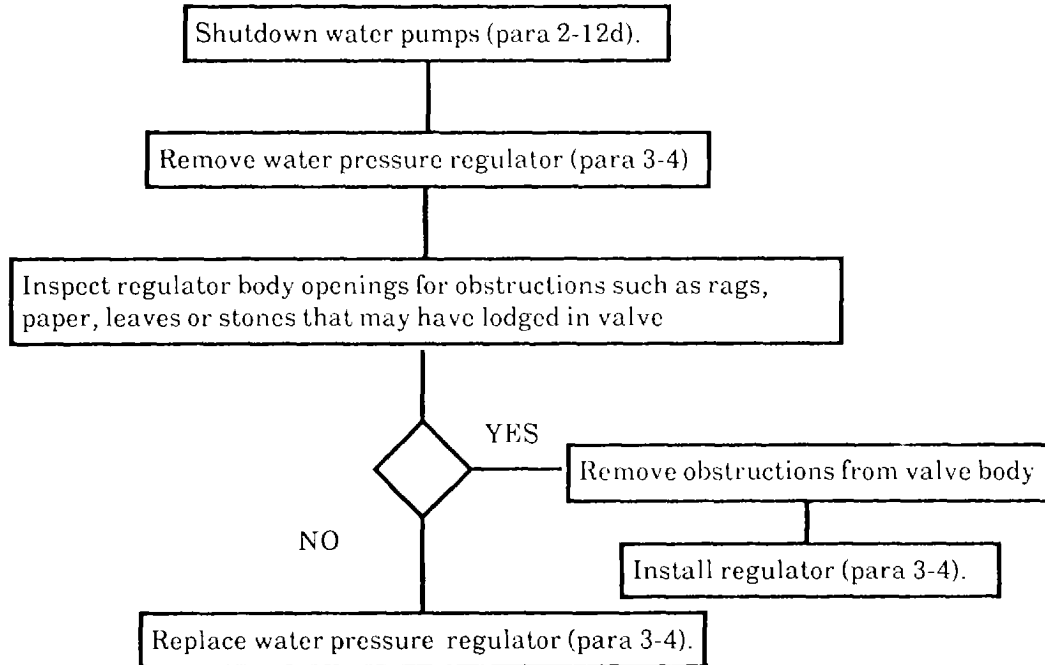

Table 3-1. Operator Troubleshooting - cont.

MALFUNCTION 11. DISTRIBUTION NOZZLE (1-1/2 INCH) LEAKS.

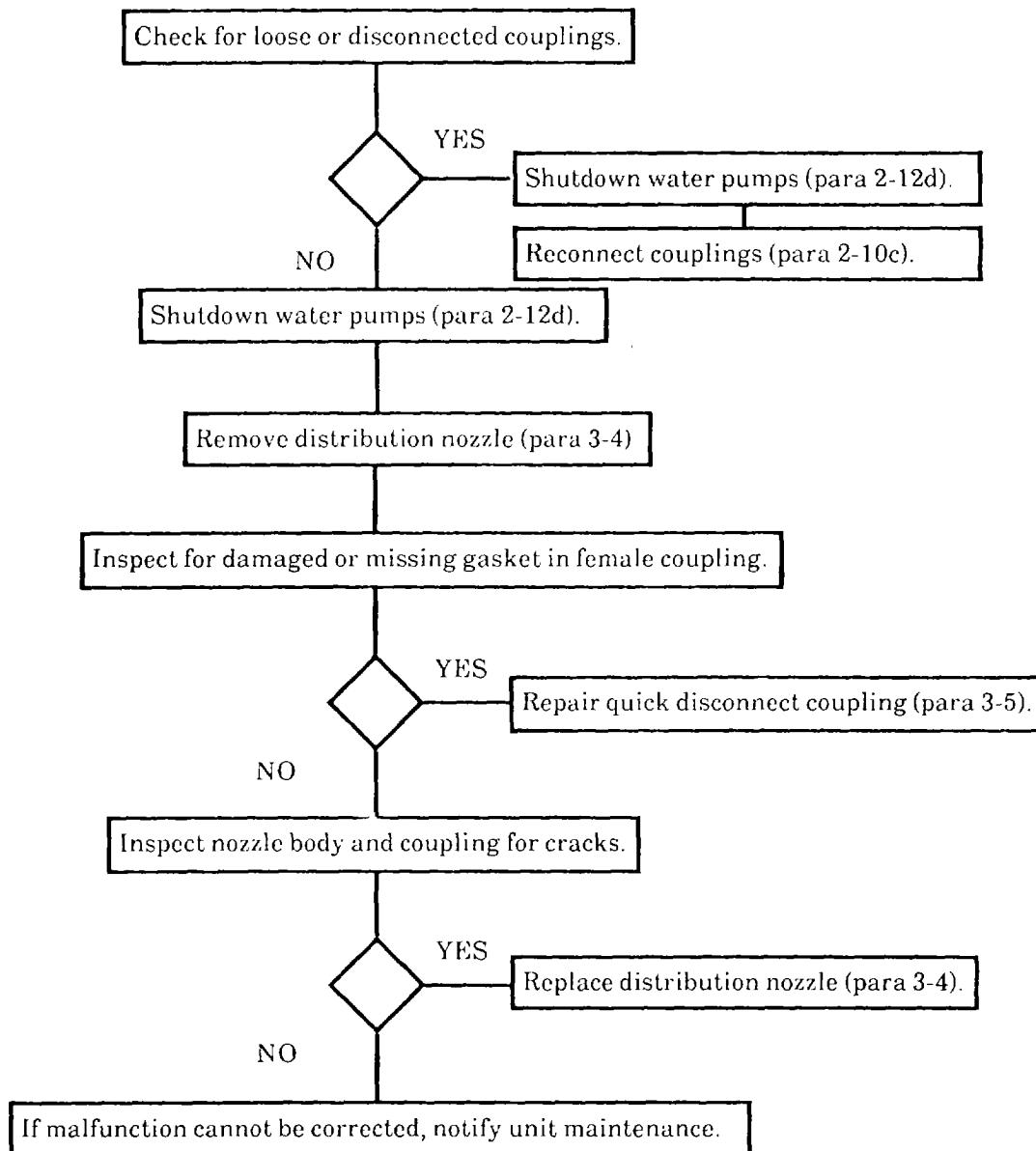

Table 3-1. Operator Troubleshooting - cont.

MALFUNCTION 12. DISTRIBUTION NOZZLE (1-1/2 INCH) STUCK OPEN OR CLOSED.

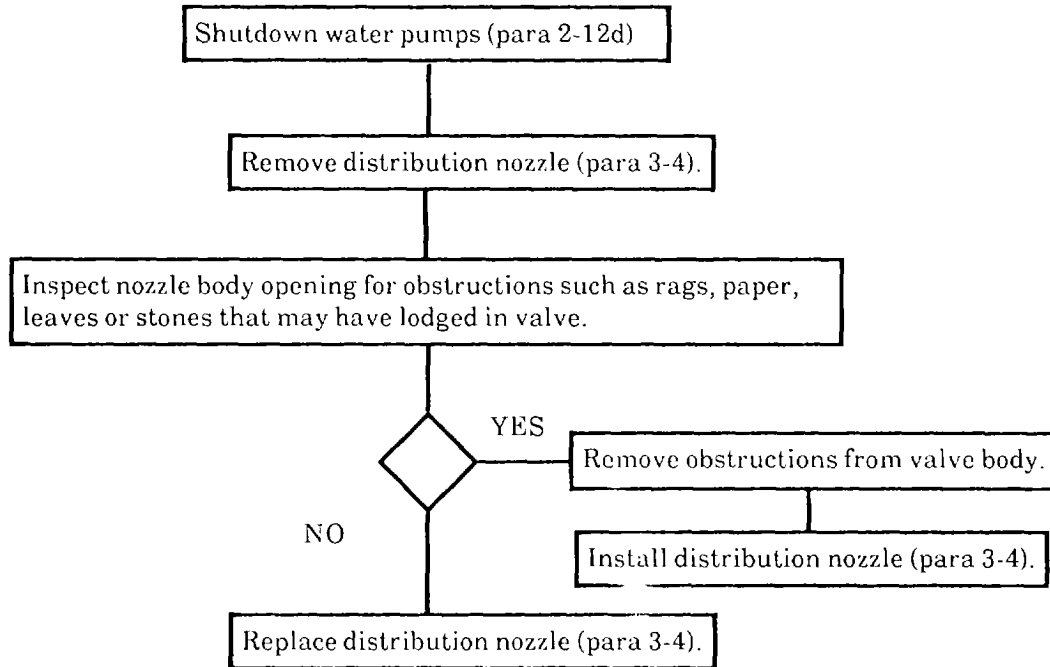

Table 3-1. Operator Troubleshooting - cont.

MALFUNCTION 13. BUTTERFLY VALVE ASSEMBLY LEAKS.

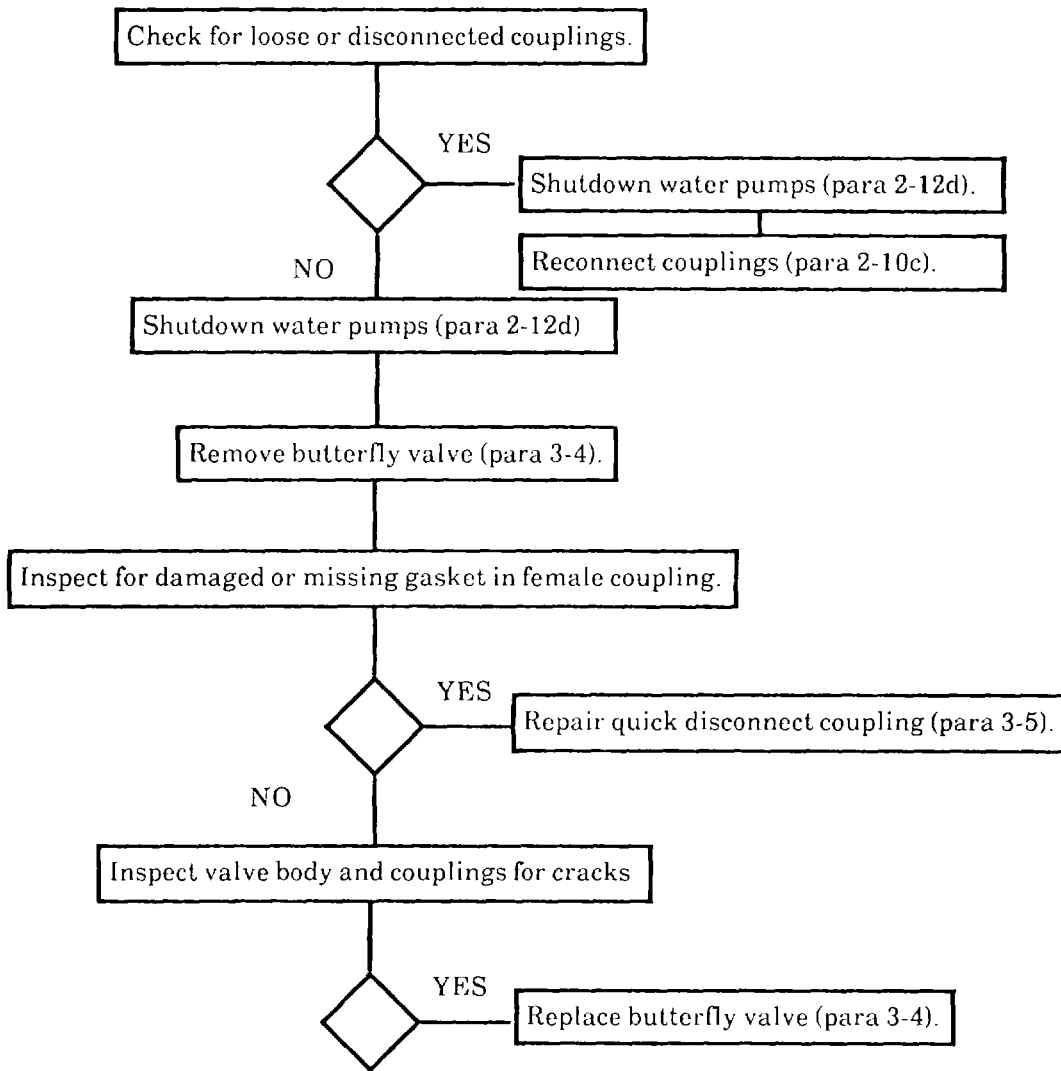

Table 3-1. Operator Troubleshooting - cont.

MALFUNCTION 14. BUTTERFLY VALVE ASSEMBLY STUCK OPEN OR CLOSED.

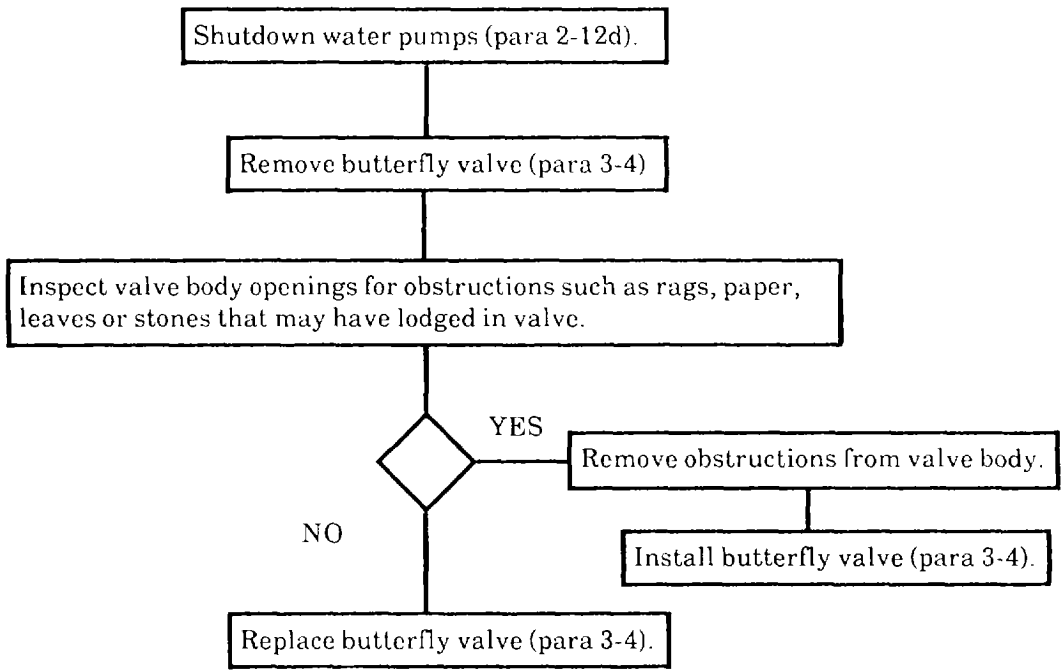

Table 3-1. Operator Troubleshooting - cont.

MALFUNCTION 15. QUICK ACTING VALVE ASSEMBLY LEAKS.

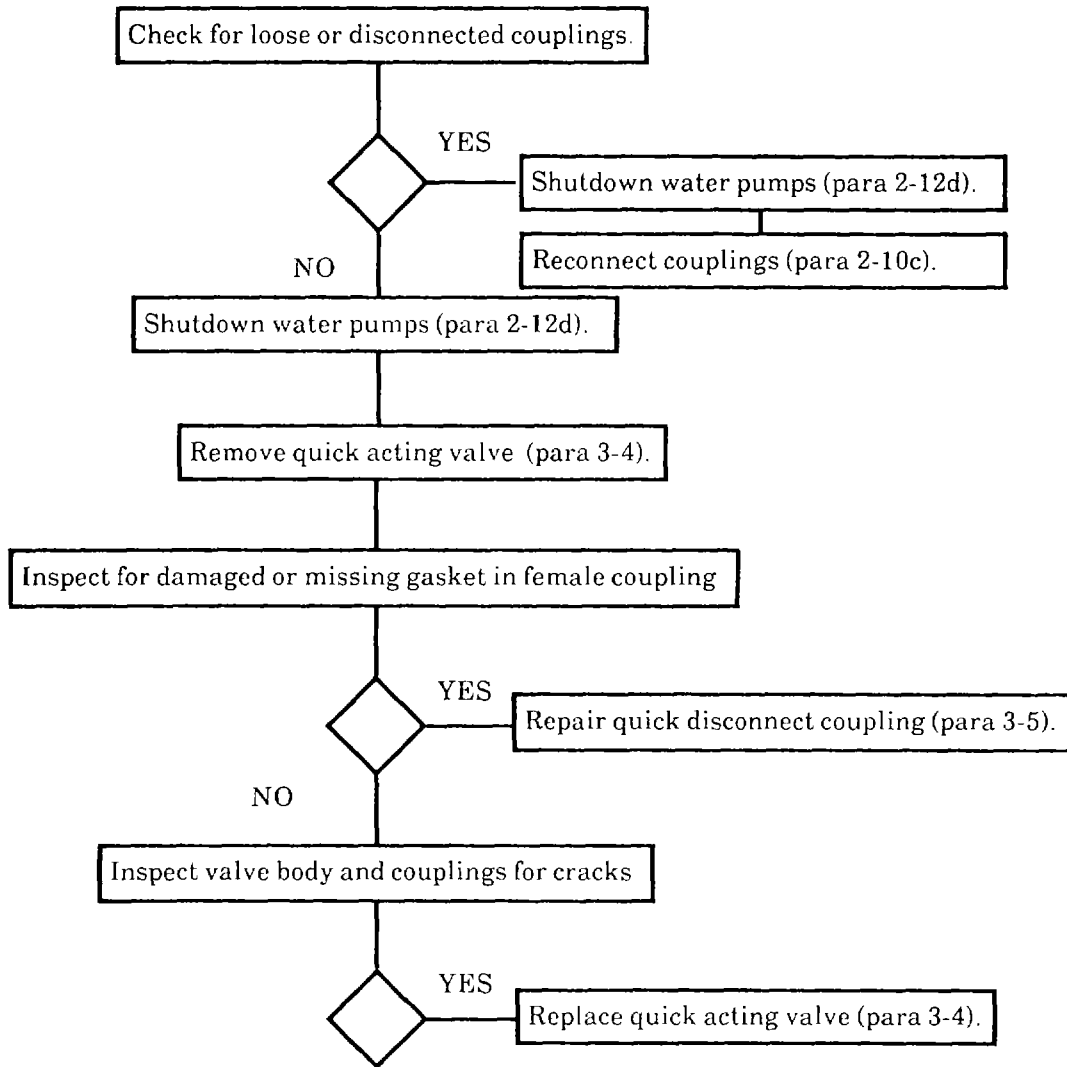

Table 3-1. Operator Troubleshooting - cont.

MALFUNCTION 16. QUICK ACTING VALVE ASSEMBLY STUCK OPEN OR CLOSED.

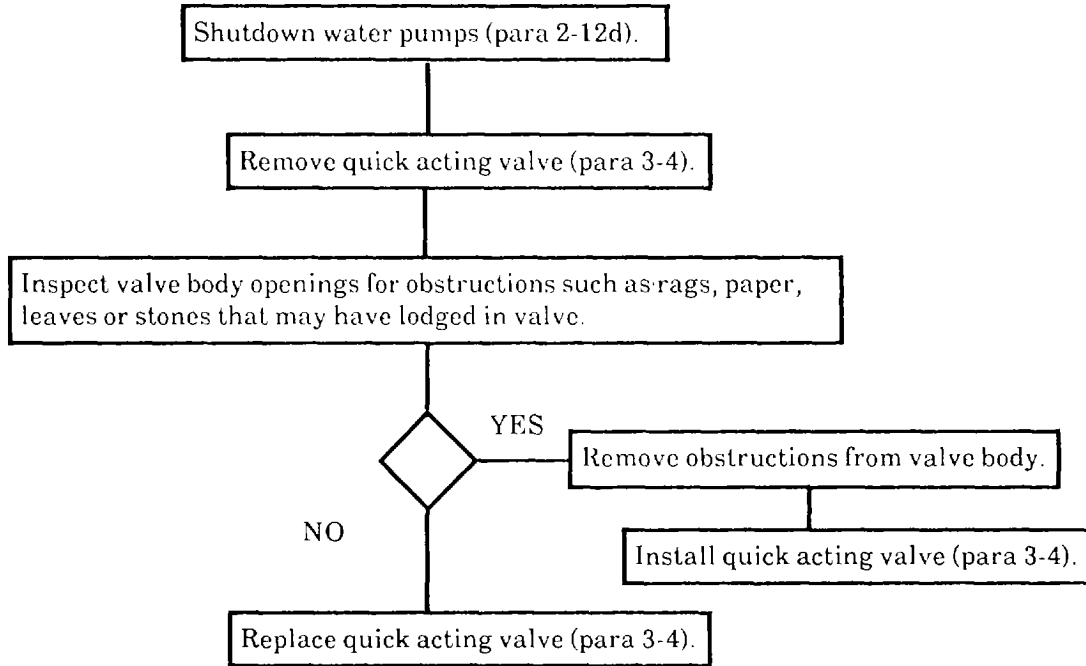

Table 3-1. Operator Troubleshooting - cont.

MALFUNCTION 17. GATE VALVE ASSEMBLY (4-INCH) LEAKS.

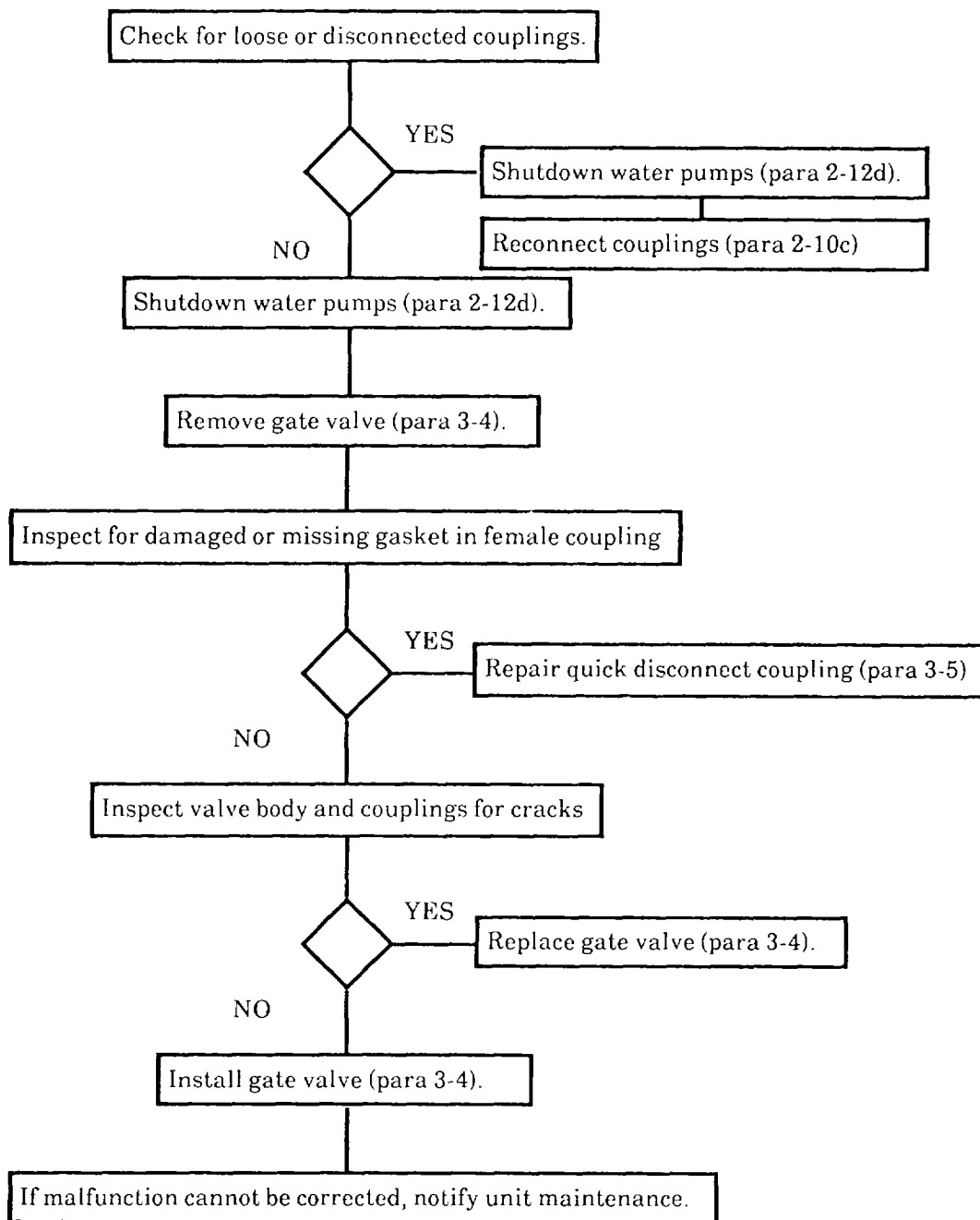

Table 3-1. Operator Troubleshooting - cont.

MALFUNCTION 18. GATE VALVE ASSEMBLY (4-INCH) STUCK OPEN OR CLOSED.

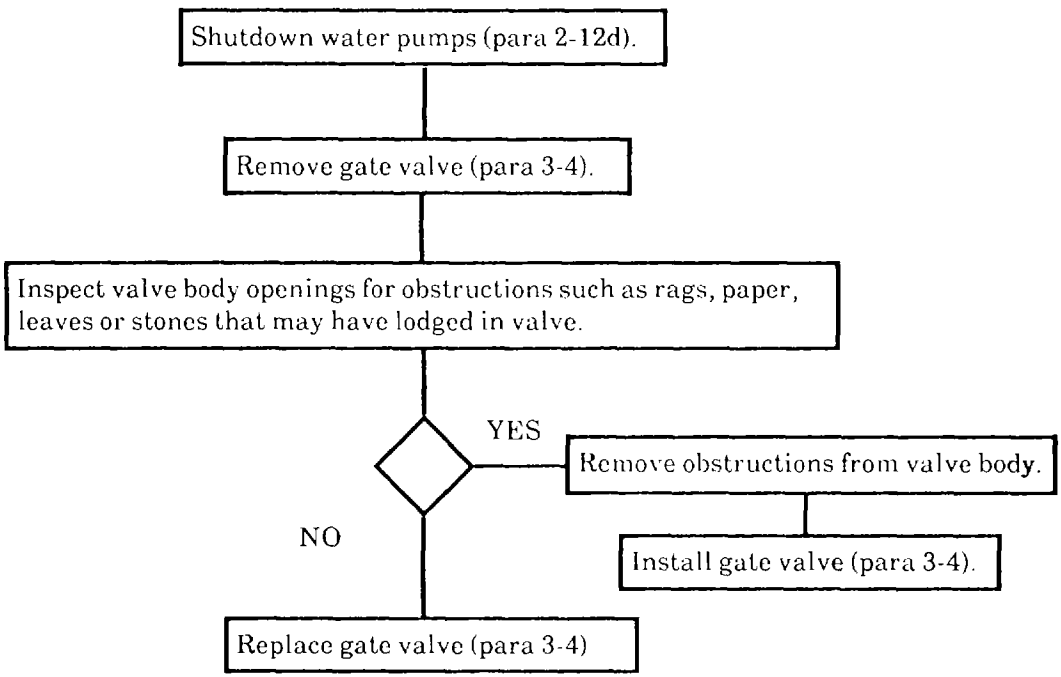

Table 3-1. Operator Troubleshooting - cont.

MALFUNCTION 19. WATER METER ASSEMBLY LEAKS.

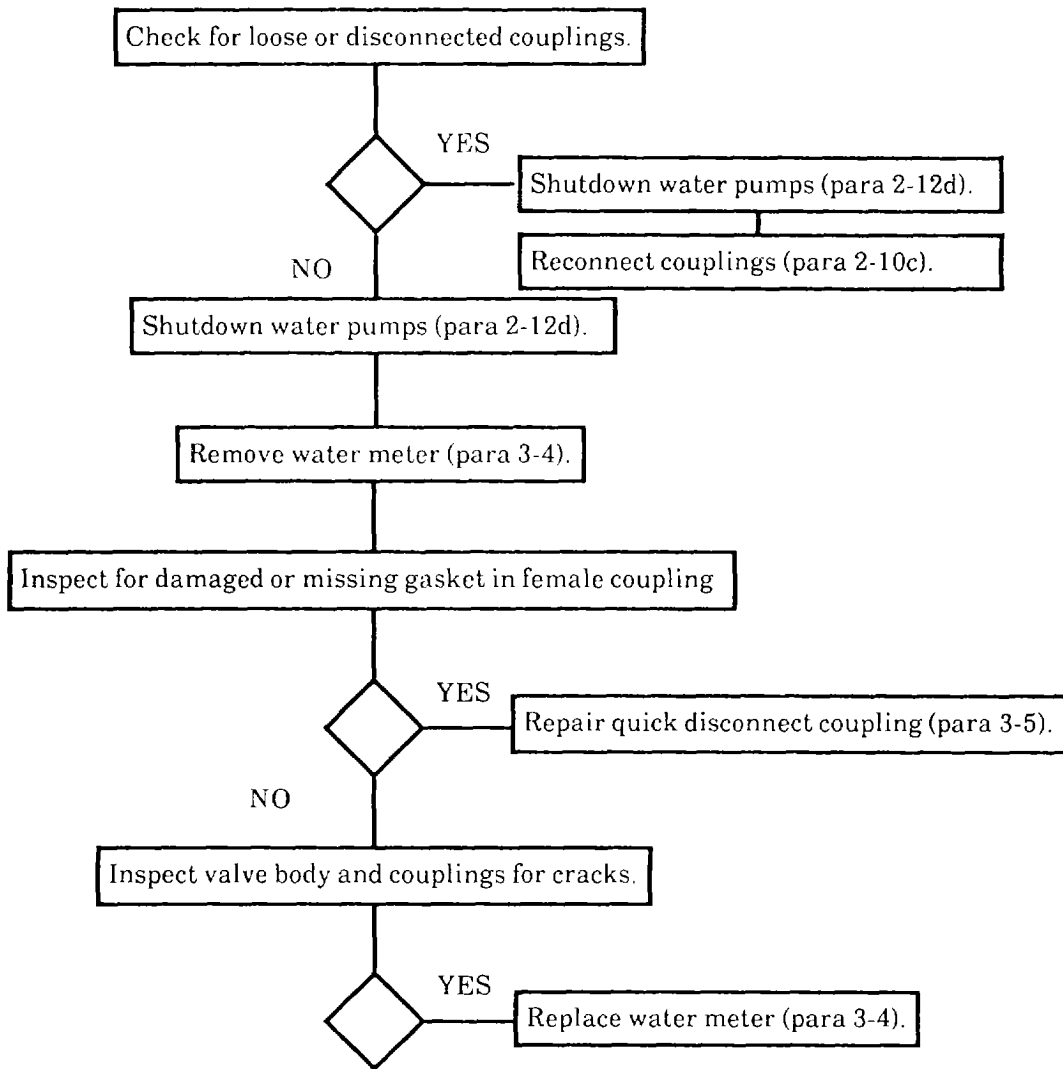

Table 3-1. Operator Troubleshooting - cont.

MALFUNCTION 20. WATER METER ASSEMBLY WILL NOT OPERATE.

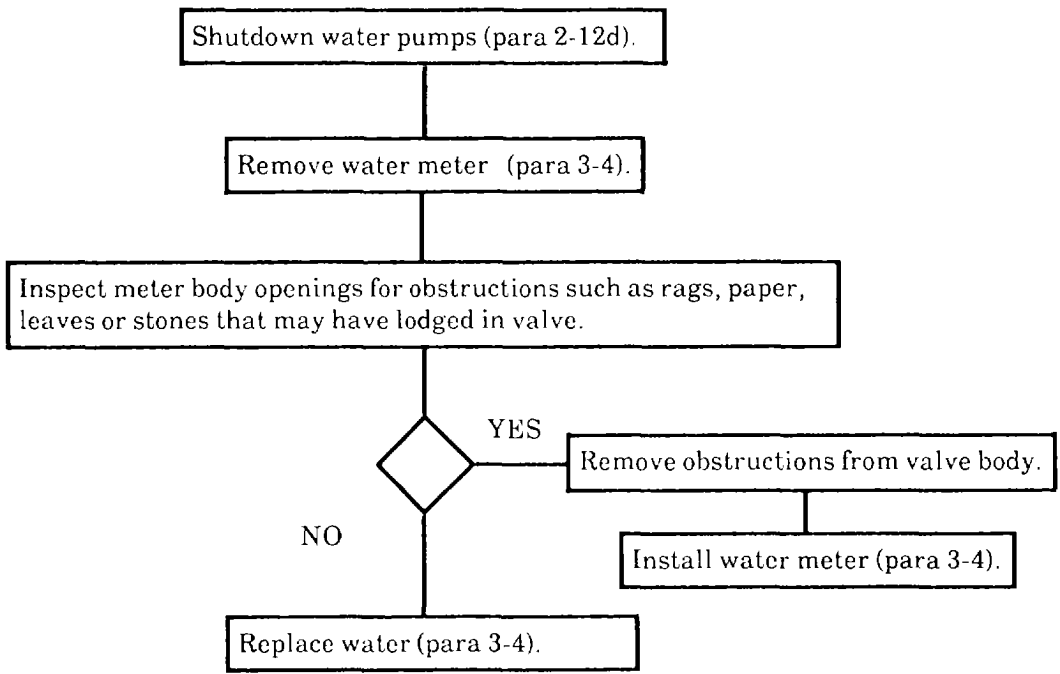

Table 3-1. Operator Troubleshooting - cont.

MALFUNCTION 21. CHECK VALVE LEAKS.

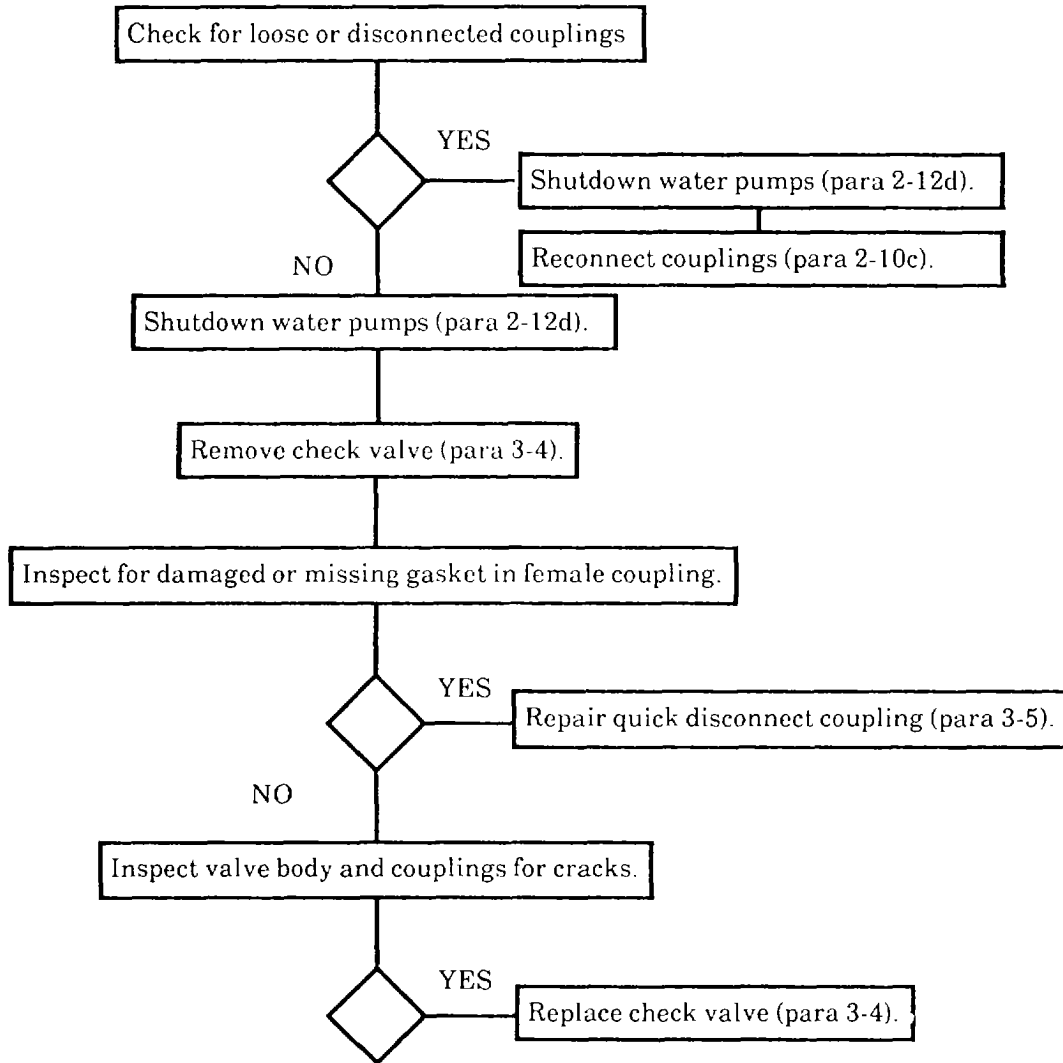
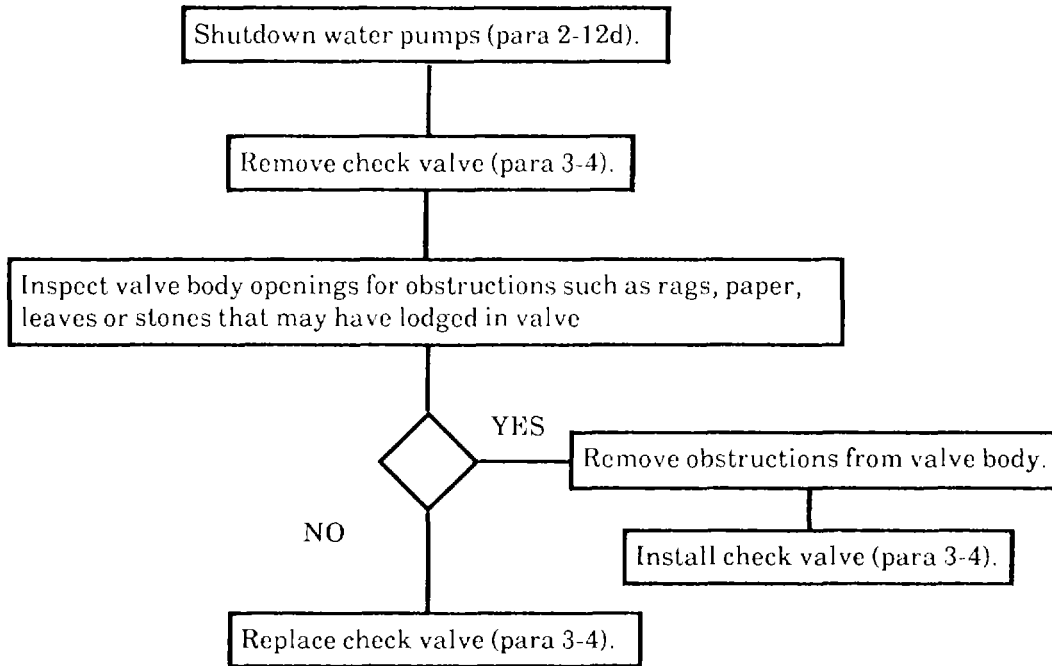

Table 3-1. Operator Troubleshooting - cont.

MALFUNCTION 22. CHECK VALVE STUCK OPEN OR CLOSED.



MALFUNCTION 23. TEE AND VALVE GATE ASSEMBLY LEAKS. Refer to Malfunction 6 to troubleshoot tee. Refer to Malfunction 17 to troubleshoot 4-inch gate valve.

MALFUNCTION 24. TEE AND VALVE GATE ASSEMBLY STUCK OPEN OR CLOSED. Refer to Malfunction 18 to troubleshoot 4-inch gate valve

Section III. OPERATOR MAINTENANCE PROCEDURES**3-4. COMPONENT REPLACEMENT**

Removal of defective components from the assembled water system is accomplished by disconnecting the couplings at both ends of the component and removing the defective item. Installation of replacement components is performed by positioning the new component in the water system and connecting the couplings at both ends of the component

This task consists of: a. Removal b. Installation

INITIAL SET-UP;**General Safety Instructions:****Equipment Condition:**

Water system shutdown (para. 2-12d)

WARNING

To prevent injury to personnel, all water pumps must be shutdown and water pressure relieved from discharge hoses before disconnecting couplings. Call all open couplings to prevent water system contamination

NOTE

Replacement of a typical 4-inch gate valve is shown. Replacement of all water system components is similar

- a. Removal. Refer to figure 3-1.
- (1) Disconnect female coupling (1) from male coupling (2).
 - (2) Disconnect female coupling (3) from male coupling (4).
 - (3) Remove defective 4-inch gate valve (5) from water system.
 - (4) Install cap (6) on male coupling (4)
 - (5) Install plug (7) in female coupling (1).
- b. Installation. Refer to figure 3-1.
- (1) Remove plug (7) from female coupling (1).
 - (2) Remove cap (6) from male coupling (4).
 - (3) Position replacement 4-inch gate valve (5) in water system
 - (4) Connect female coupling (1) to male coupling (2).
 - (5) Connect female coupling (3) to male coupling (4).
 - (6) Startup water system (para. 2-12c) and check for leaks at 4-inch gate valve (5).

3-4. COMPONENT REPLACEMENT - cont.

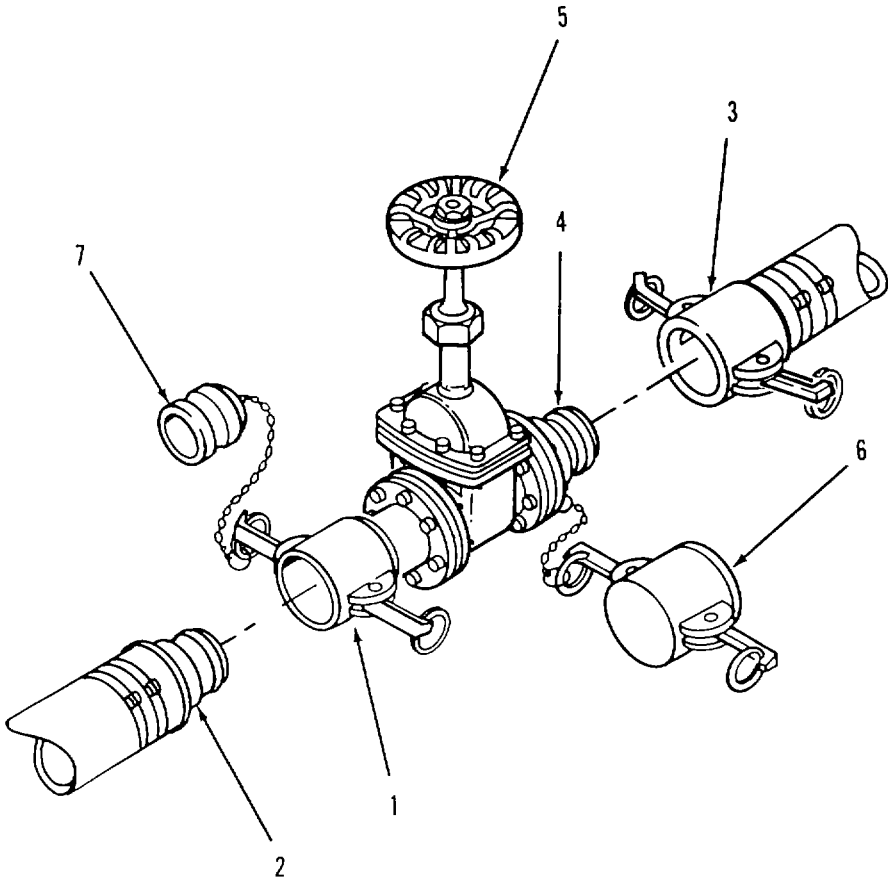

Figure 3-1. Component Replacement.

3-5. QUICK DISCONNECT COUPLING REPAIR.

The following instructions are applicable to both female quick disconnect couplings and caps.

This task consists of: a. Removal b. Installation

INITIAL SET-UP:

Equipment Condition:

Water system shutdown (para. 2-12d)

Materials Required:

Wiping rag (Item 2, App E)
Determine gaskets required from the following table:

General Safety Instructions:

WARNING

To prevent injury to personnel, all water pumps must be shutdown and water pressure relieved from discharge hoses before disconnecting couplings. Cap or plug all open couplings to prevent water system contamination.

Coupling Size	Gasket
1-inch	(Item 1, App I)
1 1/2-inch	(Item 2, App I)
2-inch	(Item 3, App I)
4-inch	Item 4, App I)

NOTES

- Repair of a typical 4-inch female coupling and cap is shown. Repair of 2-inch, 1 1/2-inch and 1-inch couplings and caps is similar.
- Replacement gaskets are supplied in the accessory kit.

a. Removal. Refer to figure 3-2.

- (1) Disconnect female coupling (1) from water system (para 2-10c).
- (2) Pull gasket (2) from interior of female coupling (1).

b. Installation. Refer to figure 3-2.

- (1) Using clean wiping rag, remove grit, sand, and dirt from gasket seat inside female coupling (1).
- (2) Position replacement gasket (2) in female coupling (1).
- (3) Press gasket (2) into gasket seat inside female coupling (1). There will be no ripples or bumps in gasket material when gasket is properly installed.
- (4) Connect coupling (1) to water system (para. 2-10c).
- (5) Startup water system (para. 2-12c) and test coupling (1) for leaks.

3-5. QUICK DISCONNECT COUPLING REPAIR - cont.

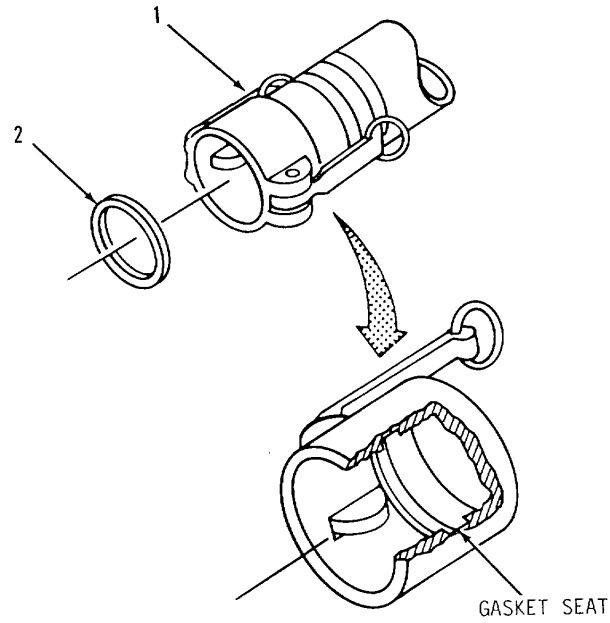

Figure 3-2. Quick Disconnect Repair

3-29/(3-30 Blank)

CHAPTER 4

UNIT MAINTENANCE INSTRUCTIONS

Section I	Repair Parts and Special Tools List	4-2
4-1	Common Tools and Equipment.....	4-2
4-2	Special Tools, TMDE and Support Equipment.....	4-2
4-3	Repair Parts.....	4-2
Section II	Service Upon Receipt	4-2
4-4	Siting	4-2
4-5	Shelter Requirements	4-3
4-6	Checking Unpacked Equipment	4-3
Section III	Unit Troubleshooting Procedures	4-6
4-7	Introduction.....	4-6
4-8	Troubleshooting	4-6
4-9	Malfunction Index.....	4-7
Section IV	Unit Maintenance Procedures	4-27
4-10	General.....	4-27
4-11	Personal Safety	4-27
4-12	Proper Equipment.....	4-27
4-13	Bag Filler Connection Kit Maintenance.....	4-27
4-14	Discharge and Suction Hose Repair.....	4-28
4-15	Gate Valve Assembly (2-inch) Repair	4-33
4-16	Tee Assembly (9117-Y1) Repair	4-36
4-17	Distribution Nozzle (1-Inch) Repair.....	4-40
4-18	Water Pressure Regulator Repair.....	4-44
4-19	Nozzle Stand Assembly Repair	4-51
4-20	Hose Nozzle Kit Maintenance	4-53
4-21	Distribution Nozzle (1-1/2 Inch) Repair.....	4-53
4-22	2-Inch Hose Connection Kit Maintenance.....	4-58
4-23	4-Inch Hose Connection Kit Maintenance.....	4-58
4-24	Butterfly Valve Assembly Repair	4-58
4-25	Quick Acting Valve Assembly Repair	4-63
4-25.1	Tee and Gate Valve Assembly (9133-Y1) Repair (Model 800KWSDS).....	4-68
4-26	350 Gpm Pump Connection Kit.....	4-68.4
4-27	Tee Assembly (9112-Y1) Repair	4-68.4
4-28	Tee Assembly (9112-Y2) Repair	4-72
4-29	Tee Assembly (9112-Y3) Repair	4-76
4-30	Tee Assembly (9112-Y4) Repair	4-80
4-31	Gate Valve (4-inch) Assembly Repair	4-84
4-32	Water Meter Assembly Repair	4-89
4-32.1	Water Meter Assembly Repair (Model 800KWSDS).....	4-92
4-33	125 Gpm Pump Connection Kit Maintenance.....	4-92.3
4-34	Check Valve (2-inch) Repair	4-93
4-35	Dual Tank Connection Kit Maintenance.....	4-96
4-36	Tee and Gate Valve Assembly (9114-Y1) Repair	4-96
4-37	Tee and Gate Valve Assembly (9114-Y2) Repair	4-100
4-38	Tee and Gate Valve Assembly (9114-Y5) Repair	4-104
4-39	Tee and Gate Valve Assembly (9114-Y6) Repair	4-108
4-40	Interconnection Kit Maintenance	4-112
4-41	Tee Assembly (9115-Y) Repair	4-112
4-42	Tee Assembly (9115-Y1) Repair	4-116
4-43	Water Tank Chest Repair.....	4-120
Section V	Preparation for Storage or Shipment	4-130
4-44	Security Procedures.....	4-130
4-45	Administrative Storage.....	4-130

Section I. REPAIR PARTS AND SPECIAL TOOLS LIST

4-1. COMMON TOOLS AND EQUIPMENT.

For authorized common tools and equipment, refer to the Modified Table of Organization and Equipment (MTOE), CTA 50-970 or CTA 8-100, applicable to your unit.

4-2. SPECIAL TOOLS, TMDE AND SUPPORT EQUIPMENT.

Refer to the Maintenance Allocation Chart contained in Appendix B for maintenance tasks authorized at unit level maintenance and the TMDE and support equipment required to perform these tasks. No special tools are required to maintain the 800K Water Storage and Distribution System.

4-3. REPAIR PARTS.

Repair parts are listed and illustrated in the repair parts and special tools list, TM10-4610-242-23P, covering unit, direct support, and general support maintenance of this equipment.

Section II. SERVICE UPON RECEIPT

4-4. SITING.

- a. Transport. The water system is designed to be packaged and shipped inside the twelve tricons supplied with the system. Transport the water system only on equipment compatible with tricon transport requirements (TM55-8145-200-13&P).
- b. Site Selection. When selecting a site for installation of the water system, consider the overall operating area. Siting must include access to the main water source (TWDS), adequate space to set up 16 water tanks and associated hoses, and space for movement of water transport vehicles (minimum space required 260 x 275 feet). Site should be level and provide good water drainage away from system components. If possible, site should slope downhill from water source to water dispensing points.

4-5. SHELTER REQUIREMENTS.

The water system does not require special sheltering during normal operation. Heated shelters are required when operating in extremely cold conditions (below 32° F). Store unused water system components in the tricons to prevent damage and minimize routine maintenance.

4-6. CHECKING UNPACKED EQUIPMENT.

- a. General. The water system is packaged and shipped in 12 tricons and sixteen 50K water tank storage chests. One 50K collapsible fabric tank is stored in each chest. All other components of the water system are shipped in tricon containers. Where possible, save crating inside the tricon for reuse. It will make repacking easier. When uncrating the equipment, keep in mind that the system is made up of different connection kits. This manual addresses installation and use of all connection kits, but you may not need all of these components to perform your mission. Your operating requirements will determine which connection kits/components are needed to perform the mission.
- b. Unpacking 50K Water Tank Chests. Refer to figure 4-1

NOTE

Unpacking of one 50K water tank chest is shown. Unpacking of remaining chests is similar.

- (1) Unfasten eight latches (1)

WARNING

The top cover is heavy and difficult to handle. Two personnel are required to lift top cover from water tank chest

- (2) Lift top cover (2) from water tank chest
- (3) Move four handles (3) to OPEN position and remove end panel (4) from water tank chest. Repeat for other end panel.

WARNING

The side panels are heavy and difficult to handle. Two personnel are required to lift side panels from skid.

- (4) Unlatch four locking pins (5) and lift side panel (6) from skid (7)
- (5) Remove accessory components from water tank chest.
- (6) lift divider pan (8) from skid (7)
- (7) Unfasten tie down straps (9) at both ends of water tank (11).

4-6. CHECKING UNPACKED EQUIPMENT cont.

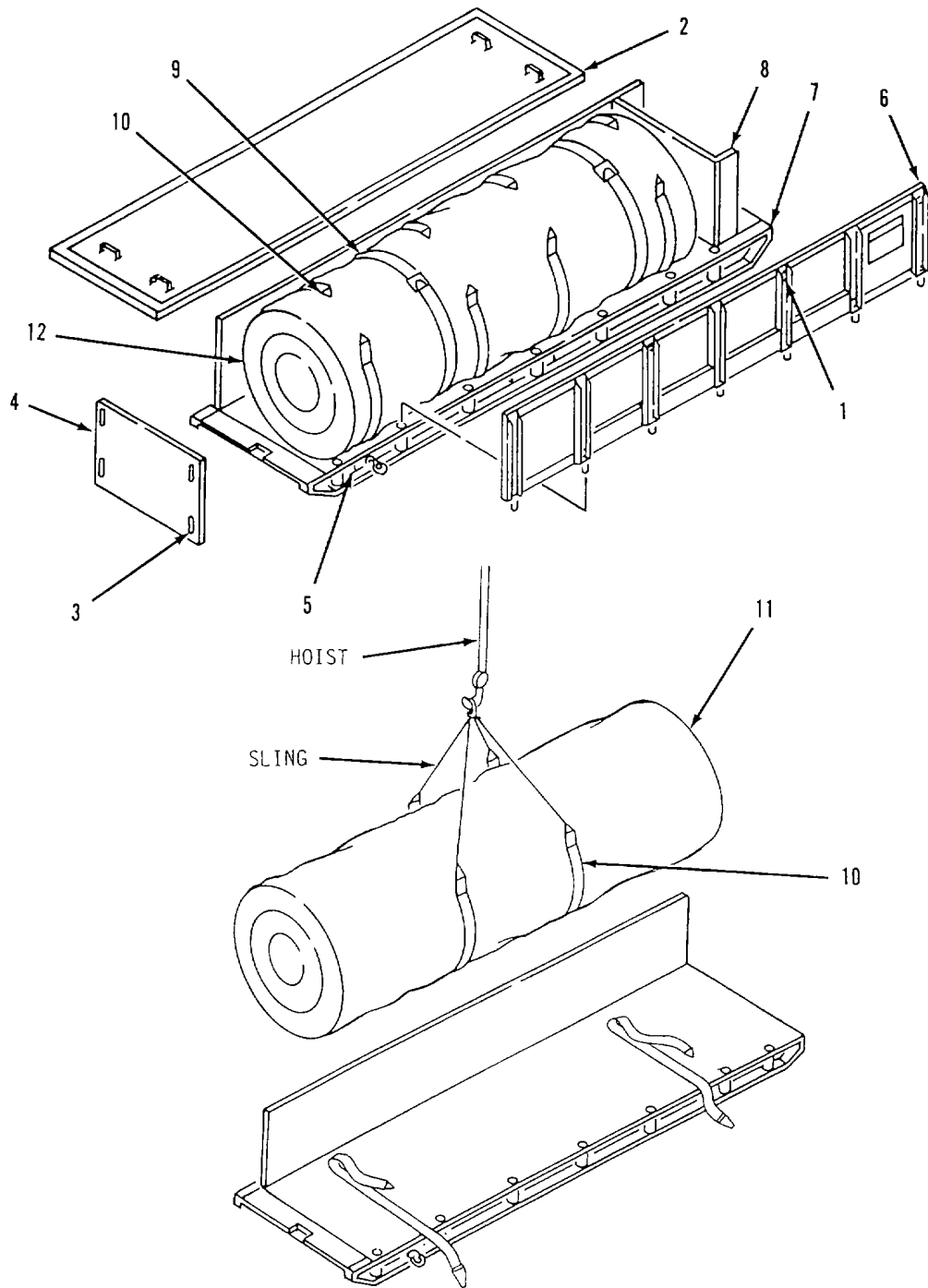

Figure 4-1. Unpacking 50K Water Tank Chest

4-6. CHECKING UNPACKED EQUIPMENT cont.**WARNING**

To prevent injury to personnel and damage to equipment, hoist, crane or similar type equipment having a minimum lifting capacity of 750 pounds must be used to lift water tank from skid.

(8) Connect ends of two center hoisting straps (10) to hoist, crane or similar type equipment.

(9) Lift water tank (11) from skid (7).

c. Unpack Water Pumps and Hypochlorination Units.

(1) Locate tricons containing 350 gpm pumps.

(2) Using forklift, remove 350 gpm pumps from tricons.

(3) Locate tricons containing hypochlorination units.

(4) Using forklift, remove hypochlorination units from tricons.

(5) Locate tricons containing 125 gpm pumps.

(6) Using two personnel, remove 125 gpm pumps from tricons.

(7) Refer to the applicable TM and unpack 350 gpm pumps.

(8) Refer to the applicable TM and unpack 125 gpm pumps.

(9) Refer to the applicable TM and unpack hypochlorination units.

d. Checking Unpacked Equipment.

(1) Inspect tricons and 50K water tanks chest stencils, markings and information plates. All items should be clear and readable.

(2) Inspect the equipment for any damage incurred during shipment. If the equipment has been damaged, report the damage on SF 364, Report of Discrepancy.

(3) Inspect components to make sure they are in serviceable condition.

(4) Check equipment against the packing slip to see if the shipment is complete. Report all discrepancies in accordance with the instructions of DA Pam 750-8 or DA Pam 738-751 as applicable.

(5) Check to see if the equipment has been modified.

4-6. CHECKING UNPACKED EQUIPMENT - cont.e. Processing Unpacked Equipment

- (1) Remove all tape, paper wrapping, plastic sheeting and packing materials from the water system components.
- (2) Refer to the applicable TM for processing and servicing the 350 gpm pumps.
- (3) Refer to the applicable TM for processing and servicing the 125 gpm pumps.
- (4) Refer to the applicable TM for processing and servicing the hypochlorination units.
- (5) Refer to the applicable TM for processing the 50K collapsible fabric tanks.

Section III. UNIT TROUBLESHOOTING PROCEDURES**4-7. INTRODUCTION.**

This section provides the troubleshooting information for the 800K Water Storage and Distribution System at the Unit Maintenance level. It consists of the symptom index, listing the most common malfunction symptoms, and the troubleshooting table, Table 4-1. This table repeats the malfunctions, and provides the procedural steps and corrective actions necessary to return the system to operational readiness.

4-8. TROUBLESHOOTING.

- a. The troubleshooting table lists the common malfunctions which you may find during operation of the water system. You should perform the tests, inspections and corrective actions in the order they appear in the table.
- b. This table cannot list all the malfunctions that may occur, all the tests or inspections needed to find the fault, or all the corrective actions needed to correct the fault. If the equipment malfunction is not listed or actions listed do not correct the fault, notify your supervisor.
- c. Refer to the applicable TM for troubleshooting malfunctions on the 350 gpm pumps.
- d. Refer to the applicable TM for troubleshooting malfunctions on the 125 gpm pump.
- e. Refer to the applicable TM for troubleshooting malfunctions on the hypochlorination units.
- f. Refer to the applicable TM for troubleshooting malfunctions on the 50K collapsible fabric tanks.

4-9. MALFUNCTION INDEX.

Malfunction	Page
1. Discharge or Suction Hose Leaks	4-8
2. Gate Valve Assembly (2-inch) Leaks	4-9
3. Gate Valve Assembly (2-inch) Stuck or Jammed	4-10
4. Tee Assembly (All) Leaks	4-11
5. Distribution Nozzle (1-Inch) Leaks	4-12
6. Distribution- Nozzle (1-Inch) Stuck Open or Closed	4-13
7. Water Pressure Regulator Leaks	4-14
8. Water Pressure Regulator Pressure Not Correct	4-15
9. Distribution Nozzle (1-1/2 Inch) Beaks	4-16
10. Distribution Nozzle (1-1/2 Inch) Stuck Open or- Closed	4-17
11. Butterfly Valve Assembly Leaks	4-18
12. Butterfly Valve Assembly Stuck Open or Closed	4-19
13. Quick Acting Valve Assembly Leaks	4-20
14. Quick Acting Valve Assembly Stuck Open or- Closed	4-21
15. Gate Valve (4-inch) Assembly Leaks	4-22
16. Gate Valve (4-inch) Assembly Stuck Open or Closed	4-23
17. Water Meter Assembly Leaks	4-24
18. Water Meter Will Not Operate	4-25
19. Check Valve (2-inch) Leaks	4-25
20. Check Valve (2-inch) Stuck Open or Closed	4-26
21. Tee and Gate Valve Assembly (All) Leaks	4-26
22. Tee and Gate Valve Assembly (All) Stuck Open or Closed	4-26

Table 4-1. Unit Troubleshooting

MALFUNCTION 1. SUCTION OR DISCHARGE HOSE LEAKS.

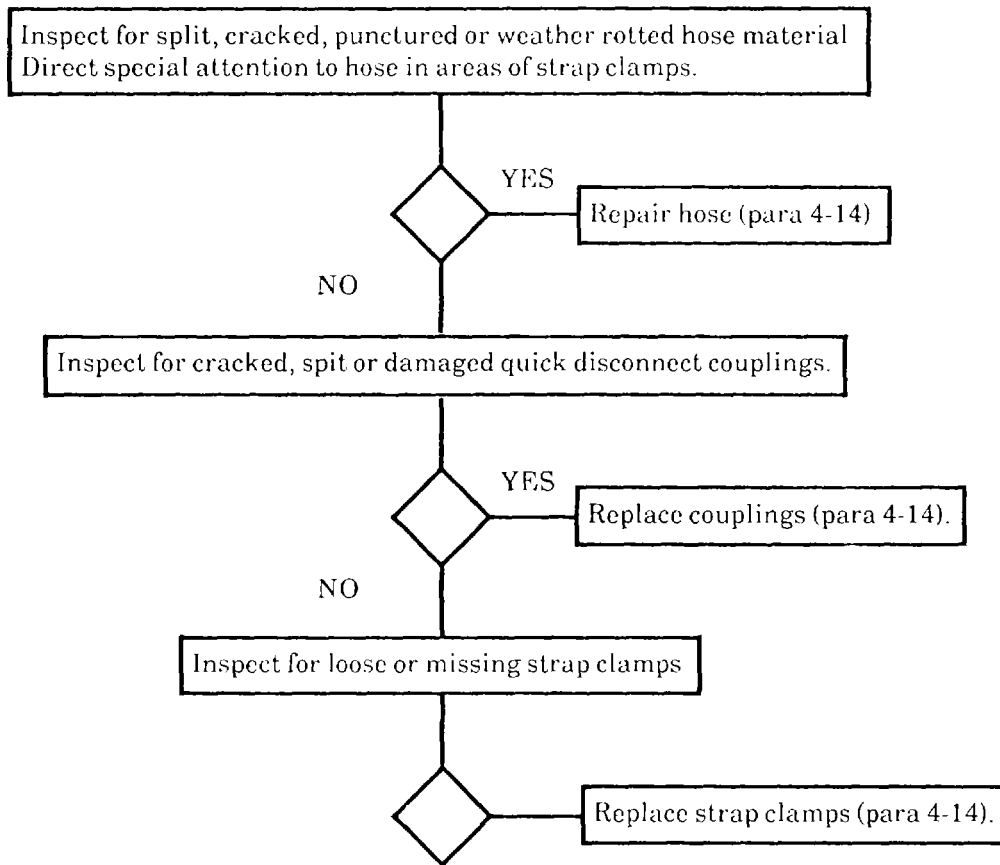

Table 4-1. Unit Troubleshooting

MALFUNCTION 2. GATE VALVE ASSEMBLY (2-INCH) LEAKS.

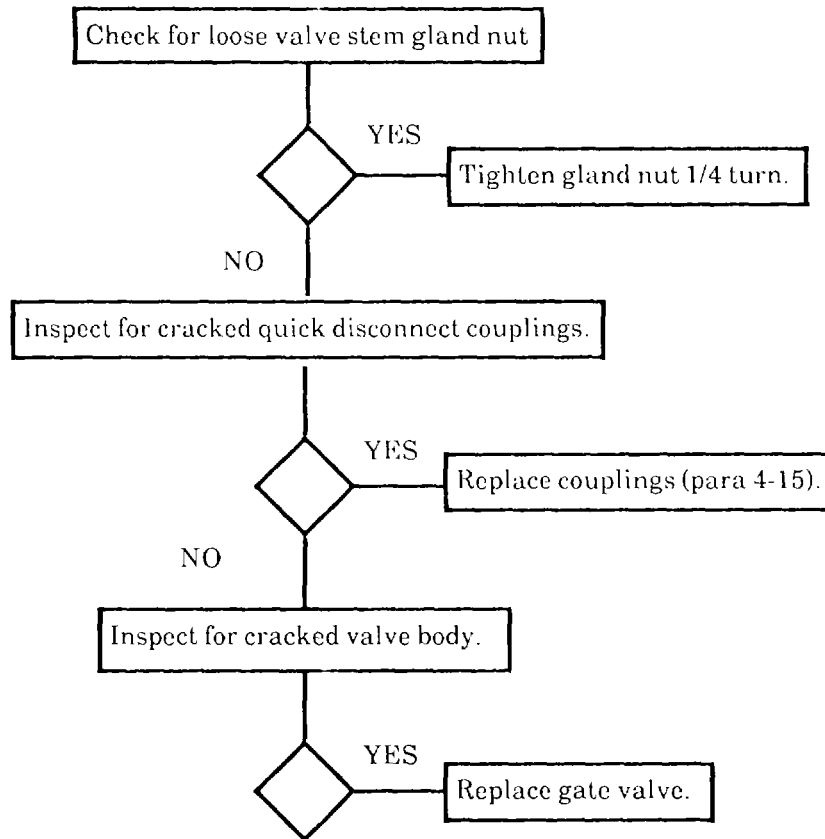

Table 4-1. Unit Troubleshooting - cont.

MALFUNCTION 3. GATE VALVE ASSEMBLY (2-INCH) STUCK OR JAMMED.

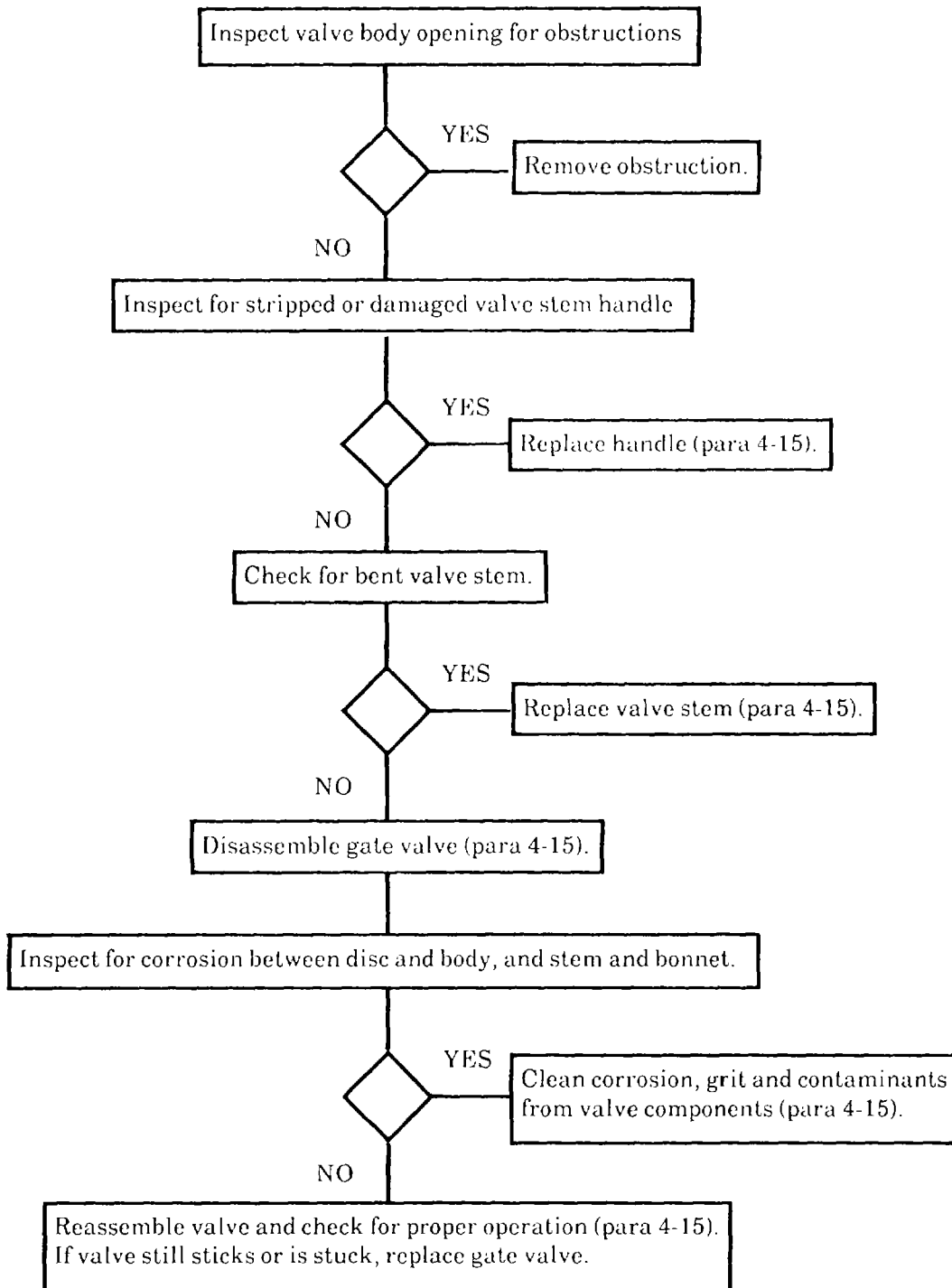

Table 4-1. Unit Troubleshooting - cont.

MALFUNCTION 4. TEE ASSEMBLY LEAKS.

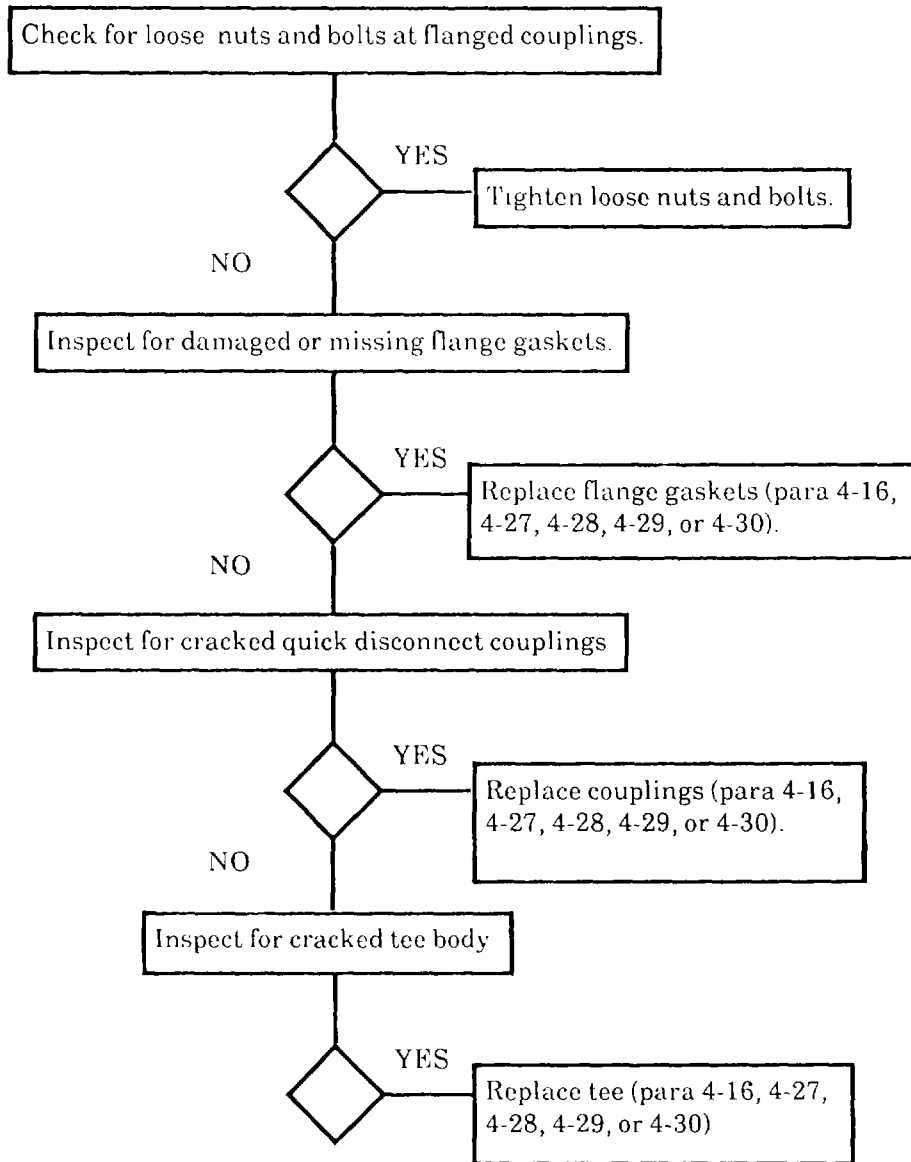

Table 4-1. Unit Troubleshooting - cont.

MALFUNCTION 5. DISTRIBUTION NOZZLE (1-INCH) LEAKS.

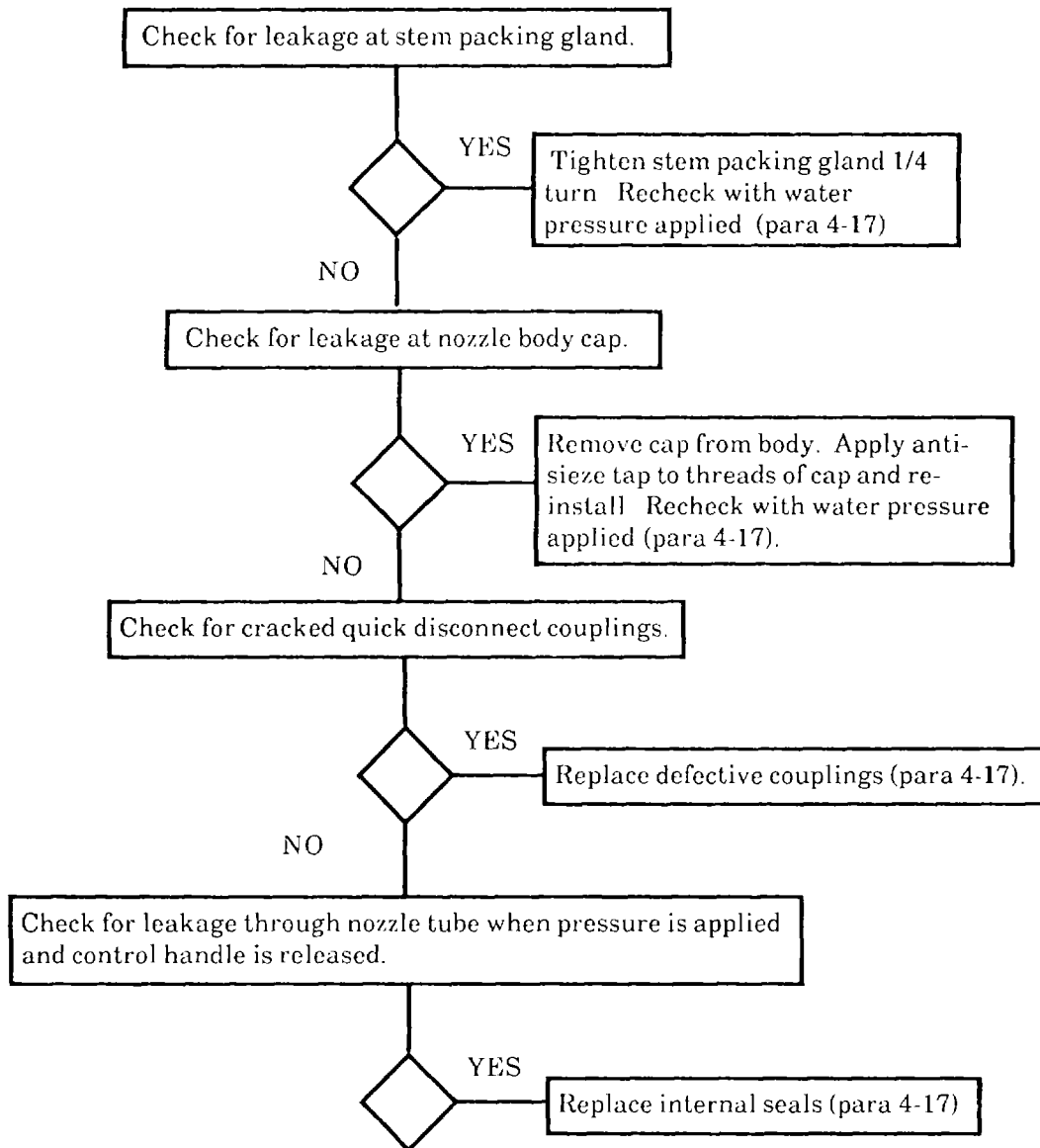

Table 4-1. Unit Troubleshooting - cont.

MALFUNCTION 6. DISTRIBUTION NOZZLE (1-INCH) STUCK OPEN OR CLOSED.

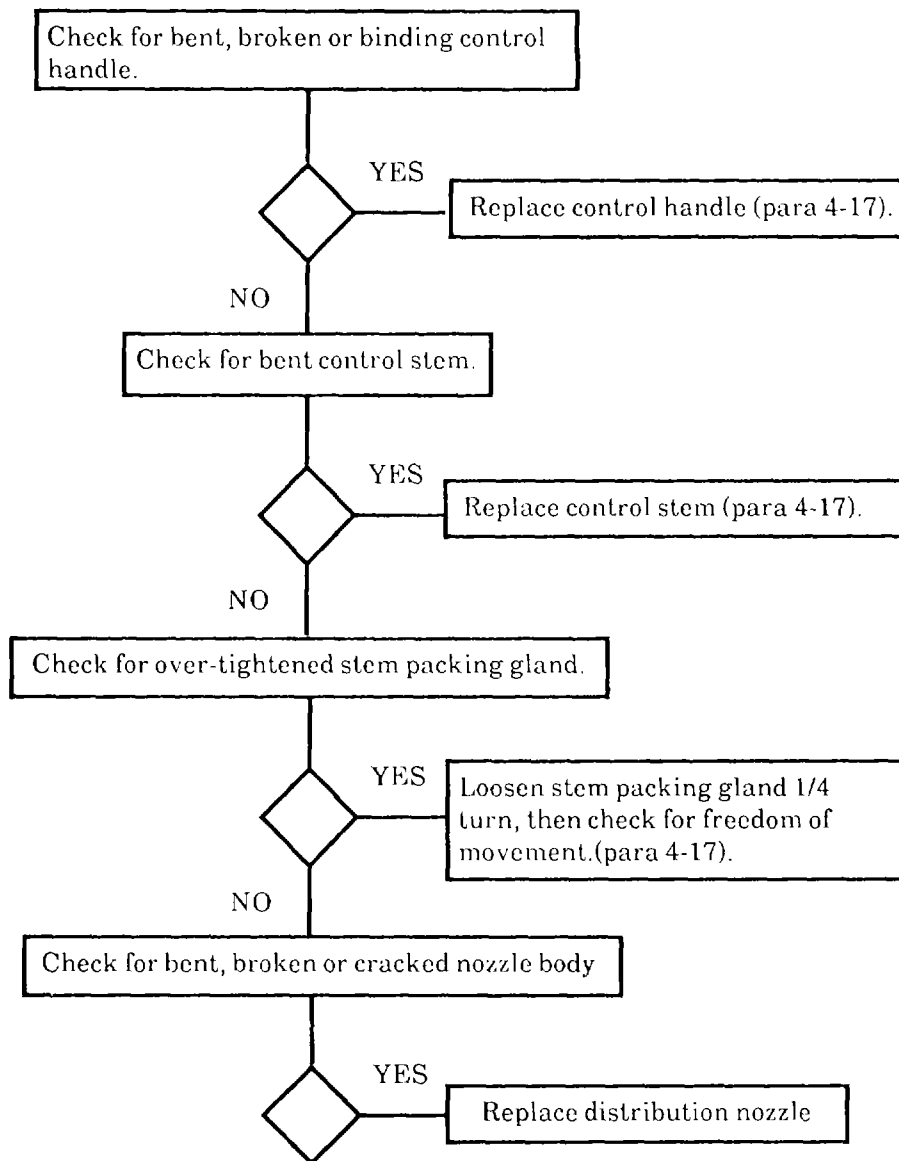

Table 4-1. Unit Troubleshooting - cont.

MALFUNCTION 7. WATER PRESSURE REGULATOR LEAKS.

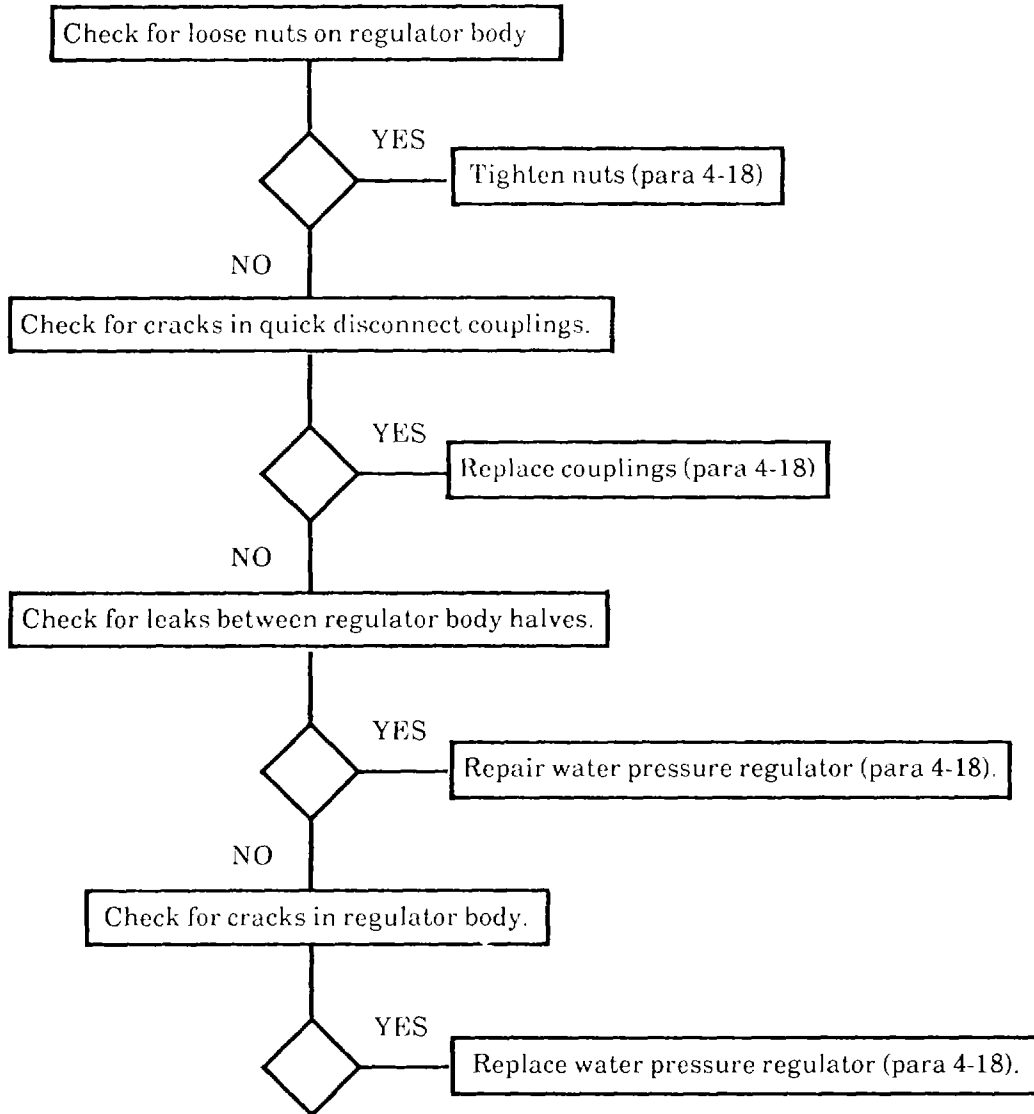

Table 4-1. Unit Troubleshooting - cont.

MALFUNCTION 8. WATER PRESSURE REGULATOR PRESSURE NOT CORRECT.

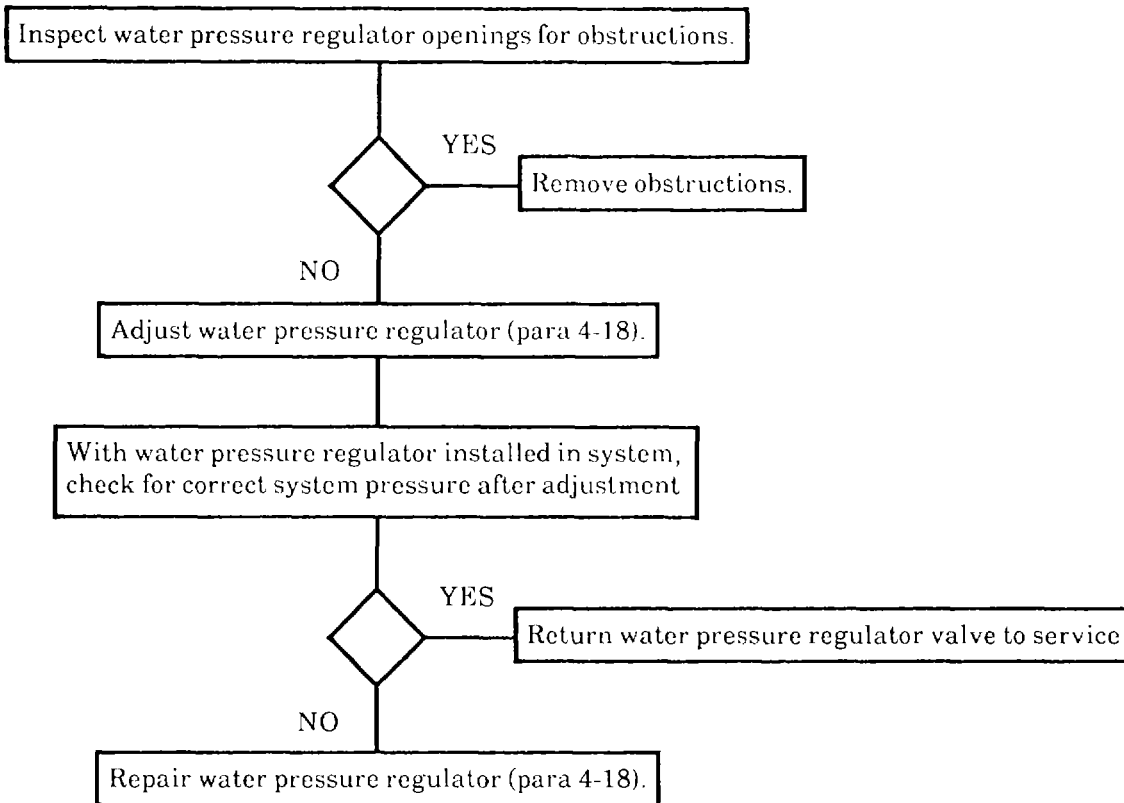

Table 4-1. Unit Troubleshooting - cont.

MALFUNCTION 9. DISTRIBUTION NOZZLE (1-1/2 INCH) LEAKS.

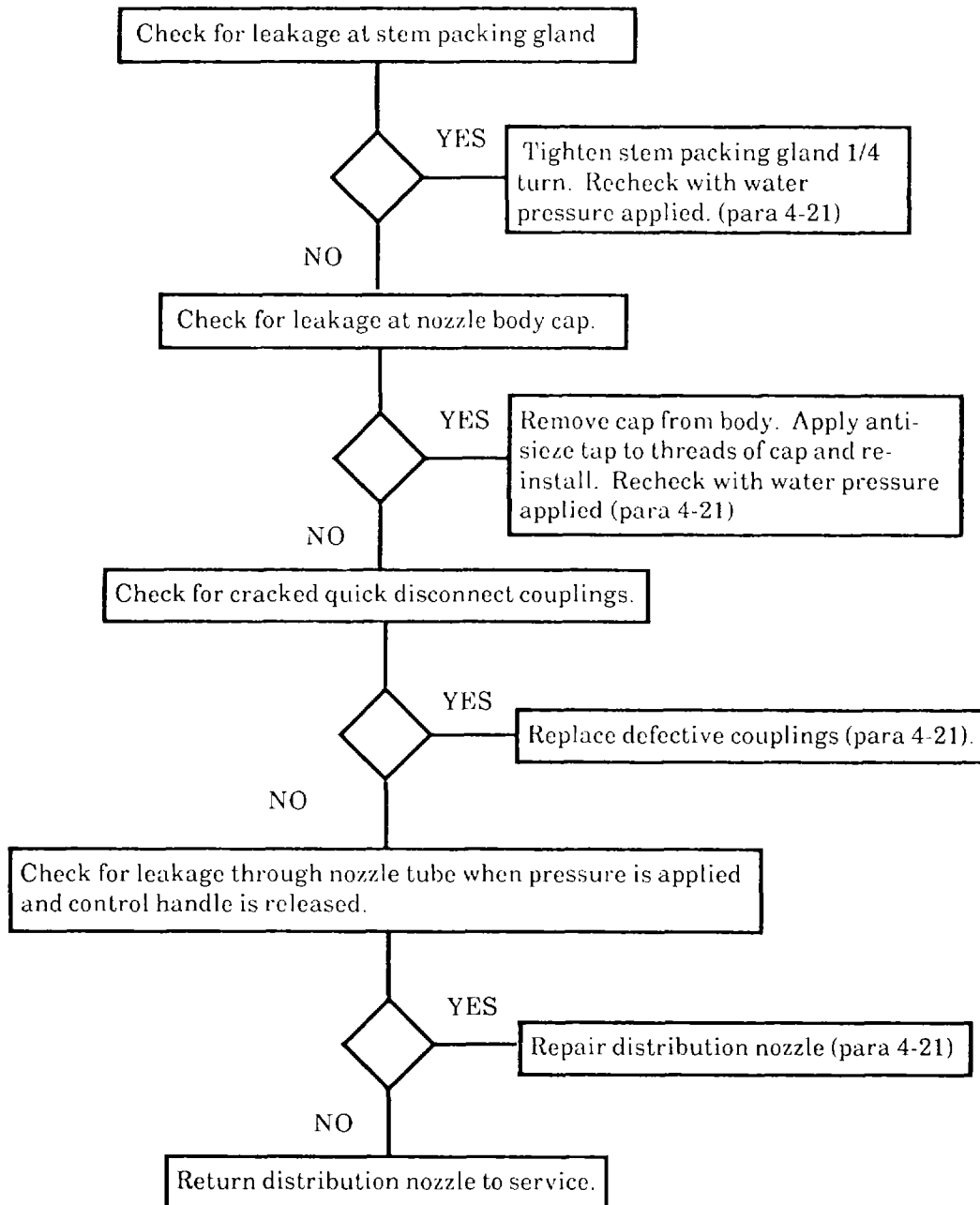

Table 4-1. Unit Troubleshooting - cont.

MALFUNCTION 10. DISTRIBUTION NOZZLE (1-1/2 INCH) STUCK OPEN OR CLOSED.

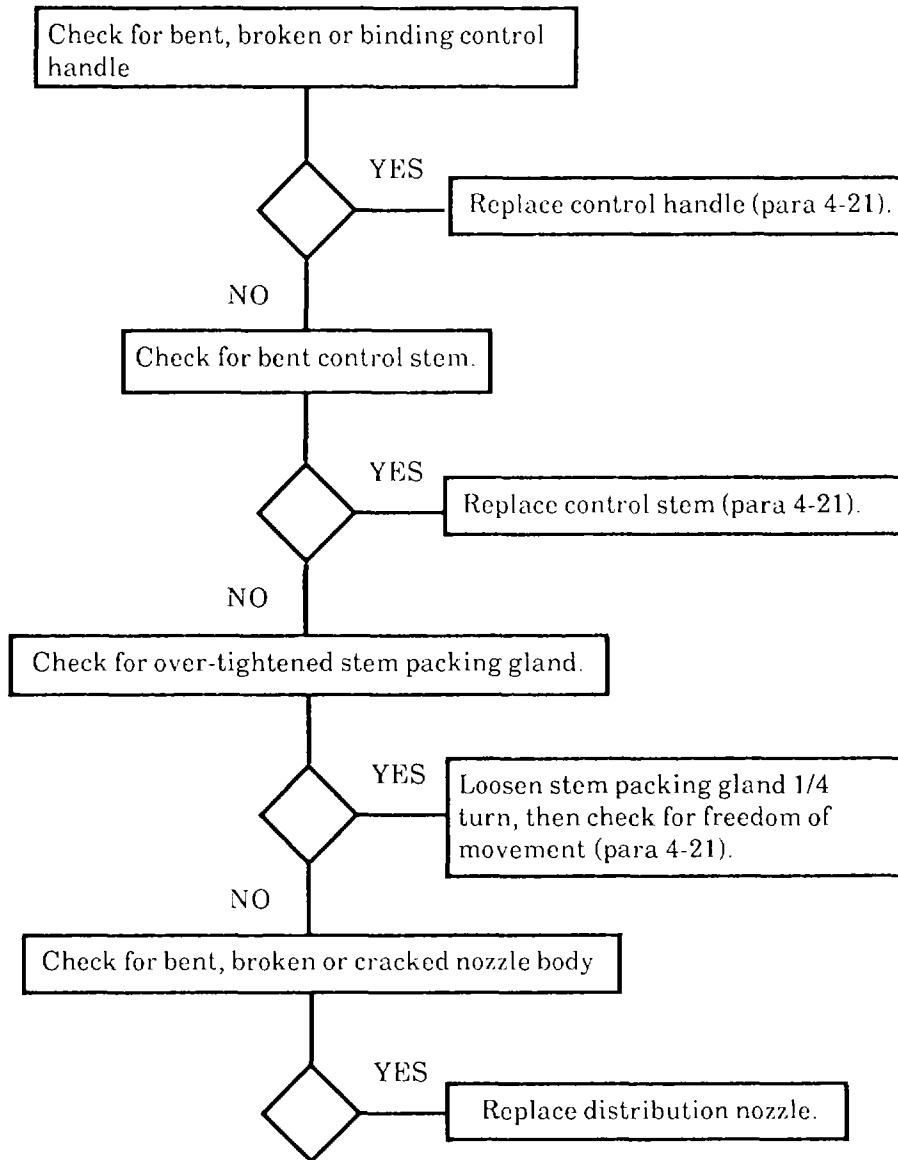

Table 4-1. Unit Troubleshooting - cont.

MALFUNCTION 11. BUTTERFLY VALVE ASSEMBLY LEAKS.

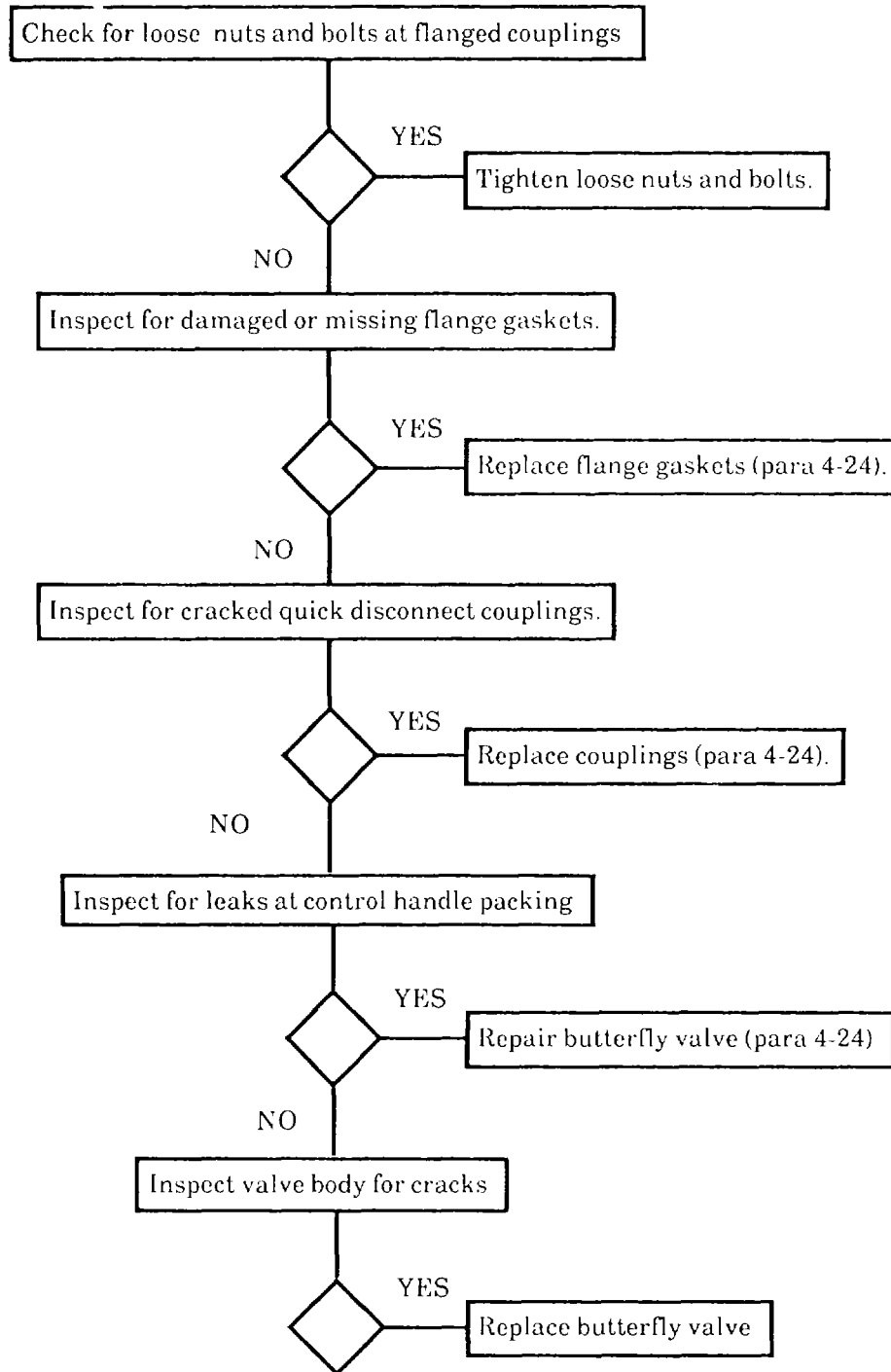

Table 4-1. Unit Troubleshooting - cont.

MALFUNCTION 12. BUTTERFLY VALVE ASSEMBLY STUCK OPEN OR CLOSED.

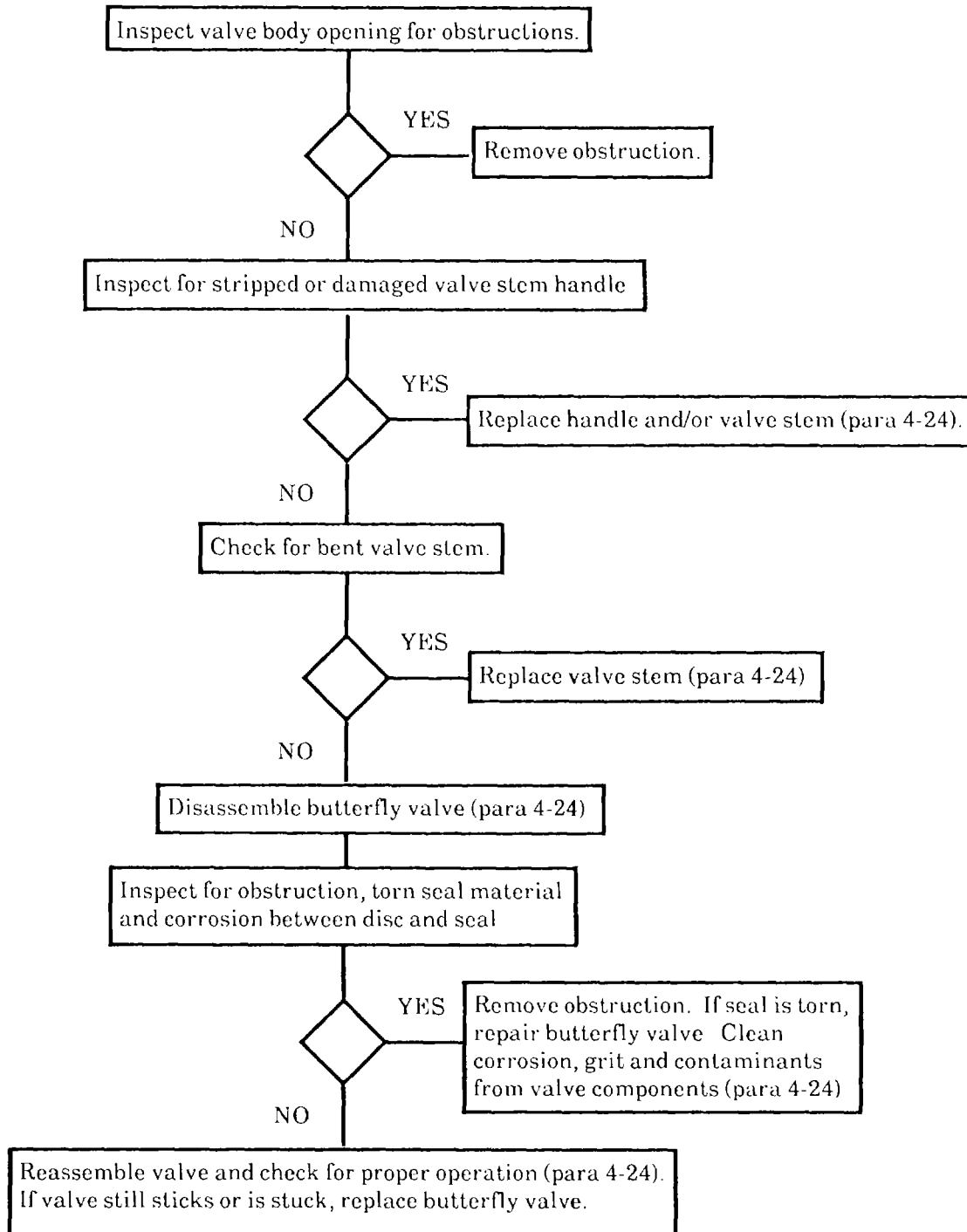

Table 4-1. Unit Troubleshooting - cont.

MALFUNCTION 13. QUICK ACTING VALVE ASSEMBLY LEAKS.

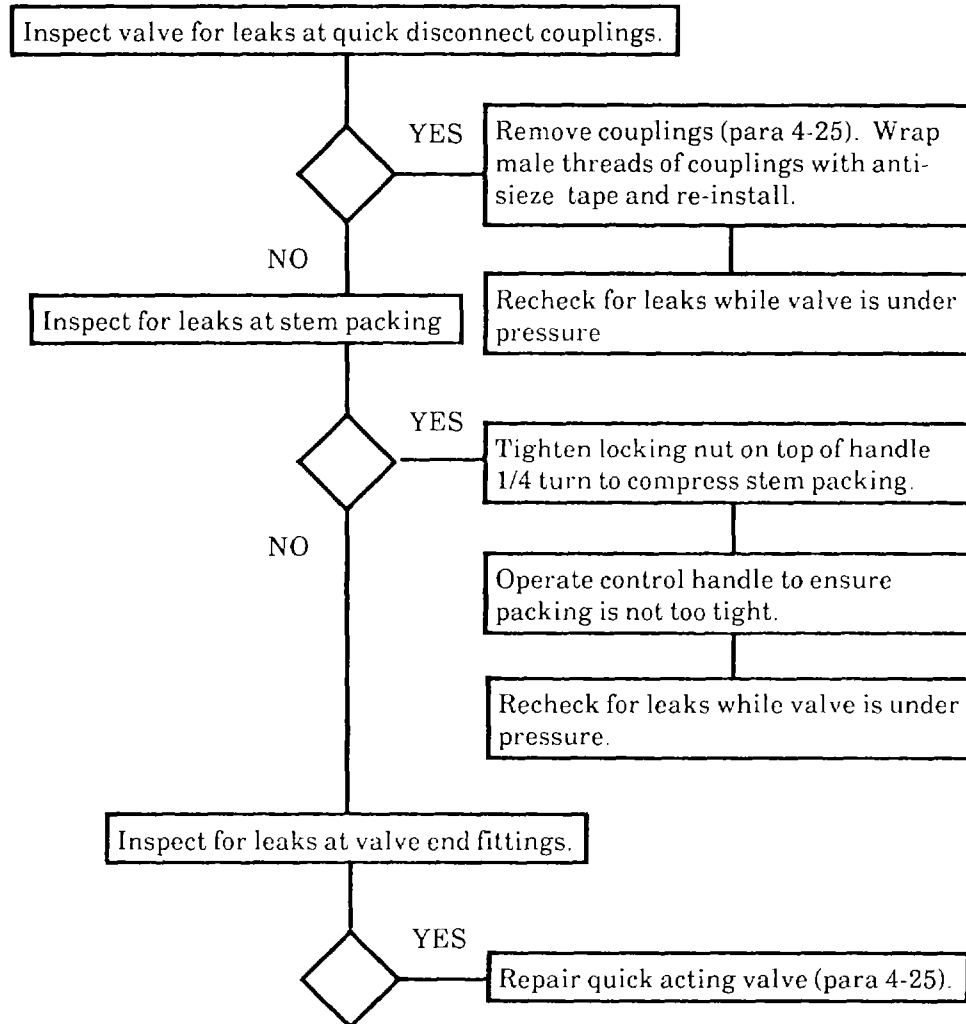

Table 4-1. Unit Troubleshooting - cont.

MALFUNCTION 14. QUICK ACTING VALVE ASSEMBLY STUCK OPEN OR CLOSED.

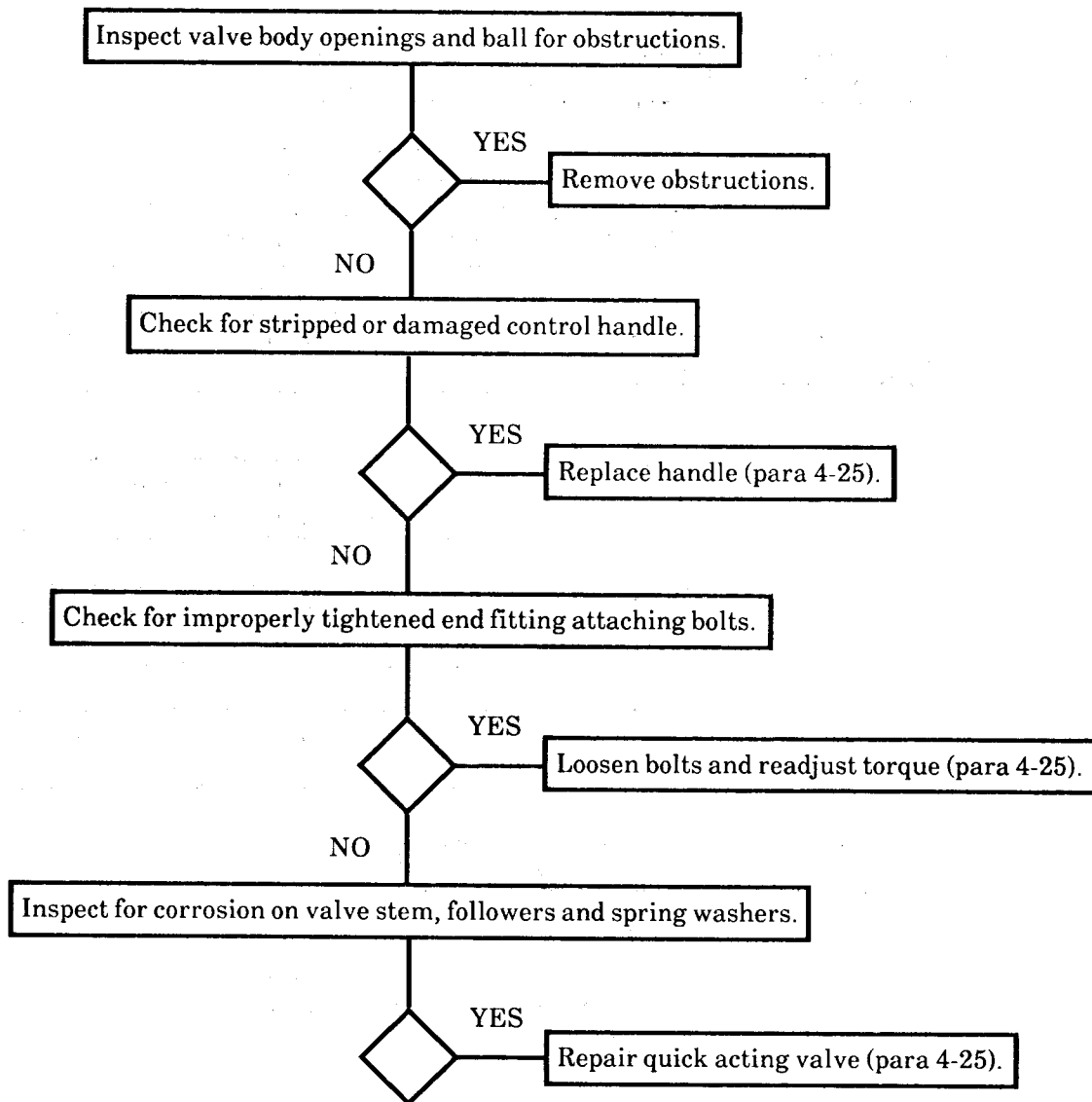

Table 4-1. Unit Troubleshooting - cont.

MALFUNCTION 15. GATE VALVE ASSEMBLY (4-INCH) LEAKS.

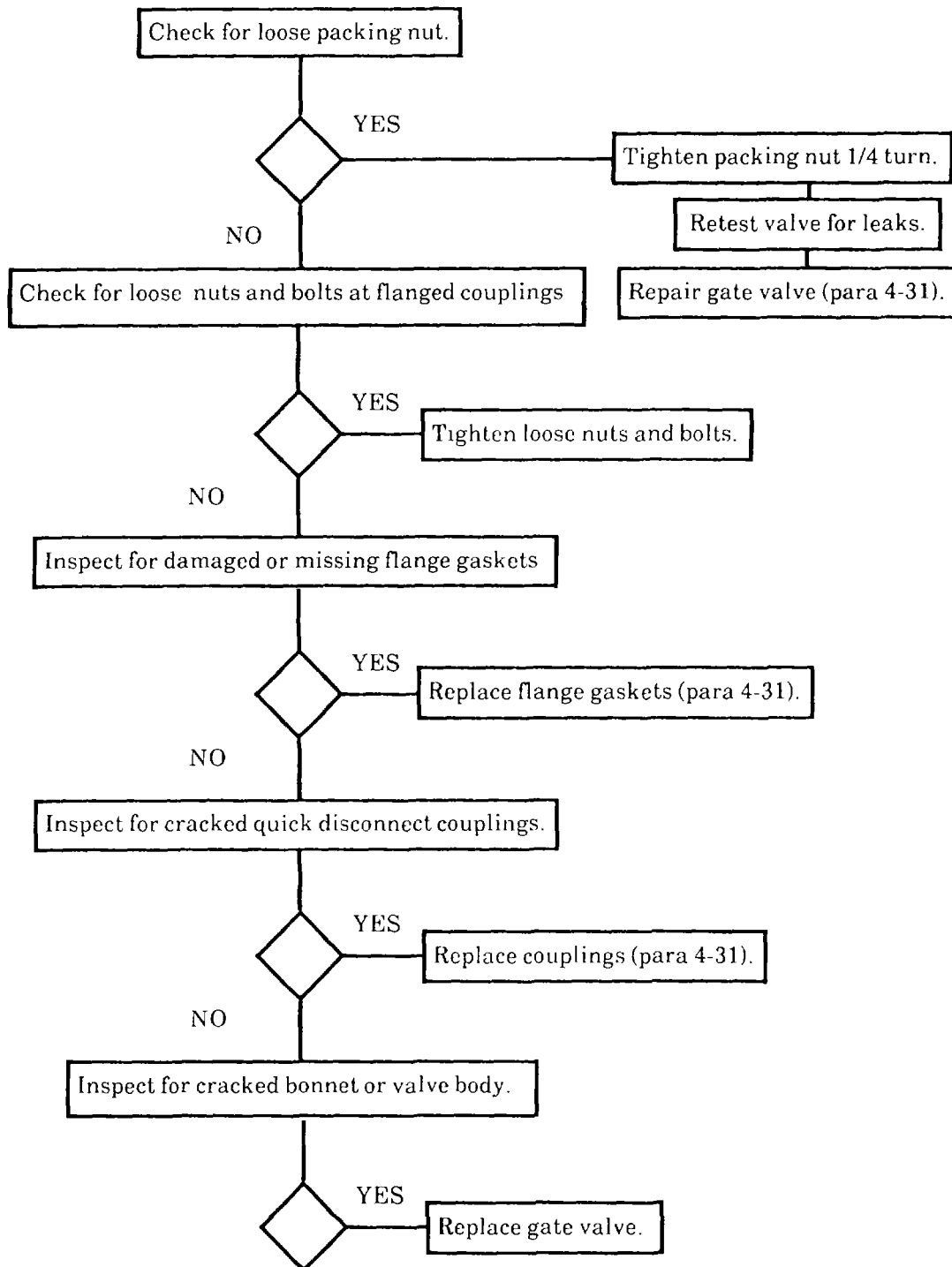

Table 4-1. Unit Troubleshooting - cont.

MALFUNCTION 16. GATE VALVE ASSEMBLY (4-INCH) STUCK OPEN OR CLOSED.

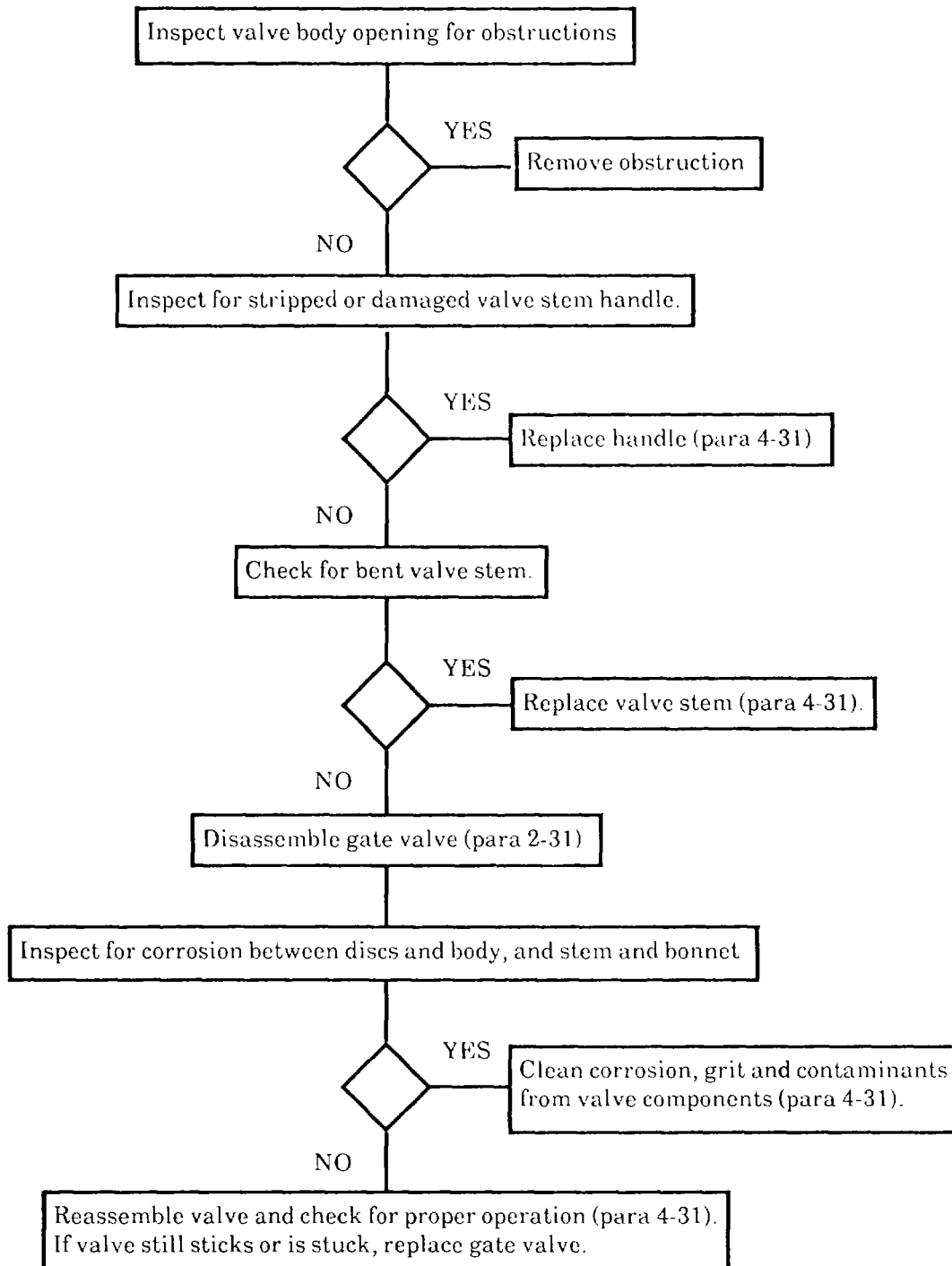

Table 4-1. Unit Troubleshooting - cont.

MALFUNCTION 17. WATER METER ASSEMBLY LEAKS.

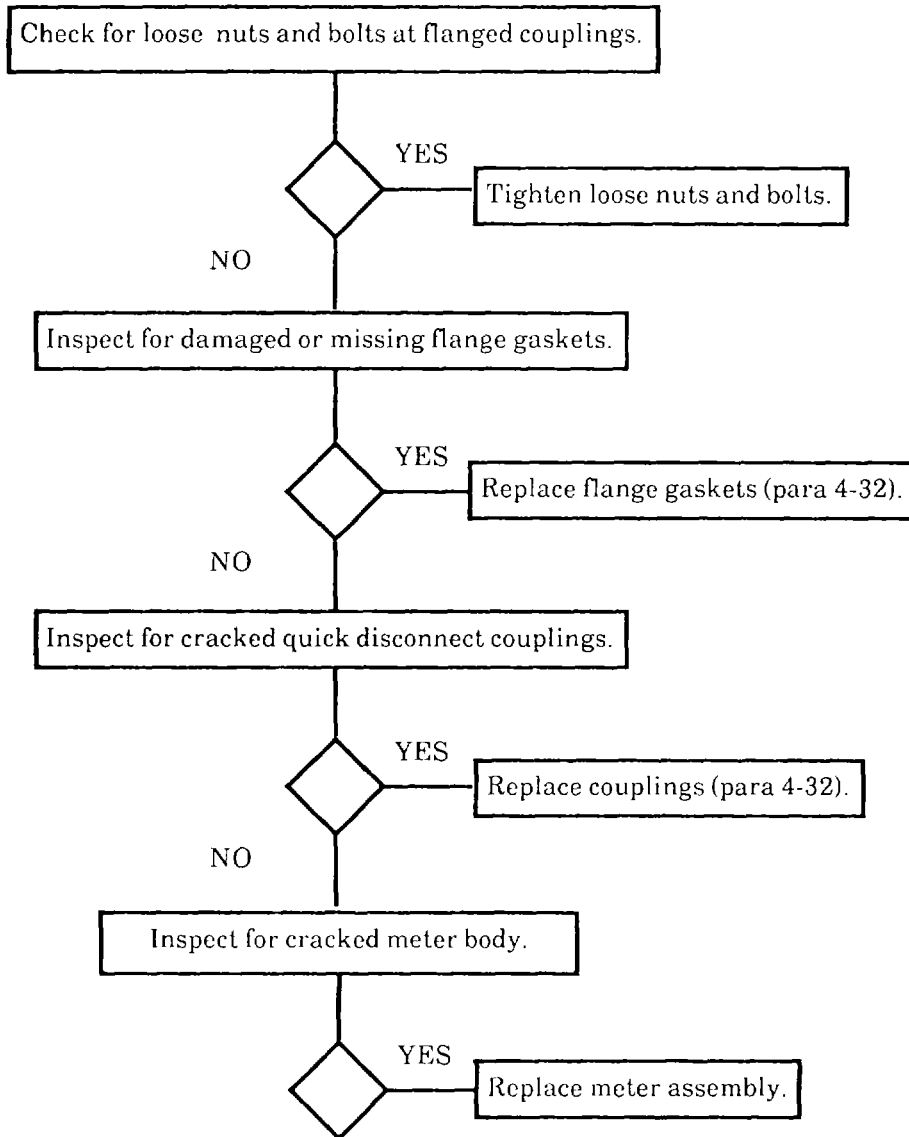
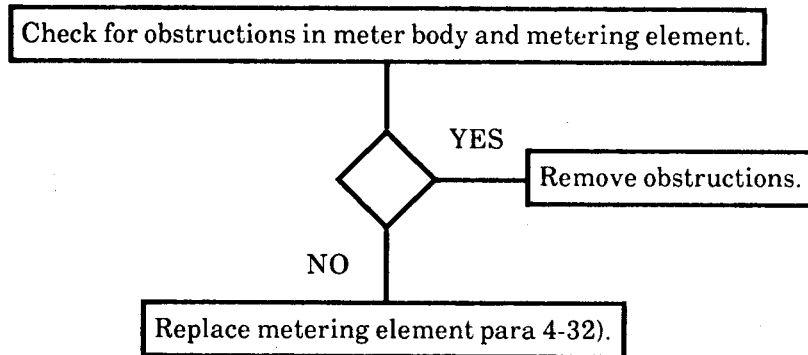

Table 4-1. Unit Troubleshooting - cont.

MALFUNCTION 18. WATER METER ASSEMBLY WILL NOT OPERATE.



MALFUNCTION 19. CHECK VALVE LEAKS.

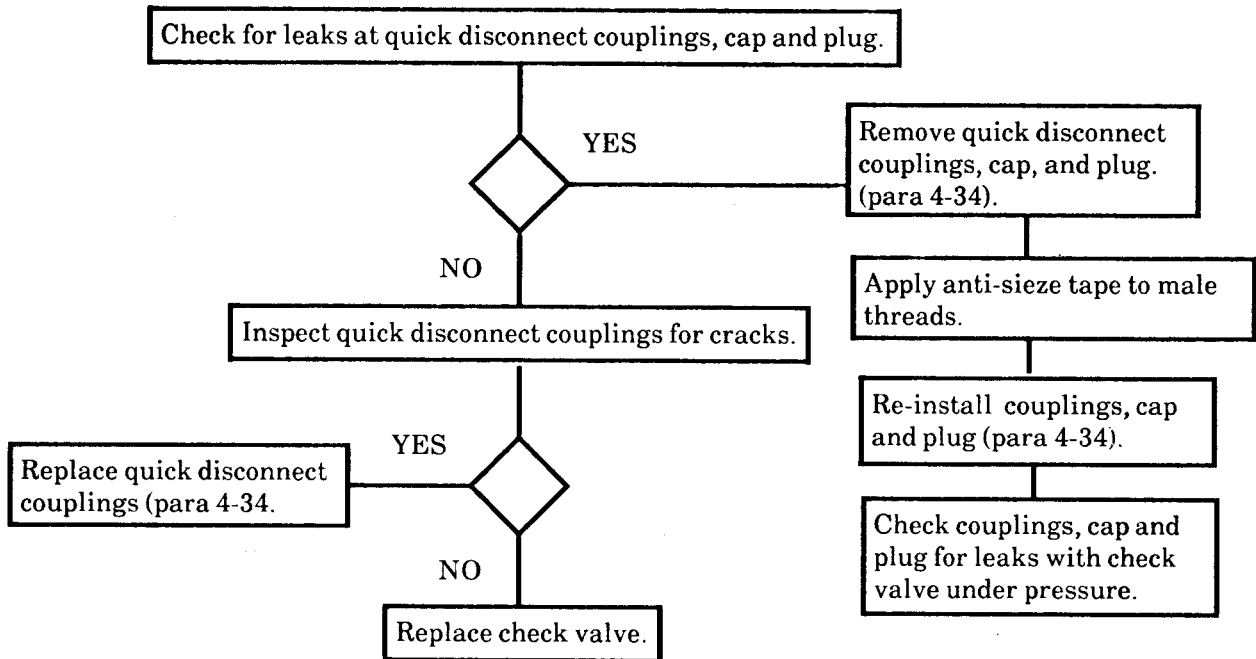
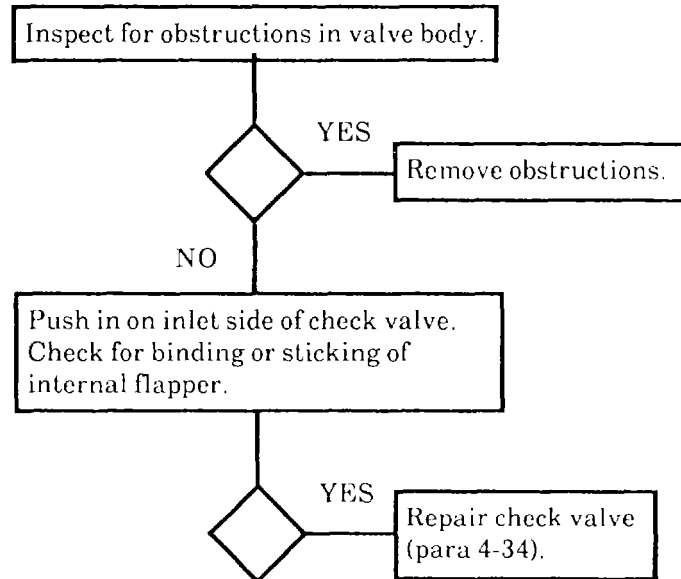

Table 4-1. Unit Troubleshooting - cont.

MALFUNCTION 20. CHECK VALVE STUCK OPEN OR CLOSED.



MALFUNCTION 21. TEE AND GATE VALVE ASSEMBLY LEAKS. Refer to Malfunction 4 to troubleshoot tee. Refer to Malfunction 15 to troubleshoot 4-inch gate valve.

MALFUNCTION 22. TEE AND GATE VALVE ASSEMBLY STUCK OPEN OR CLOSED. Refer- to Malfunction 15 to troubleshoot 4-inch gate valve.

Section IV. UNIT MAINTENANCE PROCEDURES

4-10. GENERAL.

This section contains instructions for performing unit level maintenance on the 800K Water Storage and Distribution System. Refer to applicable technical manuals for unit maintenance on the following equipment:

Equipment	Technical Manual
Hypochlorination Unit	Applicable TM.
125 GPM Pump Assembly	Applicable TM.
350 GPM Pump Assembly	Applicable TM.
50K Collapsible Fabric Tank	Applicable TM.
Tricon	TM55-8145-200-13&P.

4-11. PERSONAL SAFETY.

To ensure safety of personnel, proper care should be used when handling assemblies and parts. Many assemblies are heavy. The assistance of another person, lifting device, or other support equipment may be required to move or position heavy items.

Personnel must remove all items of jewelry (rings, bracelets, watches, necklaces etc) and loose clothing before working on the equipment Jewelry and loose clothing can get caught in moving equipment and result in injury to personnel. Jewelry can cause electrical shorts or severe injury when working around electrical equipment.

When performing maintenance on the water system, keep in mind that the purpose of the equipment is to store and distribute potable water. Cleaning fluids, lubricants, preservatives, paint or other chemicals must not be allowed to contaminate the water system. Clean water system components with only approved materials.

Operate the water system after performing maintenance to ensure repairs have been performed correctly and system can be returned to service

4-12. PROPER EQUIPMENT.

Obtain proper equipment before beginning maintenance This includes hand tools and/or special tools, receptacles for storing small parts, and expendable materials required by the maintenance task

4-13. BAG FILLER CONNEC'I'ION KI' MAINTENANCE.

The bag filler connection kit consists of the components listed below. Refer to the following paragraphs for applicable maintenance procedures.

Procedure	Para.
Distribution Nozzle (1-Inch) Repair	4-17
Gate Valve Assembly (2-inch)Repair	4-15
Discharge Hose Repair	4-14
Nozzle Stand Assembly Repair	4-19
Tee Assembly (Y1) Repair	4-16
Water Pressure Regulator Assembly Repair	4-18

4-14. DISCHARGE AND SUCTION HOSE REPAIR.

NOTE

The following procedure applies to all sizes and lengths of discharge and suction hoses used in the water system.

- This task consists of:
- a. Disassembly
 - b. Cleaning
 - c. Inspection
 - d. Repair
 - e. Assembly

INITIAL SET-UP:	
<p>Tools: General Mechanics Tool Kit (Item 1, App B) Clamping Tool (from accessory kit) Vice (Item 2, App B)</p> <p>Equipment Condition: Hose assembly removed (para 3-4a)</p> <p>Material/Parts: Detergent, General Purpose (Item 1, App E) Wiping Rag (Item 2, App E) Determine additional materials required by hose size.</p>	<p>Hose Size</p> <p>1-in. Gasket (2) (Item 1, App I) Seal (4) (Item 5, App I) Strapping (AMR) (Item 6, App I)</p> <p>1 1/2-in..... Gasket (2) (Item 2, App I) Seal (4) (Item 5, App I) Strapping (A/R) (Item 6, App I)</p> <p>2-in. Gasket (2) (Item 3, App I) Seal (4) (Item 5, App I) Strapping (A/R) (Item 6, App I)</p> <p>4-in Gasket (2) (Item 4, App I) Seal (4) (Item 7, App I) Strapping (A/R) (Item 8, App I)</p>

NOTE

Ensure that all parts identified as mandatory replacement parts are discarded and replaced with new components. Disassemble hoses only to the level required to make repairs.

- a. Disassembly. Refer to figure 4-2.
 - (1) Disconnect split ring (1) from female coupling (2) and remove dust plug (3).
 - (2) Disconnect split ring (4) from male coupling (5) and remove dust cap (6).
 - (3) Remove gasket (7) from dust cap (6)
 - (4) Remove gasket (8) from female coupling (2).
 - (5) Cut strapping (clamps) (9 and 10) from hose (1). Pull female coupling (2) from hose.
 - (6) Cut strapping (clamps) (12 and 13) from hose (11). Pull male coupling (5) from hose
- b. Cleaning.
 - (1) Wash all components with clean water and detergent.
 - (2) Rinse components in clean water and dry with wiping rag.

4-14.- DISCHARGE AND SUCTION HOSE REPAIR - cont

- c. Inspection. Refer to figure 4-2
- (1) Inspect female coupling (2) and dust cap (6) for cracks, corrosion, and damaged locking arms.
 - (2) Inspect male coupling (5) and dust plug (3) for cracks and corrosion.
 - (3) Inspect hose (11) for cuts, tears, punctures, delamination.
- d. Repair. Replace damaged components. Do not reuse coupling gaskets (7 and 8) or strapping (9, 10, 12 and 13)

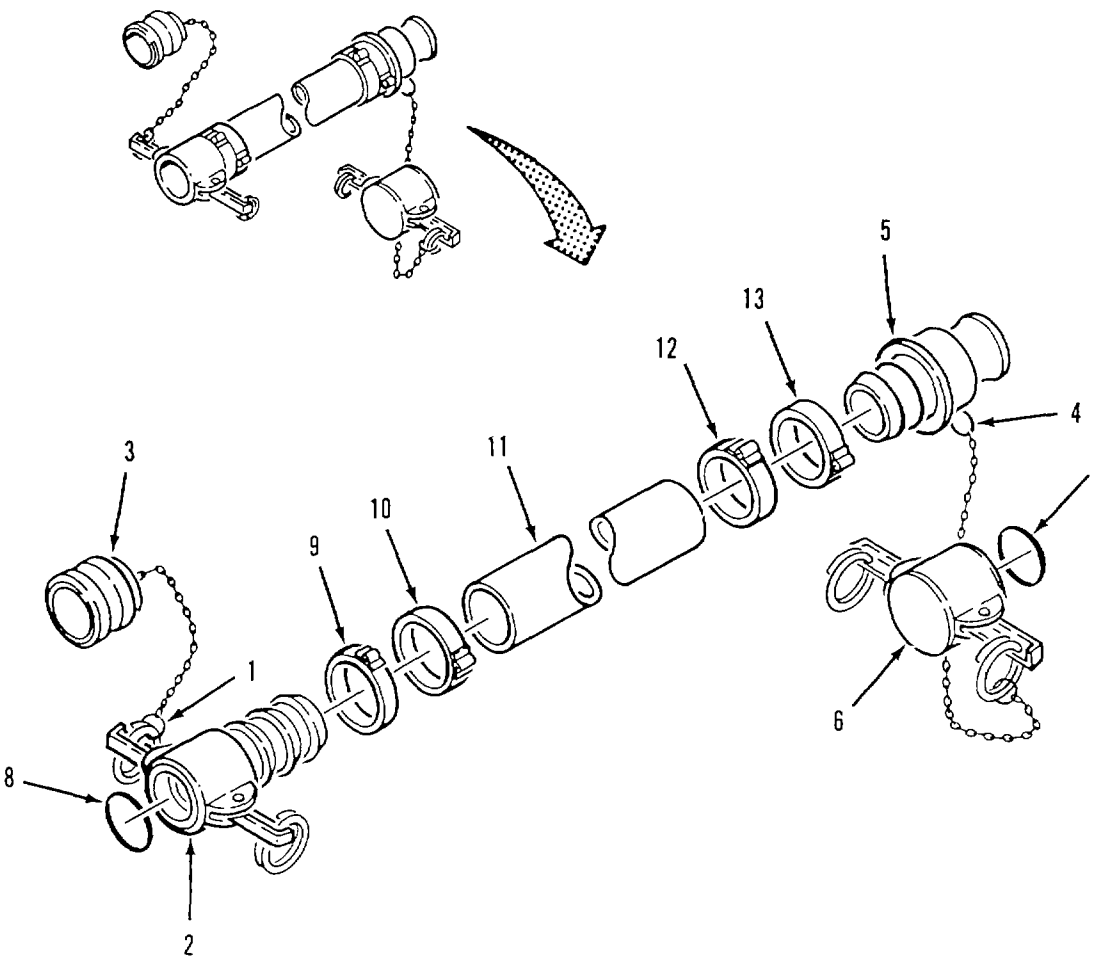

Figure 4-2. Discharge and Suction Hose Disassembly.

4-14. DISCHARGE AND SUCTION HOSE REPAIR - cont

e. Assembly.

- (1) Push male coupling (5, figure 4-2) and female coupling (2) into hose (11).

NOTE

Strapping and seals are supplied in the accessory kit

- (2) Cut a piece of strapping (1, figure 4-3) 36 inches long.
- (3) Slide seal (2) onto strapping (1) as shown Bend end of strapping under seal
- (4) Wrap other end of strapping (1) around hose (3) and through seal (2) Position strapping on hose about 1 inch from end of hose.
- (5) Wrap another loop of strapping (1) around hose (3) and through seal (2)
- (6) Position strapping (1) in slots of clamping tool (4) Tool nose(5) should fit snug against seal (2).
- (7) Apply pressure to gripper level (6) and turn handle (7) until strapping (1) is snug. Tool will lock in place when correct tension is applied Reposition tool as required.

CAUTION

Strapping can damage hose if over tightened-

- (8) Turn handle (7) clockwise to tighten strapping (1) Continue turning handle until strapping stops moving through seal (2)

CAUTION

Strapping may break if operator does not release tension on handle when bending over seal

- (9) While reversing handle (7) 3/4 turn, roll tool (4) to opposite side of seal (2). (This will bend strapping and prevent it from slipping through seal when tool is removed.)
- (10) Pull cutting handle (8) on tool to cut strapping (1).
- (11) Remove tool (4) while holding strapping stub down on seal (2) with thumb.
- (12) Clinch end of strapping (1) by hammering down tabs of seal (2) over strapping stub.
- (13) Repeat steps (2) through (12) for three remaining straps (10, 12, and 13). Straps should be 1-inch from end of hose and 1-inch apart.

4-14. DISCHARGE AND SUCTION HOSE REPAIR - cont

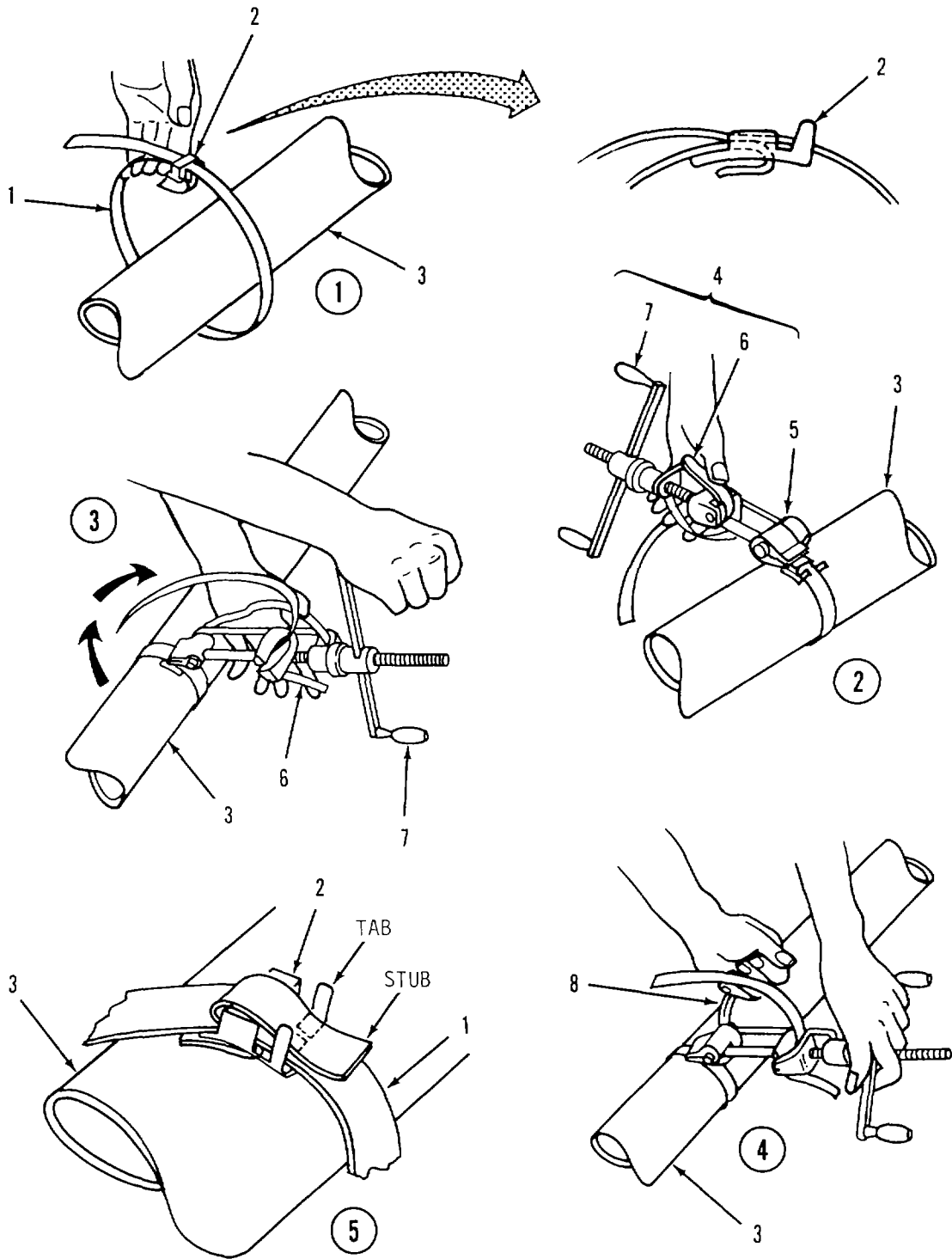

Figure 4-3. Strapping and Seal Installation.

4-14. DISCHARGE AND SUCTION HOSE REPAIR - cont**CAUTION**

Ensure gasket is fully seated in gasket seat of coupling/dust cap to prevent leaks in assembled components.

- (14) Install gasket (8, figure 4-4) in female coupling (2).
- (15) Install gasket (7) in dust cap (6).
- (16) Connect split ring (4) to male coupling (5). Install dust cap (6) on coupling.
- (17) Connect split ring (1) to female coupling (2). Install dust plug (3) on coupling
- (18) Install hose in water system (para 3-4b).
- (19) Startup water system (para 2-12c) and test repaired hose for leaks.

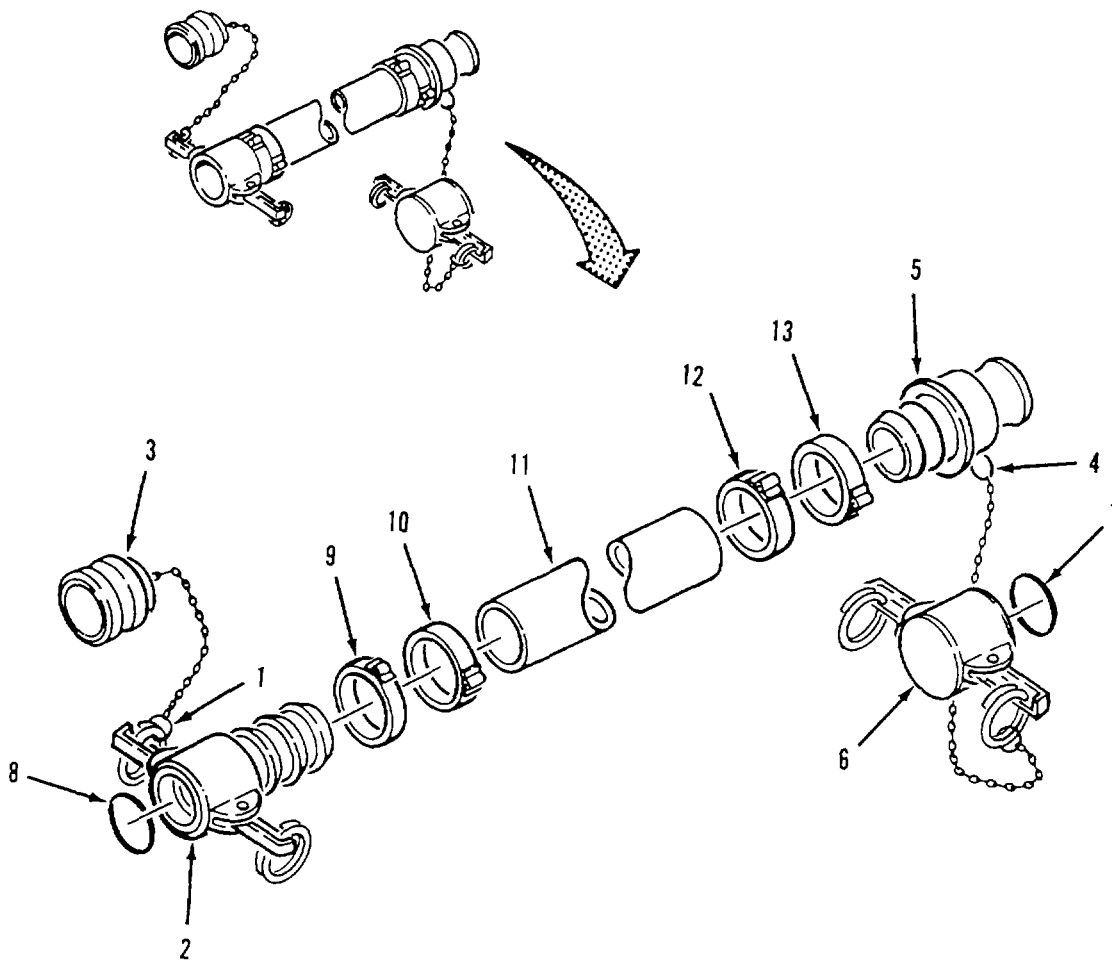

Figure 4-4. Discharge and Suction I-lose Assembly

4-15- GATE VALVE ASSEMBLY(2-INCH) REPAIR.
--

This task consists of: a. Disassembly b. Cleaning c. Inspection
 d. Repair e. Assembly

INITIAL SET-UP:	
<p>Tools: General Mechanics Tool Kit (Item 1, App B) Pipe Wrench (from accessory kit) Vice (Item 2, App B)</p> <p>Equipment Condition: Gate valve assembly removed (para 3-4a)</p>	<p>Material/Parts: Detergent, General Purpose (Item 1, App E) Wiping Rag (Item 2, App E) Tape, Anti-seize (Item 3, Appendix E) Coupling Gasket (Item 3, App I) Packing (Item 9, App I)</p>

NOTE

Ensure that all parts identified as mandatory replacement parts are discarded and replaced with new components.

a. Disassembly. Refer to figure 4-5.

- (1) Clamp gate valve body (13) in vise
- (2) Remove gasket (1) from female coupling (2)
- (3) Using pipe wrench, unscrew female coupling (2) from valve body (13).
- (4) Using pipe wrench, unscrew male coupling (3) from valve body (13).
- (5) Turn handwheel (5) fully clockwise to close valve.
- (6) Remove handwheel nut (4) and handwheel (5) from stem (11).
- (7) Using pipe wrench, remove bonnet ring (9) from valve body (13) Lift bonnet (10) and attached parts from valve body
- (8) Slide disc (12) from end of stem (11).
- (9) Unscrew packing nut (6) from bonnet (10).
- (10) Remove packing gland (7) and packing (8) from bonnet (10)
- (11) Unscrew stem (11) from bottom of bonnet (10).

b. Cleaning.

- (1) Wash all components with clean water and detergent.
- (2) Rinse components in clean water and dry with wiping rag

4-15. GATE VALVE ASSEMBLY(2-INCH) REPAIR - cont.

c. Inspection.

- (1) Inspect valve body (13) for cracks and stripped or damaged threads
- (2) Inspect disc (12) for cuts or scratches across sealing surfaces.
- (3) Inspect bonnet (10) for cracks and stripped threads.
- (4) Inspect stem (11) for stripped, galled or damaged threads
- (5) Inspect female coupling (2) for cracks, broken lock arms and damaged threads
- (6) Inspect male coupling (3) for cracks and damaged threads.

d. Repair. Replace all defective parts Do not reuse packing (8) or gasket (1). If disc (12) or valve body (13) is damaged, replace entire valve.

e. Assembly.

- (1) Screw stem (11) into bottom of bonnet (10).
- (2) Install new packing (8) and packing gland (7) over stem (11) and into bonnet (10).
- (3) Screw packing nut (6) onto bonnet (10) only finger tight.
- (4) Slide disc (12) onto end of stem (11).
- (5) Lower bonnet (10) and attached parts onto valve body (13). Make sure disc (12) fits in valve body seat
- (6) Install bonnet ring (9) on valve body (13). Tighten packing nut (7).
- (7) Install hand wheel (5) and handwheel nut (4) on stem (11).

NOTE

Ensure gasket is fully seated in groove of coupling.

- (8) Install gasket (1) in female coupling (2)

NOTE

Ensure that anti-seize tape is applied in the same direction as the threads.

- (9) Apply anti-seize tape to threads of female coupler (2). Using pipe wrench, screw coupler into valve body (13).
- (10) Apply anti-seize tape to threads of male coupler (3). Using pipe wrench, screw coupler (3) into valve body (13).
- (11) Install gate valve assembly in water system (para 3-4a).

4-15. GATE VALVE ASSEMBLY (2-INCH) REPAIR - cont.

- (12) Startup water system (para 2-12c) and check valve assembly for leaks. If valve leaks at stem (11), tighten packing nut (6) 1/4 turn until leak stops. Do not over tighten.

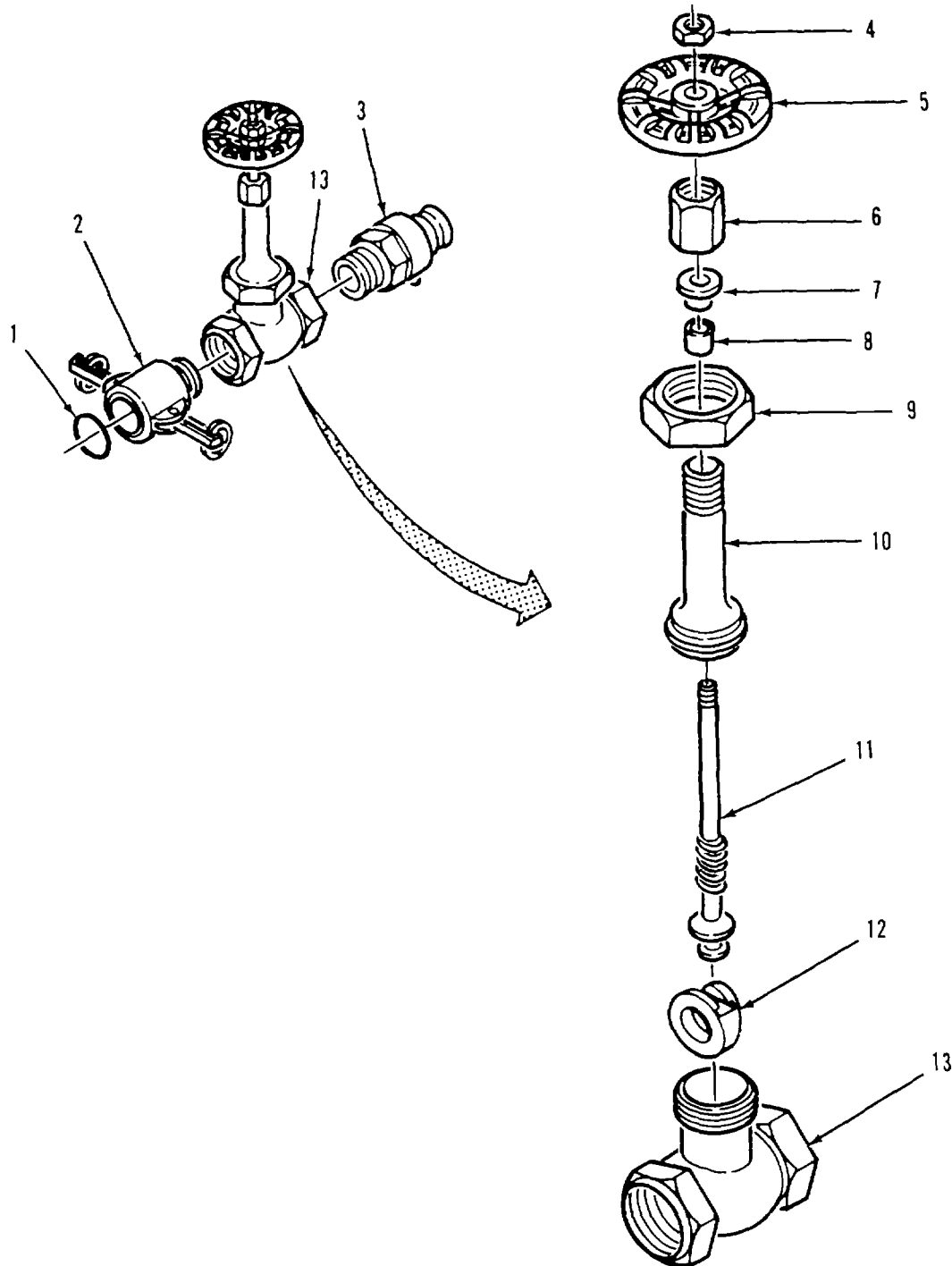

Figure 4-5. Gate Valve Assembly (2-inch) Repair.

4-16. TEE ASSEMBLY (9117-Y1) REPAIR.

This task consists of: a. Disassembly b. Cleaning c. Inspection
 d. Repair e. Assembly

INITIAL SET-UP:

<p>Tools: General Mechanics Tool Kit (Item 1, App B)</p> <p>Equipment Condition: Tee assembly removed (para 3-4a)</p> <p>Material/Parts: Detergent, General Purpose (Item 1, App E)</p>	<p>Wiping Rag (Item 2, App E) Tape, Anti-seize (Item 3, Appendix E) Gasket (2) (Item 4, App I) Gasket (3) (Item 10, App I) Lockwasher (24) (Item 11, App I)</p>
---	---

NOTE

Ensure that all parts identified as mandatory replacement parts are discarded and replaced with new components.

- a. Disassembly. Refer to figure 4-6.
 - (1) Disconnect ring (1) from female coupling (9) and remove plug (2).
 - (2) Remove gasket (3) from female coupling (9).
 - (3) Remove eight nuts (4), lock washer s (5), flat washers (6 and 8), and bolts (7).
 - (4) Separate female coupling (9) and gasket (10) from tee (28).
 - (5) Remove eight nuts (11), lockwashers (12), flat washers (13 and 15), and bolts (14).
 - (6) Separate male coupling (16) and gasket (17) from tee (28).
 - (7) Disconnect ring (18) from male coupling (26) and remove cap (20).
 - (8) Remove gasket (19) from cap (20).
 - (9) Remove eight nuts (21), lockwashers (22), flat washers (23 and 25), and bolts (24).
 - (10) Separate male coupling (26) and gasket (27) from tee (28).

- b. Cleaning
 - (1) Wash all components with clean water and detergent.
 - (2) Rinse components in clean water and dry with wiping rag.

4-16. TEE ASSEMBLY (9117-Y1) REPAIR - cont.

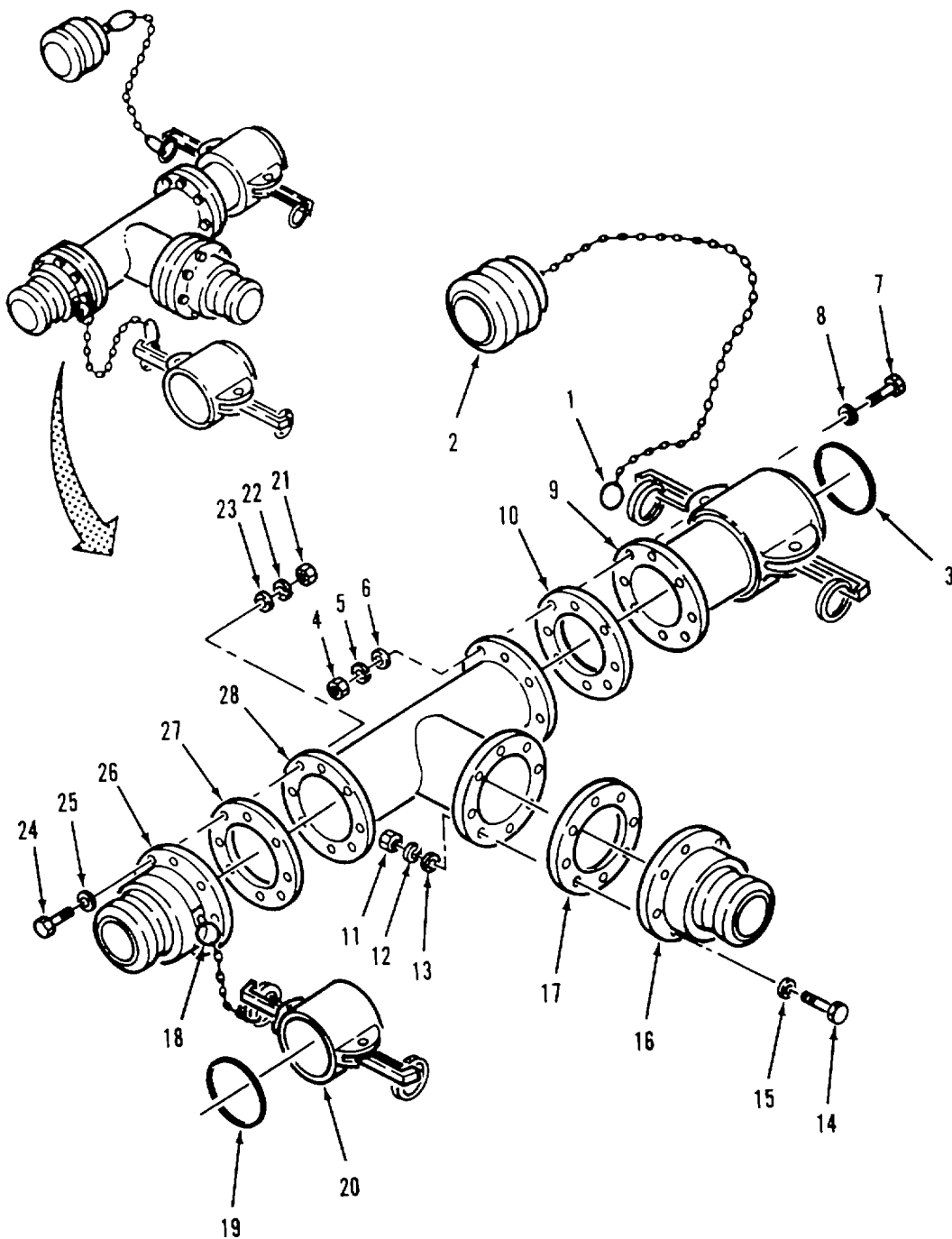

Figure 4-6. Tee Assembly (9117-Y1) Disassembly.

4-16. TEE ASSEMBLY (9117-Y1) REPAIR - cont.
--

- c. Inspection.
- (1) Inspect male couplings (16 and 26) for cracks.
 - (2) Inspect female coupling (9) for cracks and damaged lock arms.
 - (3) Inspect tee (28) for cracks and corrosion.
- d. Repair. Replace defective components. Do not reuse flange gaskets (10, 17 and 27) or gasket (3 and 19).
- e. Assembly. Refer to figure 4-7.
- (1) Position gasket (27) and male coupling (26) on tee (28)
 - (2) Install eight flat washers (23 and 25), bolts (24), lockwashers (22) and nuts (21).

NOTE

Ensure gasket is fully seated in groove of coupling.

- (1) Install gasket (19) in cap (20).
- (2) Connect cap (20) to male coupling (26) with ring (18).
- (3) Position gasket (17) and male coupling (16) on tee (28).
- (4) Install eight flat washers (13 and 15), bolts (14), lockwashers (12) and nuts (11).
- (5) Position gasket (10) and female coupling (9) on Tee (28).
- (6) Install eight flat washers (6 and 8), bolts (7), lockwasher-s (5) and nuts (4).

NOTE

Ensure gasket is fully seated in groove of coupling.

- (7) Install gasket (3) in female coupling (9).
- (8) Connect plug (2) to female coupling (9) with ring (1).
- (9) Connect tee assembly to water system (refer to para 2-8 to connect couplings).
- (10) Install tee assembly in water system (para 3-4a).
- (11) Startup water system (para 2-12c) and check tee assembly for leaks.

4-16. TEE ASSEMBLY (9117-Y1) REPAIR - cont.

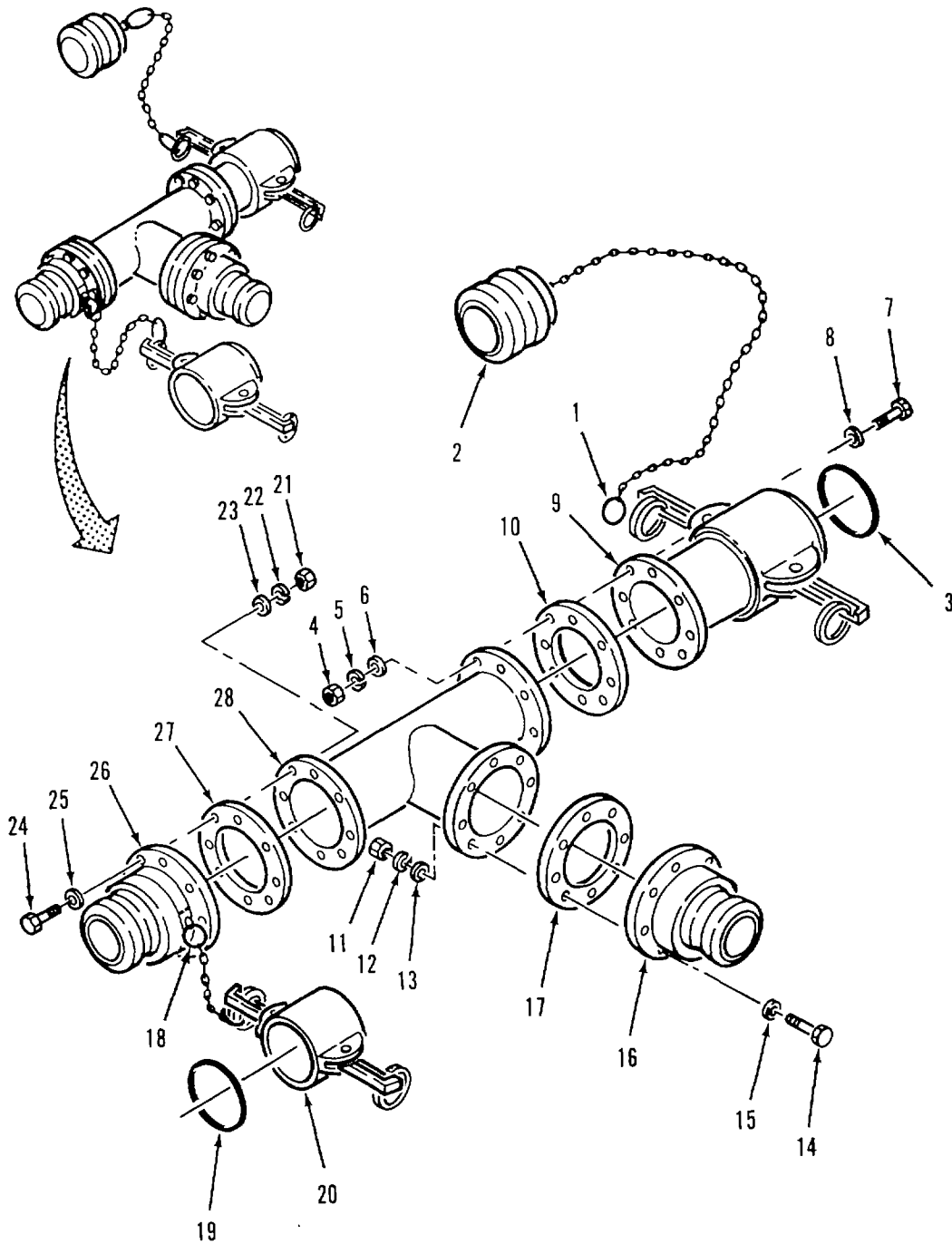

Figure 4-7. Tee Assembly (9117-Y1) Assembly.

4-17. DISTRIBUTION NOZZLE (1-INCH) REPAIR.

This task consists of: a. Disassembly b. Cleaning c. Inspection
 d. Repair e. Assembly

INITIAL SET-UP	
<p>Tools: General Mechanics Tool Kit (Item 1, App B) Vice (Item 2, App B)</p> <p>Equipment Condition: Distribution nozzle removed (para 3-4a)</p>	<p>Material/Parts Detergent, General Purpose (Item 1, App D) Rag, Wiping (Item 2, App D) Tape, Anti-seize (Item 3, App D) Gasket (Item 12, App I) Packing Ring (Item 13, App I) Disc (Item 14, App I)</p>

NOTE

Ensure that all parts identified as mandatory replacement parts are discarded and replaced with new components.

- a. Disassembly. Refer to figure 4-8.
 - (1) Disconnect S-hook (1) and remove cap (19) from chain (2).
 - (2) Disconnect S-hook (3) from body (18) and remove chain (2).
 - (3) Remove gasket (4) from coupling half(5).
 - (4) Remove swivel (6) and coupling half (5) from body (18).
 - (5) Unscrew coupling half (5) from swivel (6).

WARNING

To prevent injury to personnel, remove cap slowly. Spring tension may cause cap to fly off.

- (6) Remove cap (7) and spring (8) from body (18).
- (7) Remove disc holder (9), disc (10) and disc washer (11) from body (18).
- (8) Remove handle (12) from body (18).
- (9) Pull stem (13) out through top of body (18).
- (10) Remove packing nut (14) and packing (15) from body (18).
- (11) Loosen jam nut (16) Remove tube (17) and attached jam nut from body (18).

4-17. DISTRIBUTION NOZZLE (1-INCH) REPAIR - cont.

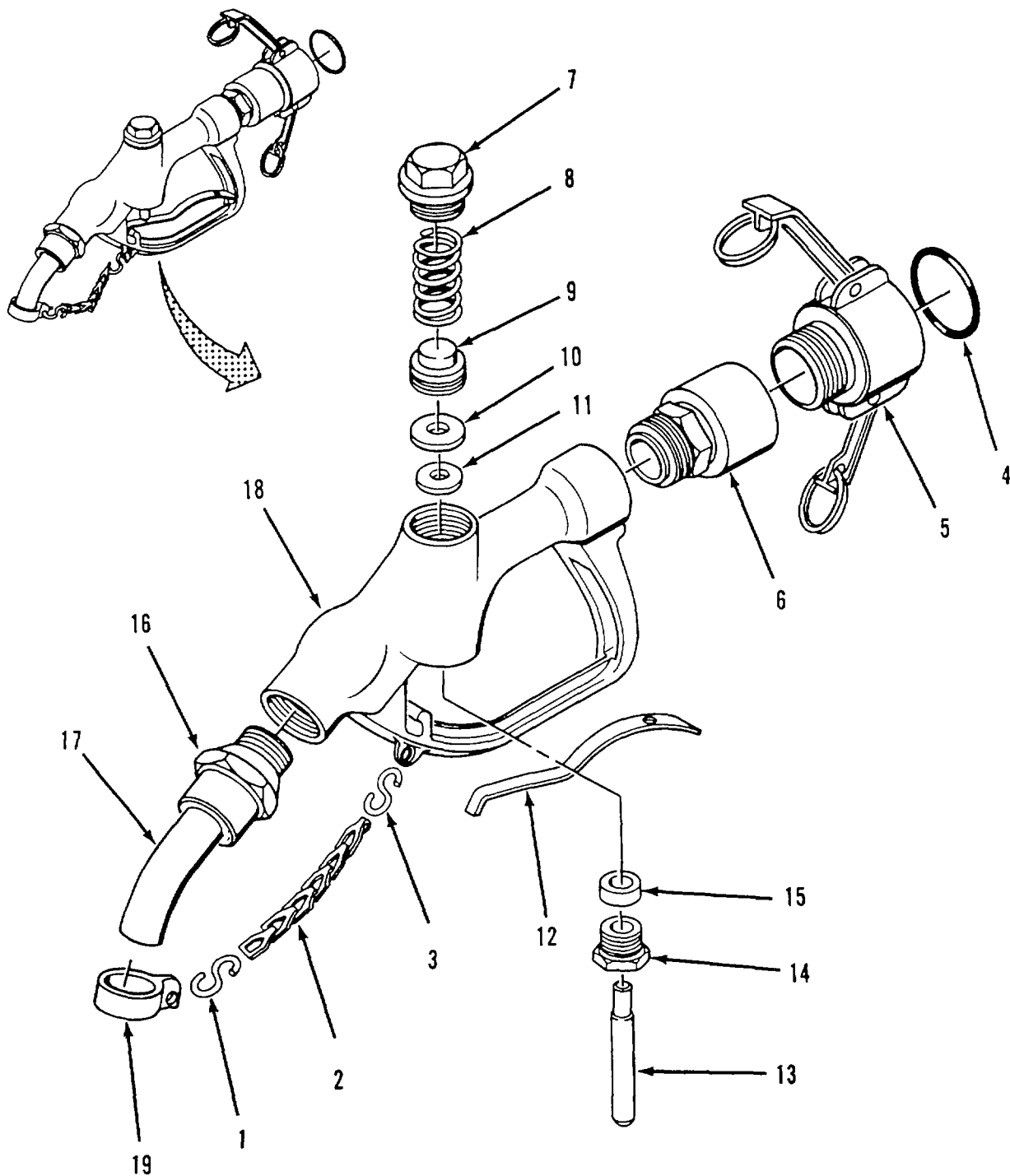

Figure 4-8. Distribution Nozzle (1-Inch) Disassembly.

4-17. DISTRIBUTION NOZZLE (1-INCH) REPAIR - cont.
--

- b. Cleaning.
 - (1) Wash all components with clean water and detergent.
 - (2) Rinse components in clean water and dry with wiping rag
- c. Inspection.
 - (1) Inspect body (18) and tube (17) for cracks and stripped or damaged threads.
 - (2) Inspect handle (12) for bends and cracks.
 - (3) Inspect stem (13) for scoring Check that stem is straight.
- d. Repair. Replace damaged parts Do not reuse gasket (4), packing (15) or disc (10).
- e. Assembly. Refer to figure 4-9.
 - (1) Position end of tube(17)on body (18)and secure with jam nut (16).
 - (2) Install packing (15) and packing nut (14) in body (18). Do not tighten packing nut.
 - (3) Push stem (13) into packing nut (14) from top of body (18) Make sure stem is positioned as shown.
 - (4) Position handle (12) in body (18). Push down on stem (13) to keep handle in place.
 - (5) Place disc washer (11), disc (10) and disc holder (9) on top of stem (13).
 - (6) Position spring (8) on top of disc holder (9) and install cap (7) on body (18).

NOTE

Ensure that anti-seize tape is applied in the same direction as the treads.

- (7) Apply anti-seize tape to male threads of coupling half(4) and swivel (6).
- (8) Install coupling half (5) on swivel (6).
- (9) Install swivel (6) and attached coupling half (5) onto body (18).

NOTE

Ensure gasket is fully seated in groove of coupling half.

- (10) Install gasket (4) in coupling half (5).
- (11) Connect chain (2) to body (18) with S-hook (3).
- (12) Connect cap (19) to chain (3) with S-hook (1).

4-17. DISTRIBUTION NOZZLE (1-INCH) REPAIR - cont.

- (13) Install distribution nozzle in water system (para 3-4a).
- (14) Startup water system (para 2-12c) and check distribution nozzle for leaks.

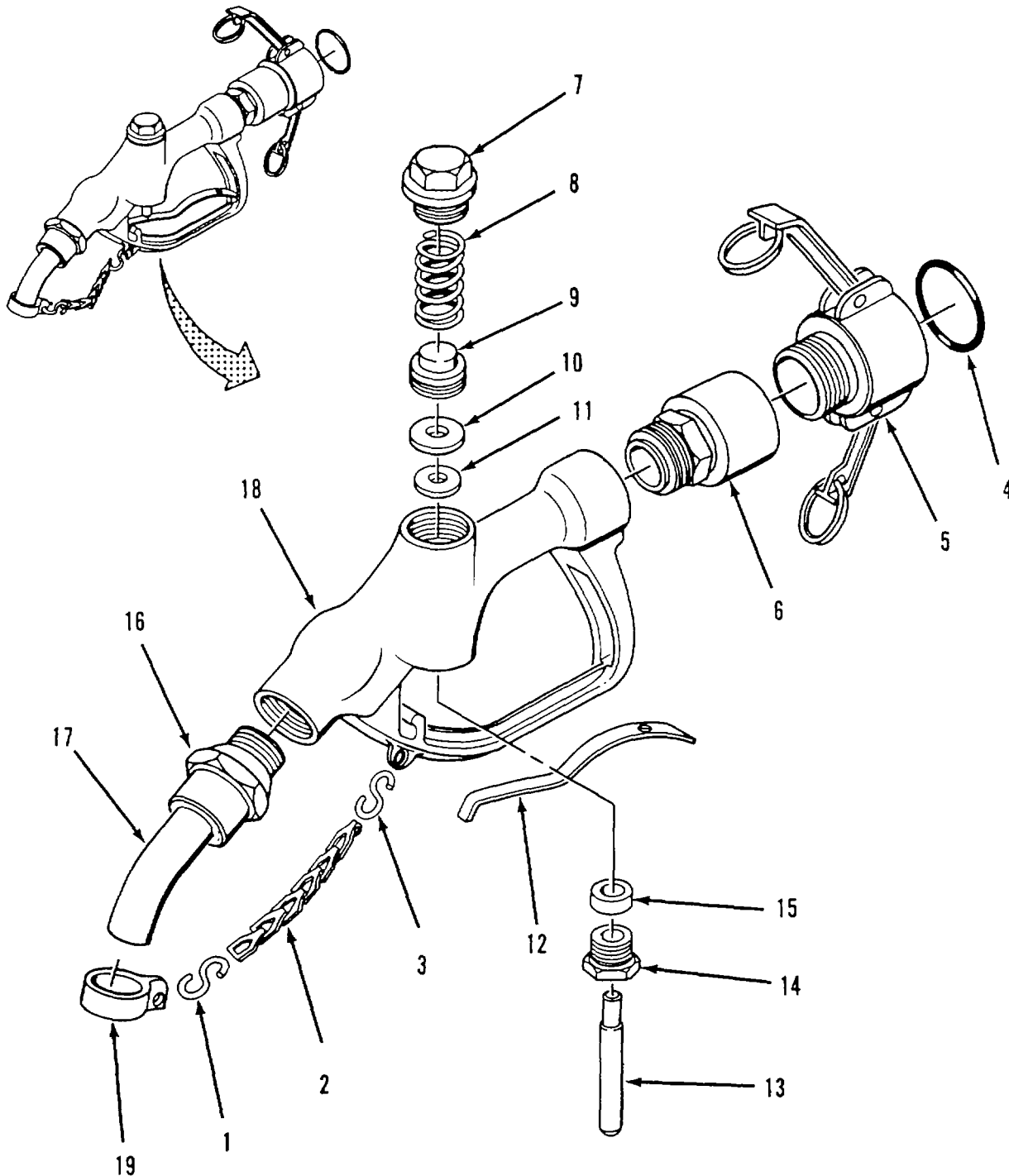

Figure 4-9. Distribution Nozzle (1-Inch) Assembly.

4-18. WATER PRESSURE REGULATOR ASSEMBLY REPAIR.

This task consists of:

a. Disassembly	b. Cleaning	c. Inspection
d. Repair	e. Assembly	f. Adjustment

INITIAL SET-UP:**Tools:**

General Mechanics Tool Kit (Item 1, App B)
Vice (Item 2, App B)

Equipment Condition:

Water pressure regulator removed (para 3-4a)

Material/Parts:

Detergent, General Purpose (Item 1, App E)
Wiping Rag (Item 2, App E)
Tape, Anti-seize (Item 3, Appendix E)
Diaphragm (Item 15, App I)
Gasket (2) (Item 16, App I)

NOTE

- Ensure that all parts identified as mandatory replacement parts are discarded and replaced with new components.
- Maximum operating pressure of the regulator is 400 psi Delivery pressure is 10-45 psi. Valve is set for 30 psi.

- a. Disassembly. Refer to figure 4-10.

Remove regulator assembly from mount. Refer to figure 4-10.

- (1) Remove four nuts (1) and washers (2).
- (2) Lift regulator assembly (3) from threaded rods (10).
- (3) Remove four washers (4) and nuts (5) from threaded rods (10).
- (4) Remove four nuts (6) and washers (7) from threaded rods (10).
- (5) Remove four threaded rods (10) and attached parts from board (11).
- (6) Remove washers (8) and nuts (9) from each threaded rod (10).
- (7) Place regulator assembly (3) in vice.
- (8) Disconnect ring (12) and remove plug (13) from female coupling (15).
- (9) Remove gasket (14) from female coupling (15).
- (10) Remove female coupling (15), coupling (16) and nipple (17) from regulator assembly (3).
- (11) Disconnect ring (18) from male coupling (21) and remove cap (20).
- (12) Remove gasket (19) from cap (20).
- (13) Remove male coupling (21) from regulator assembly (3).

4-18. WATER PRESSURE REGULATOR ASSEMBLY REPAIR - cont.

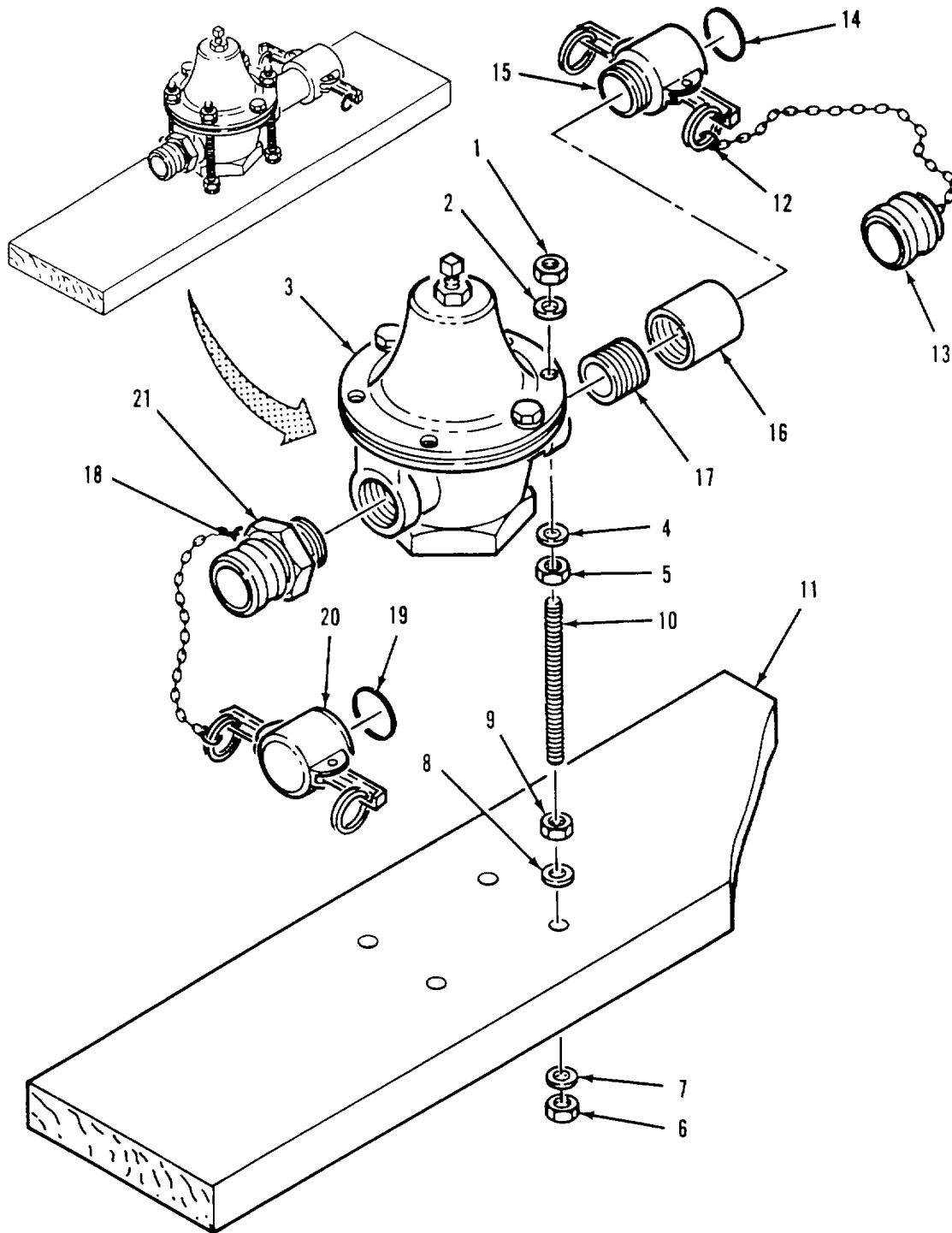

Figure 4-10. Water Pressure Regulator Disassembly.

4-18. WATER PRESSURE REGULATOR ASSEMBLY REPAIR - cont.

Disassemble Regulator Assembly Refer to figure 4-1.

- (14) Loosen locknut (2).
- (15) Remove adjusting screw (1), locknut (2), and tag (3) from spring chamber (6).
- (16) Mark and record location, then remove two nuts (4) and screws (5).
- (17) Lift spring chamber (6) from body (18).
- (18) Remove spring button (7) and pressure spring (8) from top of pressure plate (9).

NOTES

- Pressure plate is not secured to diaphragm.
 - Diaphragm consists of four metal discs.
- (19) Remove pressure plate (9) and diaphragm (10) from body (18). If pressure plate and diaphragm are stuck together, gently pry them apart.
 - (20) Remove button (11) from body (18).
 - (21) Position body (18) so that plug (12) is pointing up.

NOTE

Plug is under light spring tension.

- (22) Loosen plug (12) with wrench and unscrew from body (18) by hand.
- (23) Remove gasket (13) from plug (12).
- (24) Remove strainer screen (16), piston (15), and spring (14) from body (18).
- (25) Remove cylinder (17) from body (18).

b. Cleaning.

- (1) Wash all components with clean water and detergent.
- (2) Rinse components in clean water and dry with wiping rag.

c. Inspection.

- (1) Inspect spring chamber (6) and body (18) for cracks, stripped threads, and corrosion.
- (2) Inspect diaphragm (10) for cuts, tears, and holes.
- (3) Inspect strainer screen (16) for tears and clogs.
- (4) Inspect cylinder (17) and piston (15) for scoring, abrasion and corrosion.
- (5) Inspect springs (8 and 14) for broken or stretched coils.

4-18. WATER PRESSURE REGULATOR ASSEMBLY REPAIR - cont.

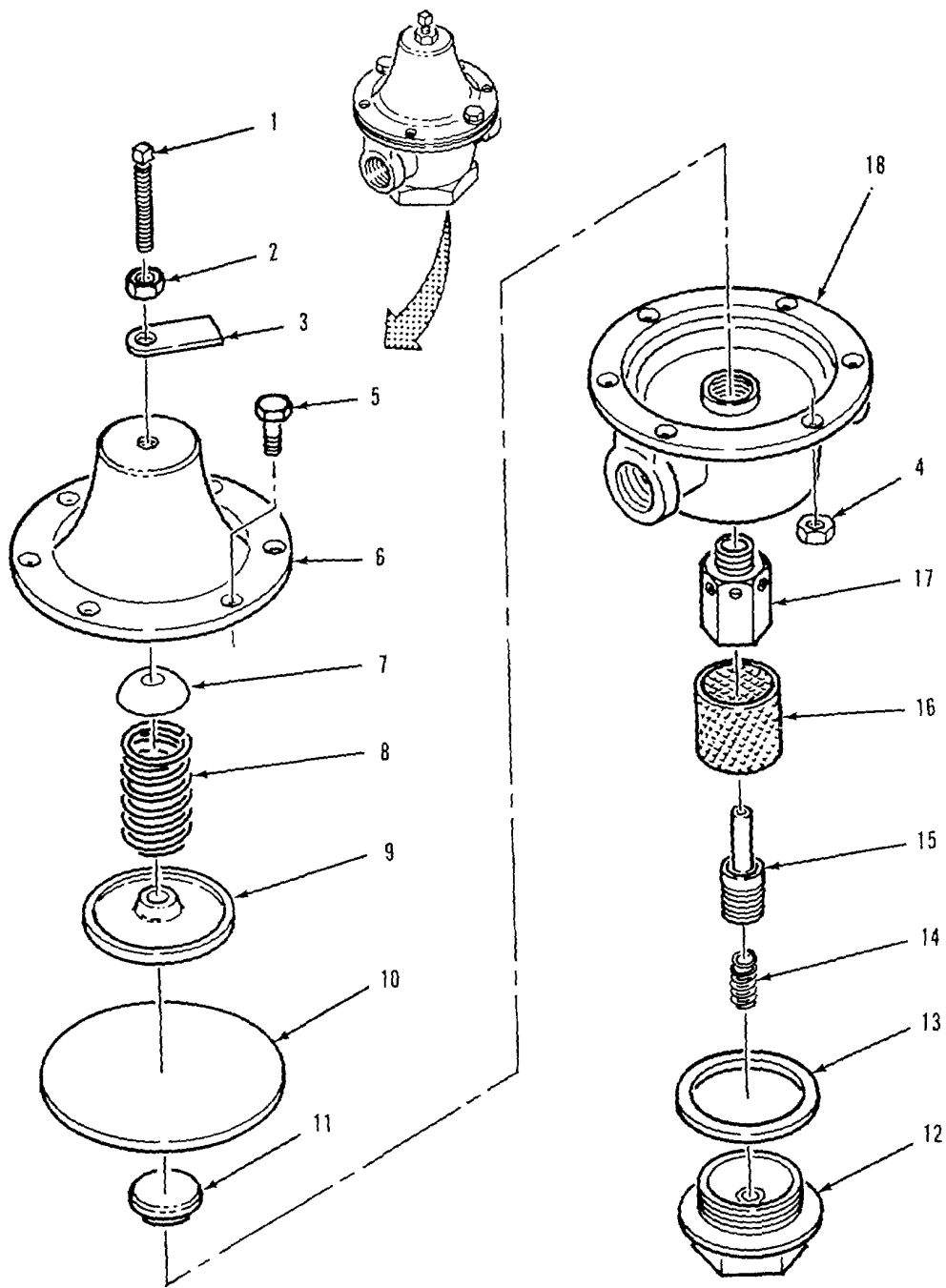

Figure 4-11. Water Pressure Regulator Repair.

4-18. WATER PRESSURE REGULATOR ASSEMBLY REPAIR - cont.

- d. Repair. Replace worn damaged parts and all sealing components. If piston (29) or cylinder (27) is worn, replace both components.
- e. Assembly.

Assemble regulator assembly. Refer to figure 4-17.

- (1) Install gasket(13) on plug (12).
- (2) Position body(18) so that opening for plug (11) is pointing up.
- (3) Install cylinder (17) in body(18).
- (4) Position strainer screen (16) over cylinder (17), then install piston (15), and spring (14) in cylinder.
- (5) Screw plug(12) into body (18). Make sure parts fit into body correctly.
- (6) Turn body (18) over so that plug (12) is pointing down. Position button (11) on post of piston (15) sticking up through cylinder (17). Make sure button is centered on piston.

NOTE

Diaphragm consists of four metal discs.

- (7) Position diaphragm (10) and pressure plate (9) on body (18).
- (8) Position pressure spring (8) and spring button (7) on pressure plate (9).
- (9) Lower spring chamber (6) onto body (18). Make sure pressure plate (9), spring (8), and spring button (7) remain centered on diaphragm (10).
- (10) Install two screws (5) and nuts (4) in body (18) and spring chamber (6). Screws must be installed in holes marked during removal.
- (11) Install tag (3), locknut (2) and adjusting screw (1).

Install regulator assembly on mount. Refer to figure 4-10.

- (12) Apply anti-seize tape to threads of male coupling (21). Install coupling on regulator assembly (3).

NOTES

Ensure gasket is fully seated in groove of coupling cap.

- (13) Install gasket (19) in cap (20).
- (14) Connect cap (20) and attached chain to male coupling (21) with ring (18).

4-18. WATER PRESSURE REGULATOR ASSEMBLY REPAIR - cont.**NOTE**

- Ensure gasket is fully seated in groove of coupling.
- (15) Install gasket (14) in female coupling (15).

NOTES

- Ensure that anti-seize tape is applied in the same direction as the treads.
 - Ensure female coupling is installed on side of regulator marked "INLET".
- (16) Apply anti-seize tape to threads of female coupling (15) and nipple (17). Install female coupling(15) on nipple (16). Install nipple and attached coupling on inlet side of regulator assembly (3).
- (17) Install one nut (9) and washer (8) on each of four threaded rods (10).
- (18) Position four threaded rods (10) and attached parts on board (11).

NOTE

Rods should extended through bottom of board about 1/4-inch.

- (19) Install threaded rods (10) on board (11) with four washers (7) and nuts (6). Adjust position of nuts (6 and 9) on threaded rods so that rods extends about 1/4-inch below board.
- (20) Install four nuts (5) and washers (10) on threaded rods (10).
- (21) Lower regulator assembly (3) onto threaded rods (10).
- (22) Install four washers (2) and nuts (1) on threaded rods (10).
- (23) Position four nuts (5) and washers (4) against bottom of regulator assembly (3), then tighten four nuts (1).
- f. Adjust. Refer to figure 4-12.
- (1) Install regulator assembly in water system (hose and nozzle kit) (para 3-4a).
- (2) Startup water system (para 2-12c) and check regulator assembly for leaks.
- (3) Squeeze distribution nozzle control lever (para 2-2) and allow water to flow.
- (4) If water flow at distribution nozzle is not at desired pressure, loosen locknut (1) on regulator assembly (3).

NOTE

Positioning adjusting screw so that seven threads are exposed above the locknut will provide a good starting point for further adjustment.

- (5) Turn adjusting (2) to the left to reduce water pressure or to the right to increase water pressure.

4-18. WATER PRESSURE REGULATOR ASSEMBLY REPAIR - cont.

- (6) When pressure is adjusted correctly, tighten locknut (1).
- (7) Release distribution nozzle control lever.

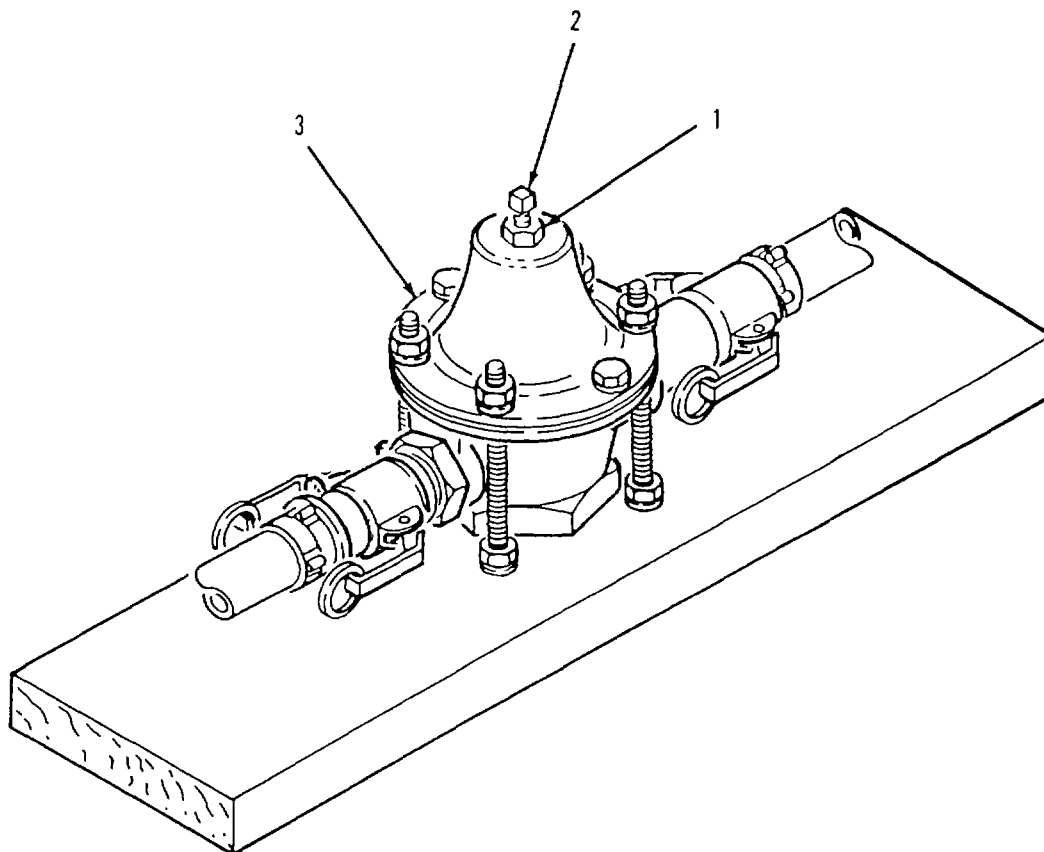

Figure 4-12. Water Pressure Regulator Adjustment.

4-19. NOZZLE STAND ASSEMBLY REPAIR.

This task consists of: a. Disassembly b. Cleaning c. Inspection
 d. Repair e. Assembly

INITIAL SET-UP**Tools:**

General Mechanics Tool Kit (Item 1, App B)

Material/PartsDetergent, General Purpose (Item 1, App F1)
Wiping Rag (Item 2, App E)
Cotter Pin (2) (Item 17, App I)**NOTE**

Ensure that all parts identified as mandatory replacement parts are discarded and replaced with new components.

- a. Disassembly. Refer to figure 4-13.
 - (1) Unbend and remove S-hooks (1, 3 and 5) and disconnect chains (2, 4 and 6).
 - (2) Remove cotter pin (7) and straight pin (8), then remove leg (11) from leg (13).
 - (3) Remove cotter pin (10) and straight pin (9), then remove leg (12) from leg (13).
- b. Cleaning.
 - (1) Wash all components with clean water and detergent.
 - (2) Rinse components in clean water and dry with wiping rag.
- c. Inspection. Refer to figure 4-13.
 - (1) Inspect legs (11, 12 and 13) for cracks, broken clevis ends and bent or missing nozzle hangers.
 - (2) Inspect chains (2, 4 and 6) for broken links.
- d. Repair. Replace defective components.
- e. Assembly. Refer to figure 4-13.
 - (1) Position clevis fitting on leg (12) over pivot fitting on leg (13).
 - (2) Install straight pin (9) through pivot fitting and clevis. Install cotter pin (10) in straight pin
 - (3) Aline clevis fitting on leg (13) with pivot fitting on leg (1).
 - (4) Install straight pin (8). Install cotter pin (7) in straight pin.
 - (5) Connect chains (2, 4, and 6) to legs (11, 12, and 13) with S-hooks (1, 3 and 5).

4-19. NOZZLE STAND ASSEMBLY REPAIR.

(6) Position nozzle stand in water system.

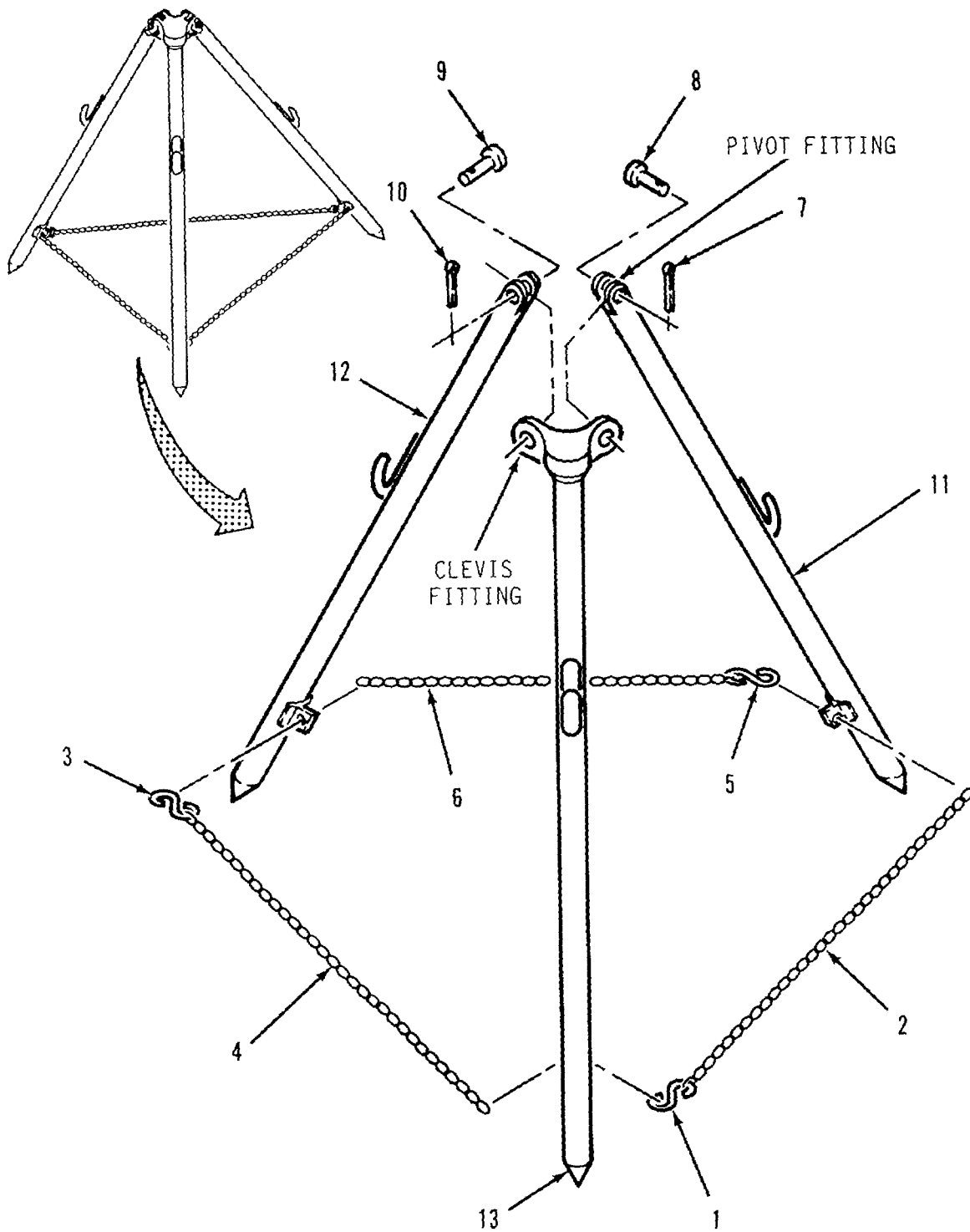

Figure 4-13. Nozzle Stand Repair.

4-20. HOSE NOZZLE KIT MAINTENANCE.

The hose nozzle kit consists of the components listed below. Refer to the following paragraphs for applicable maintenance procedures.

Procedure	Para.
Discharge hose Assembly Repair.....	4-14
Gate Valve Assembly (2-inch) Repair.....	4-15
Tee Assembly (9117-Y1) Repair.....	4-16
Nozzle Stand Assembly Repair	4-19
Distribution Nozzle Assembly (1-1/2 inch)	4-21

4-21. DISTRIBUTION NOZZLE (1 1/2-INCH) REPAIR.

This task consists of:

a. Disassembly	b. Cleaning	c. Inspection
d. Repair	e. Assembly	

INITIAL SET-UP:	
<p>Tools: General Mechanics Tool Kit (Item 1, App B) Vice (Item 2, App B)</p> <p>Equipment Condition: Gate valve assembly removed (para 3-4a)</p>	<p>Material/Parts: Detergent, General Purpose (Item 1, App E) Wiping Rag (Item 2, App E) Tape, Anti-seize (Item 3, Appendix E) Gasket (Item 2, App I) Packing (Item 18, App I) Disc (Item 19, App I) Disc (Item 20, App I)</p>

NOTE

Ensure that all parts identified as mandatory replacement parts are discarded and replaced with new components

- a. Disassembly. Refer- to figure 4-14.
 - (1) Disconnect S-hook (1) from body (26).
 - (2) Remove S-hook (1) from chain and spring (2).
 - (3) Remove tube cap (4) and S-hook (3) from chain and spring (2). Disconnect S-hook from tube cap.
 - (4) Remove gasket (5) from female coupling (6).
 - (5) Remove swivel (7) and female coupling (6) from body (26).
 - (6) Unscrew female coupling (6) from swivel (7).
 - (7) Drive out groove pin (8) and remove handle (9) from body (26).

4-21. DISTRIBUTION NOZZLE (1 1/2-INCH) REPAIR.**WARNING**

To prevent injury to personnel, remove cap slowly. Spring may be under tension.

- (8) Remove cap (10), gasket (11), spring (12) from body (26).
- (9) Remove assembled components (13,14 and 15) from body (26).
- (10) Unscrew disc guide (15) from disc holder (13) and remove small disc (14).
- (11) Lift assembled components (16 through 19) from body (26).
- (12) Unscrew disc nut (16) from holder (17), then remove washer (18) and disc (19) from holder.
- (13) Loosen packing nut (20) and pull stem (23) from body (26).
- (14) Remove packing nut (20) and packing gland (21) from body (26).
- (15) Remove stuffing box (24) from body (26).
- (16) Remove packing (22) from bottom of stuffing box (24).
- (17) Unscrew tube and adapter (25) from body (26).

b. Cleaning.

- (1) Wash all components with clean water and detergent.
- (2) Rinse components in clean water and dry with wiping rag.

c. Inspection.

- (1) Inspect body (26) for cracks and stripped or damaged threads.
- (2) Inspect handle (9) for cracks.
- (3) Inspect tube and adapter (25) for bends, cracks, and deformation.
- (4) Inspect stem (23) for scoring. Check that stem is straight.

d. Repair. Replace damaged parts and all sealing components.**e. Assembly. Refer to figure 4-15.**

- (1) Screw tube and adapter (25) into body (26).
- (2) Install packing (22) in stuffing box (24), then screw stuffing box down into body (26).

4-21. DISTRIBUTION NOZZLE (1 1/2-INCH) REPAIR - cont.

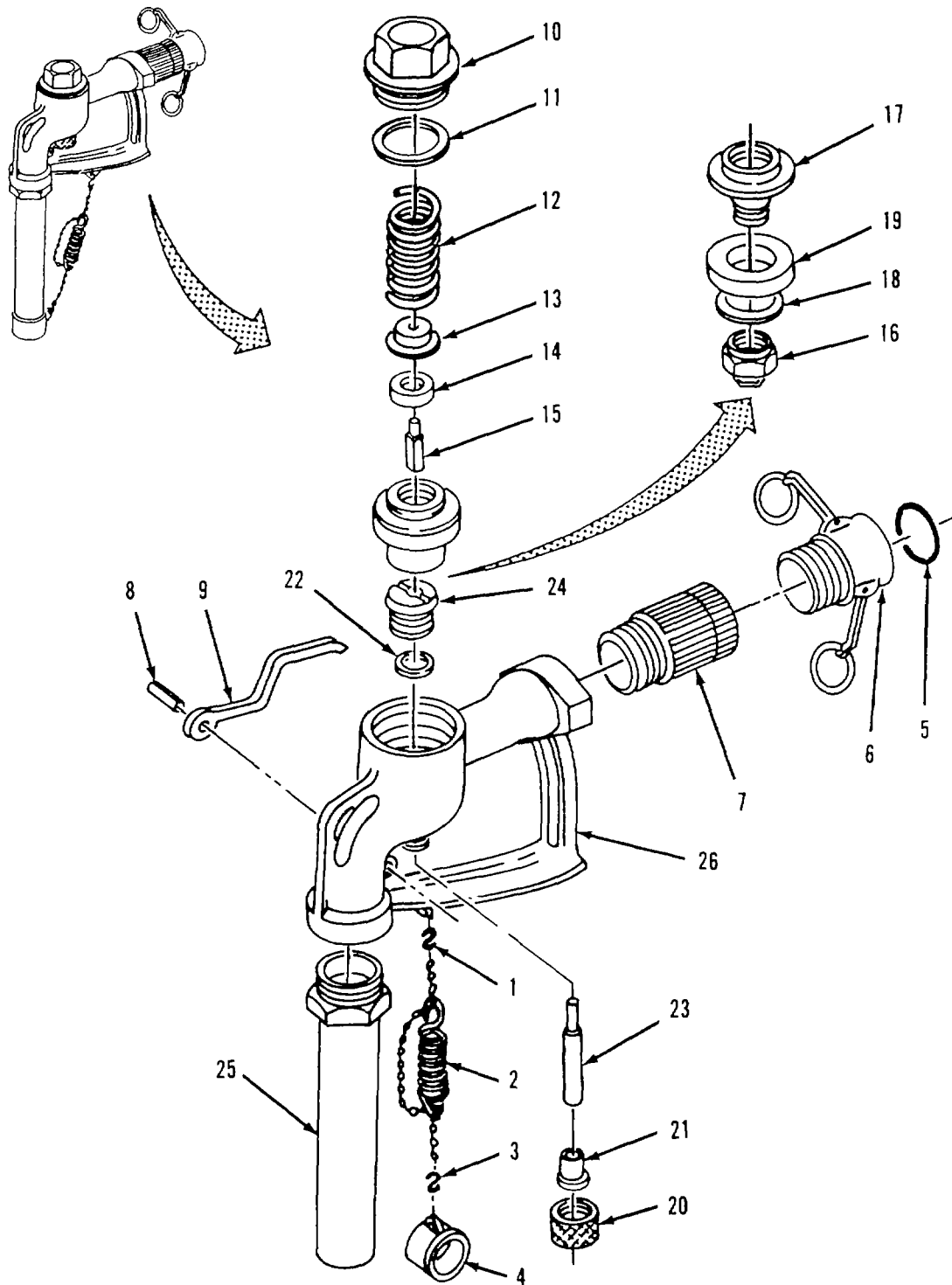

Figure 4-14. Distribution Nozzle (1 1/2-inch) Disassembly.

4-21. DISTRIBUTION NOZZLE (1 1/2-INCH) REPAIR - cont.

- (3) Push stem (23) in through body (26) and into stuffing box (24).
- (4) Place packing gland (21) and packing nut (20) over stem (23). Tighten packing gland onto body (26).
- (5) Position disc (19) and washer (18) on holder (17). Screw disc nut (16) into holder (17).
- (6) Position assembled components (16 through 19) in body (26).
- (7) Position small disc (14) on disc holder (13). Screw disc guide (15) into disc holder
- (8) Position assembled components (13,14 and 15) in body (26).

NOTE

Ensure that anti-seize tape is applied in the same direction as the treads.

- (9) Apply anti-seize tape to threads of cap (10).
- (10) Install gasket (11) on cap (10).
- (11) Position spring (12) on top of disc holder (13).
- (12) Install cap (10) over spring (12) and onto body (26).
- (13) Position handle (9) on body (26) and install groove pin (8).
- (14) Apply anti-seize tape to male threads of swivel (7) and female coupling (6).
- (15) Screw female coupling (6) into swivel (7).
- (16) Screw swivel (7) and attached female coupling (6) onto body (26).
- (17) Install gasket (5) in female coupling (6).
- (18) Connect tube cap (4) to chain and spring (2) with S-hook (3).
- (19) Connect chain and spring (2) to body (26) with S-hook (1).

4-21. DISTRIBUTION NOZZLE (1 1/2-INCH) REPAIR - cont.

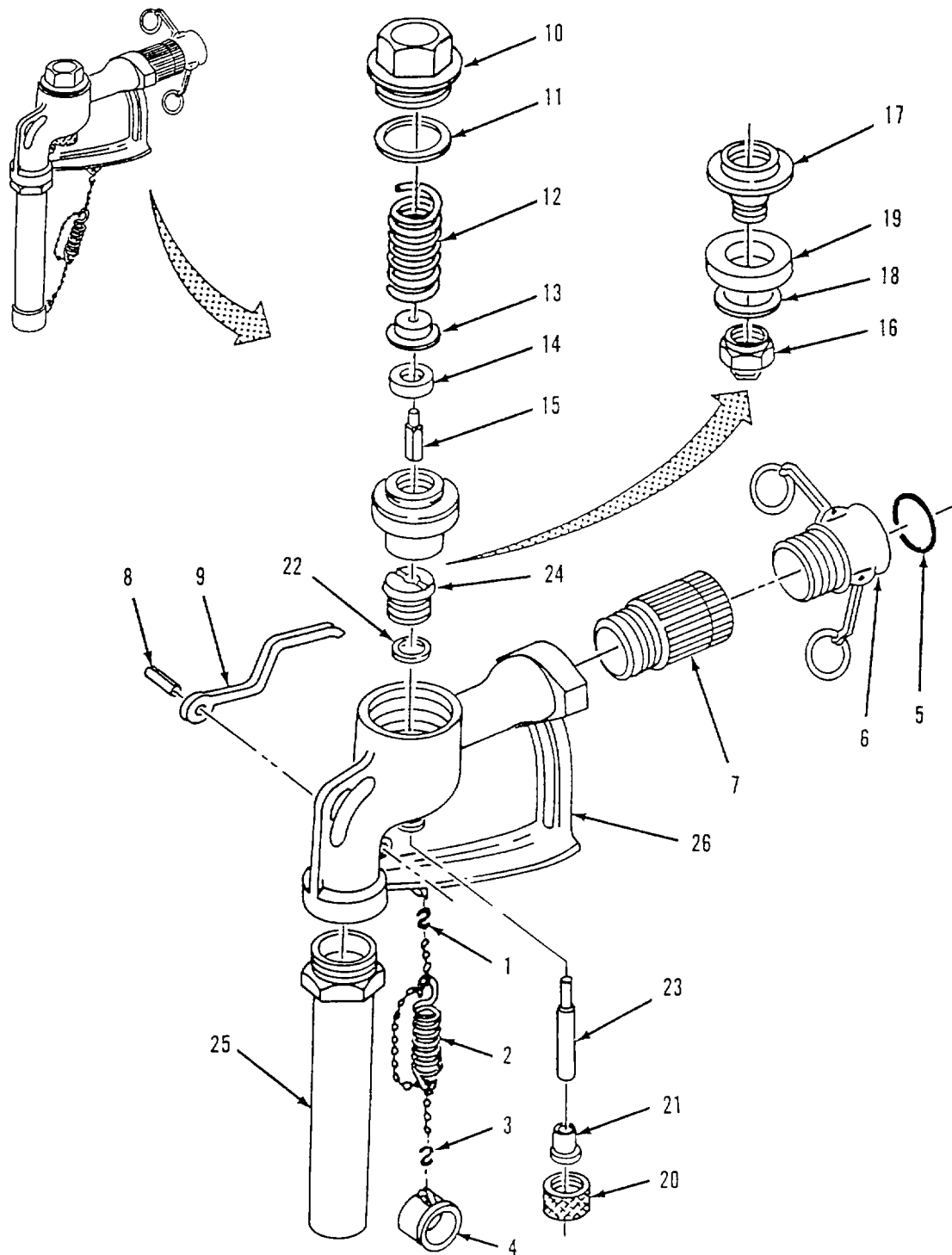

Figure 4-15. Distribution Nozzle (1 1/2-Inch) Assembly.

4-22. 2-INCH HOSE CONNECTION KIT MAINTENANCE.

The 2-inch hose connection kit consists of the components listed below. Refer to the following paragraphs for applicable maintenance procedures.

Procedure	Para.
Discharge Hose Repair	4-14
Gate Valve Assembly (2-Inch) Repair	4-15
Tee Assembly (9117-Y1) Repair.....	4-16
Nozzle Stand Assembly Repair	4-19
Distribution Nozzle (1-1/2 Inch)	4-21

4-23. 4-INCH HOSE CONNECTION KIT MAINTENANCE.

The 4-inch hose connection kit consists of the components listed below. Refer to the following paragraphs for applicable maintenance procedures.

Procedure	Para.
Butterfly Valve Assembly Repair	4-24
Discharge Hose Repair	4-14
Quick Acting Valve Assembly Repair	4-25
Tee Assembly (91 17-Y1) Repair.....	4-16
Tee and Gate Valve Assembly (9133-Y1) Repair (Model 800KWSDS).....	4-25.1
Nozzle Stand Assembly Repair	4-19

4-24. BUTTERFLY VALVE ASSEMBLY REPAIR.

- This task consists of:
- | | | |
|----------------|-------------|---------------|
| a. Disassembly | b. Cleaning | c. Inspection |
| d. Repair | e. Assembly | |

INITIAL SET-UP:	
Tools: General Mechanics Tool Kit (Item 1, App. B)	Gasket (2) (Item 10, App I)
Equipment Condition: Butterfly valve assembly removed (para 3-4a)	Seal (Item 21, App I)
Material/Parts: Corrosion Preventive Compound (Item 4, App E)	Seal (Item 22, App I)
Detergent, General Purpose (Item 1, App E)	O-ring (2) (Item 23, App I)
Wiping Rag (Item 2, App E)	Bearing, Top (Item 24, App I)
Gasket (2) (Item 4, App I)	Bearing, Bottom (Item 25, App I)
	Sleeve (Item 26, App I)
	Pin, Cotter (Item 27, App I)

NOTE

Ensure that all parts identified as mandatory replacement parts are discarded and replaced with new components.

- a. Disassembly.

Butterfly valve removal. Refer to figure 4-16.

4-24. BUTTERFLY VALVE ASSEMBLY REPAIR - cont.

- (1) Disconnect ring (1) and remove cap (3) from male coupling (7).
- (2) Remove gasket (2) from cap (3).

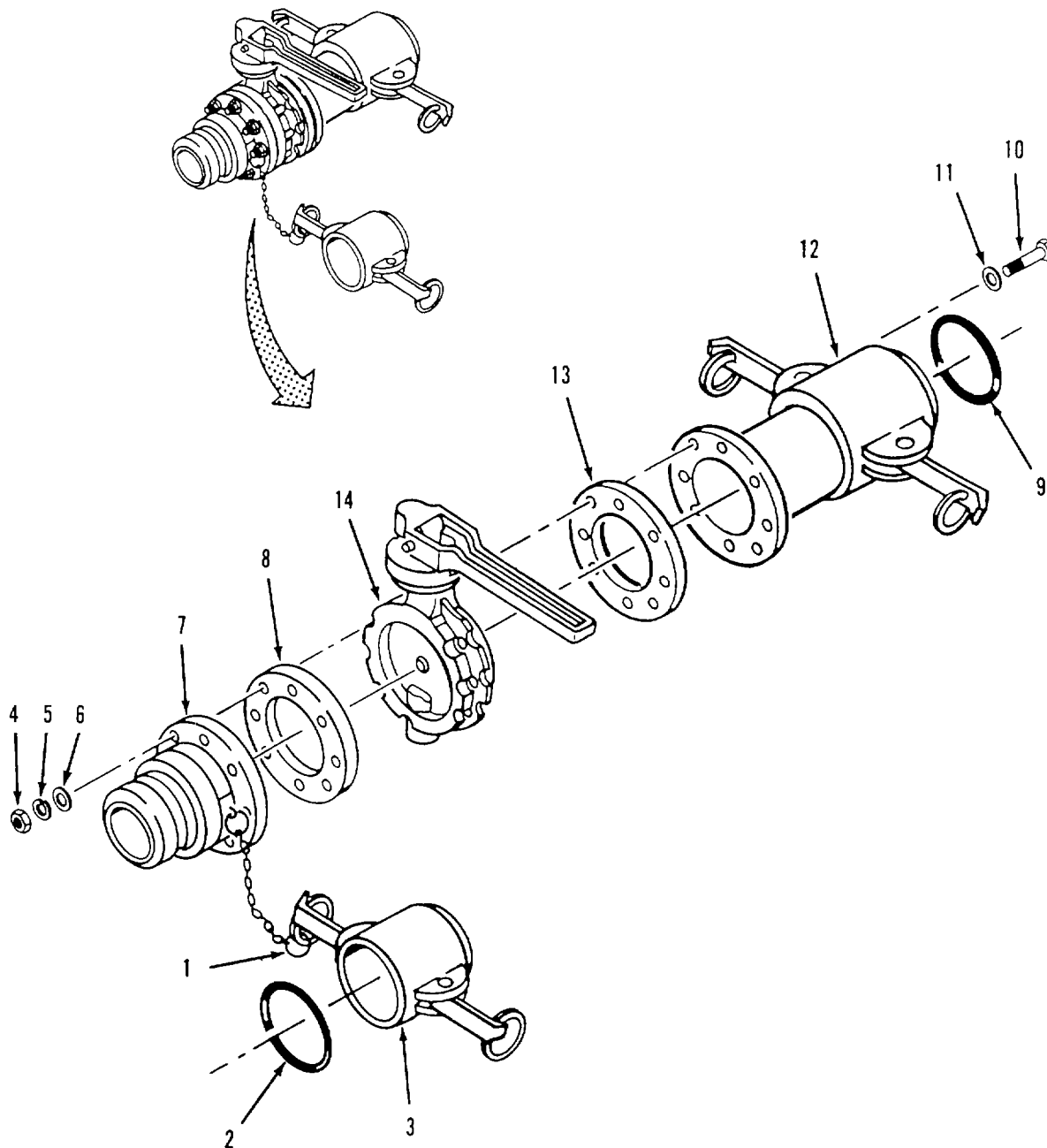

Figure 4-16. Butterfly Valve Disassembly.

4-24. BUTTERFLY VALVE ASSEMBLY REPAIR - cont.

- (3) Remove eight nuts (4), lockwashers (5), flat washers (6 and 11) and screws (10).
- (4) Remove male coupling (7) and gasket (8) from butterfly valve (14).
- (5) Remove female coupling (12) and gasket (13) from butterfly valve (14).
- (6) Remove gasket (9) from female coupling (12).

Butterfly valve disassembly. Refer to figure 4-17.

- (7) Remove cotter pin (1) and pin (2) from handle (3). Lift handle and attached spring (4) from stem (8).
- (8) Remove two socket head screws (5) and stop plate (6) from body (19).
- (9) Remove top seal (7) from bottom of stop plate (6).
- (10) Pull to extract top stem (8) and attached parts from body (19).
- (11) Remove seal (9), o-ring (10), top bearing (12) and o-ring (11) from top stem (8).
- (12) Using punch, drive out spring pin (13) from body (19) and bottom stem (14).
- (13) Pull bottom stem (14) and attached parts from body (19).
- (14) Remove bottom bearing (15) and o-ring (16) from bottom stem (14).
- (15) Push disc (17) from body (19).
- (16) Remove sleeve (18) from body (19).

b. Cleaning.

- (1) Wash all components with clean water and detergent.
- (2) Rinse components in clean water and dry with wiping rag.

c. Inspection.

- (1) Inspect male coupling (7, figure 4-16), female coupling (12) and cap (3) for cracks and corrosion.
- (2) Inspect body (19, figure 4-17), handle (3), disc (17) and stop plate (6) for cracks and corrosion.
- (3) Inspect top stem (8) and bottom stem (14) for cracks, deep scratches and corrosion.

d. Repair. Replace damaged parts and all sealing components.

4-24. BUTTERFLY VALVE ASSEMBLY REPAIR - cont.

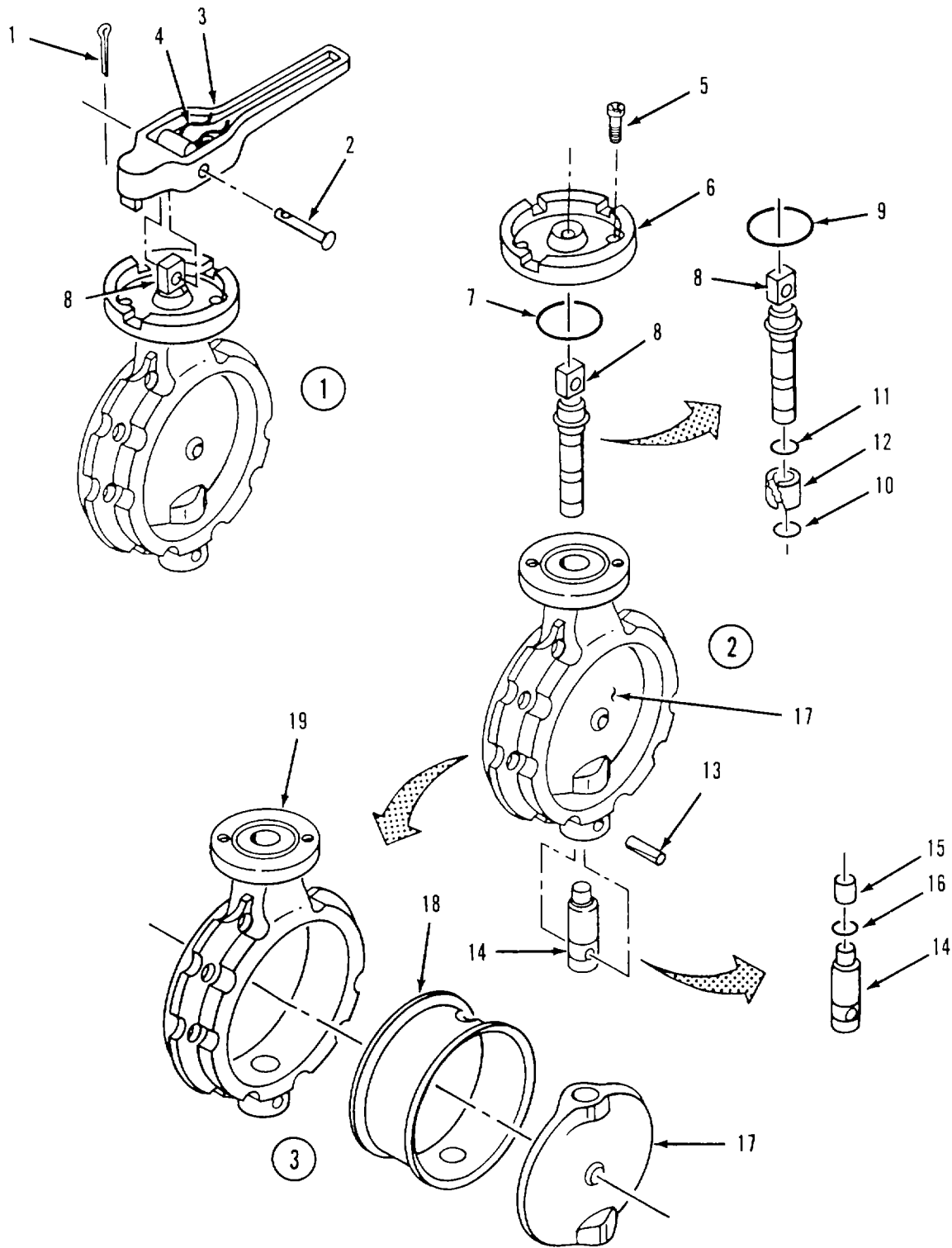

Figure 4-17. Butterfly Valve Repair.

4-24. BUTTERFLY VALVE ASSEMBLY REPAIR - cont.
--

e. Assembly.

Butterfly valve assembly. Refer to figure 4-17.

- (1) Install sleeve (18) in body (19). Aline holes in sleeve with holes in body (19).

NOTE

Bottom hole in disc is round and smooth. Top hole is slotted to fit on end of top stem.

- (2) Push disc (17) into body (19) Aline holes in top and bottom of disc with holes in sleeve (18) and body (19).
- (3) Install o-ring (16) and bottom bearing (15) on bottom stem (14).
- (4) Push bottom stem (14) in through bottom of body (19) and into bottom hole in disc (17). Aline spring pin hole in stem with spring pin hole in body.
- (5) Using punch, drive spring pin (13) into body (19) and through bottom stem (14).
- (6) Install o-ring (11), top bearing (12) and o-ring (10) on bottom of top stem (8).
- (7) Install seal (9) on top of top stem (8).
- (8) Aline end of top stem (8) with hole in disc (17). Push stem and attached parts through body (19) and into slot in disc (17). Make sure stem is fully seated in disc.
- (9) Install top seal (7) in bottom of stop plate (6).
- (10) Position stop plate (6) on body (19) and install two socket head screws (5).
- (11) Rotate disc (17) to open position.
- (12) Position handle (3) and attached spring (4) on top stem (8) so that handle is in line with disc (17).

NOTE

Press handle down against spring to aline holes with top stem.

- (13) Install pin (2) through handle (3) and top stem (8). Secure pin with cotter pin (1).

Butterfly valve installation. Refer to figure 4-16.

NOTE

Make sure gasket is fully seated in coupling groove.

- (14) Install gasket (9) in female coupling (12).

4-24. BUTTERFLY VALVE ASSEMBLY REPAIR - cont.

(15) Position gasket (13) and female coupling (12) on butterfly valve (14).

(16) Position gasket (8) and male coupling (7) on butterfly valve (14).

NOTE

Tighten nuts evenly in a cross pattern.

(17) Install eight flat washers (11), screws (10), flat washers (6), lockwashers (5) and nuts (4).

(18) Connect cap (3) to male coupling (7) with ring (1).

NOTE

Make sure gasket is fully seated in cap.

(19) Install gasket (2) in cap (3).

4-25. QUICK ACTING VALVE ASSEMBLY REPAIR.

This task consists of:	a. Disassembly d. Repair	b. Cleaning e. Assembly	c. Inspection
------------------------	-----------------------------	----------------------------	---------------

INITIAL SET-UP:

<p>Tools: General Mechanics Tool Kit (Item 1, App B) Pipe Wrench (from accessory kit) Vice (Item 2, App B)</p> <p>Equipment Condition: Quick acting valve assembly removed (para 3-4a)</p> <p>Material/Parts: Detergent, General Purpose (Item 1, App E)</p>	<p>Rag, Wiping (Item 2, App E) Tape, Anti-seize (Item 3, Appendix E) Gasket (Item 4, App I) Packing (2) (Item 34, App I) Gasket (2) (Item 35, App I) Seat (2) (Item 36, App I) Lock washer (8) (Item 37, App I) Locking nut (Item 38, App I)</p>
--	---

NOTE

Ensure that all parts identified as mandatory replacement parts are discarded and replaced with new components.

- a. Disassembly. Refer to figure 4-18.
 - (1) Place quick acting valve (4) in vice.
 - (2) Turn handle (16) to the closed position.
 - (3) Remove gasket (1) from female coupling (2).
 - (4) Remove female coupling (2) from valve (4).
 - (5) Remove male coupling (3) from valve (4).

4-25. QUICK ACTING VALVE ASSEMBLY REPAIR.

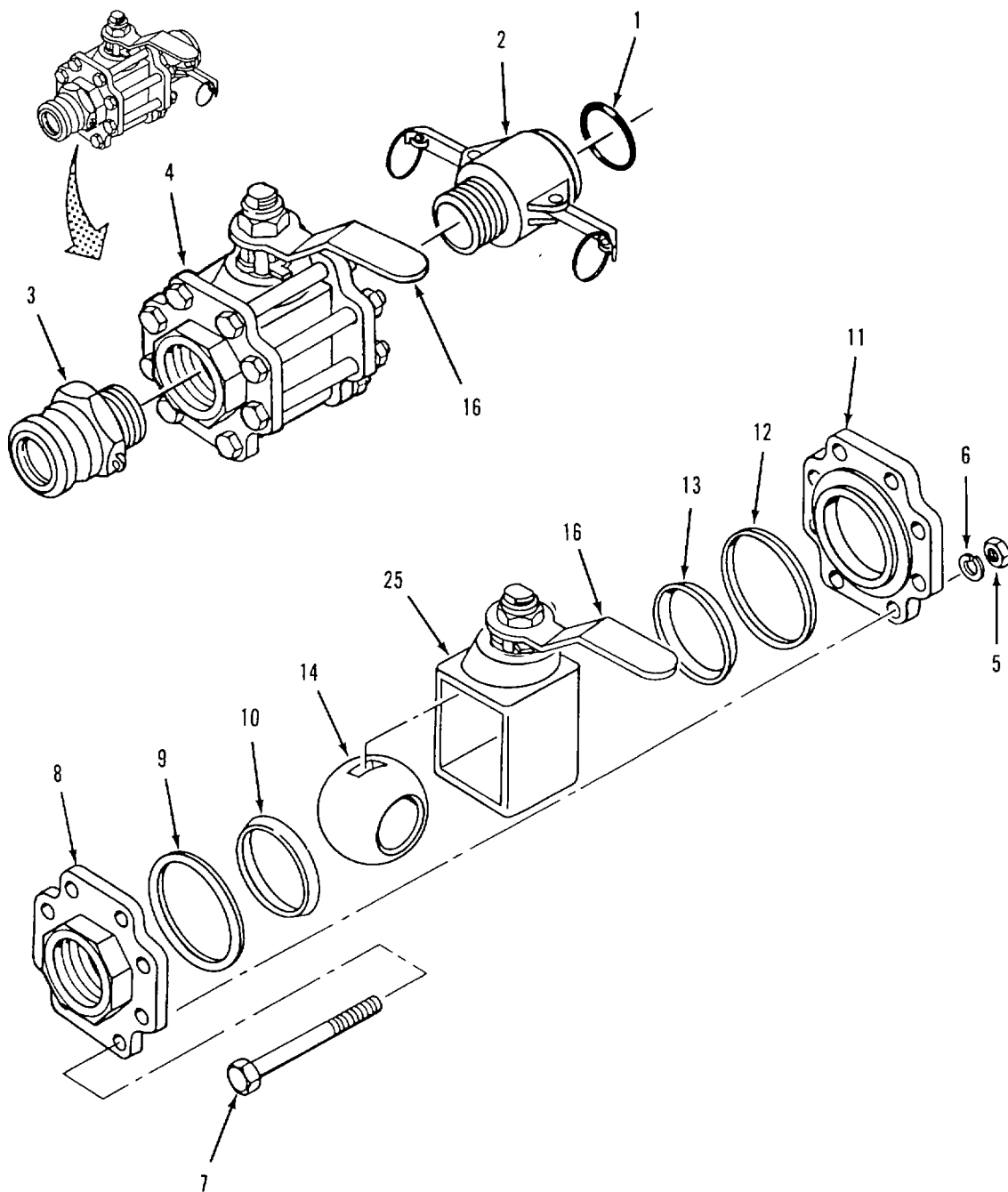

Figure 4-18. Quick Acting Valve Repair (Sheet 1 of 2).

4-25. QUICK ACTING VALVE ASSEMBLY REPAIR - cont.

- (6) Remove eight nuts (5), lockwashers (6), and bolts (7).
- (7) Separate end fitting (8) from body (25).
- (8) Remove body gasket (9) and seat (10) from end fitting (8).

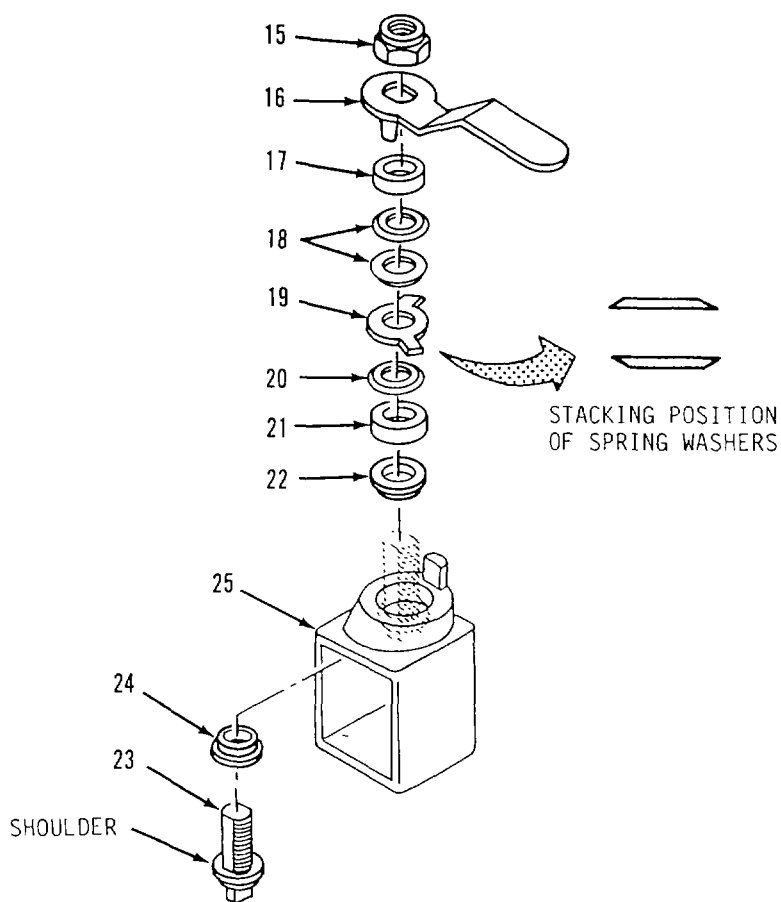

Figure 4-18. Quick Acting Valve Repair (Sheet 2 of 2)-

4-25. QUICK ACTING VALVE ASSEMBLY REPAIR - cont.

- (9) Separate end fitting (11) from body (25).
- (10) Remove body gasket (12) and seat (13) from end fitting (11).
- (11) Carefully slide ball (14) front body (24). Use care not to scratch or nick surface of ball.
- (12) Remove locking nut (15) and handle (16) from stem (23).
- (13) Remove spacer (17), two spring washers (18), follower (19) and spring washer (20) from stem (23).
- (14) Push stem (23) down into body (25) and remove.
- (15) Remove spacer (21) and packing (22) from top of body (25).
- (16) Remove packing (24) from inside body (25).

b. Cleaning.

- (1) Wash all components with clean water and detergent.
- (2) Rinse components in clean water and dry with wiping rag.

c. Inspection.

- (1) Inspect ball (14) for scratches, nicks and badly worn areas.
- (2) Inspect body (25), end fittings (8 and 11) and handle (16) for cracks and corrosion.
- (3) Inspect stem (23) and male coupling (3) for damaged threads and corrosion.
- (4) Inspect female coupling (2) for damaged threads, cracks, corrosion and damaged locking arms.

d. Repair. Replace damaged parts and all sealing components.**e. Assembly.**

- (1) Position packing (24) on stem (23). Push packing down onto stem until seated on shoulder at bottom of stem.
- (2) Push stem (23) and attached packing (24) into stem mounting hole inside body (25).
- (3) While supporting stem (23), install packing (22) over stem and press into top of body (25).
- (4) Slide spacer (21) onto stem (23) until seated on top of packing (22).
- (5) Install spring washer (20) and follower (19) over stem (23).
- (6) Install two spring washers (19) over stem (23). Make sure spring washers are stacked as shown.

4-25. QUICK ACTING VALVE ASSEMBLY REPAIR - cont.

- (7) Install spacer (17) on stem (23).
- (8) Install handle (16) and locking nut (15) on stem (23). Tighten locking nut only enough to draw parts together.
- (9) Set handle (16) to closed position.
- (10) Carefully slide ball (14) into body (25). Groove in ball must engage bottom of stem (23).
- (11) Install body gasket (12) and seat (13) on end fitting (11).
- (12) Install body gasket (9) and seat (10) on end fitting (8).
- (13) Position end fittings (8 and 11) on body (25).
- (14) Install eight bolts (7) and lockwashers (6). Screw nuts (5) onto bolts until hand tight.

CAUTION

Gap between end plates and body is normal. Do not attempt to close this gap by over-tightening the nuts. Internal seats could be damaged and handle will be very difficult to turn.

- (15) Using a cross pattern, tighten eight nuts (5) one turn.
- (16) Rotate handle (16) to open position, then back to closed position. Handle movement should be firm, but not tight or loose.
- (17) Repeat steps (14) and (15) until force required to move handle (16) is correct.
- (18) Tighten locking nut (15) until spring washers (18 and 20) are fully compressed, then back off nut 1/4 turn.
- (19) Rotate handle (16) to open position, then back to closed position. Pressure required to move handle should have increased, but handle should not be tight.

NOTE

Ensure that anti-seize tape is applied in the same direction as the threads.

- (20) Apply anti-seize tape to male threads of male coupling (3) and female coupling (2).
- (21) Screw female coupling (2) and male coupling (3) into valve (4).

NOTE

Ensure gasket is fully seated in groove of coupling.

- (22) Install gasket (1) in female coupling (2).
- (23) Install quick acting valve in water system (para 3-4a).
- (24) Startup water system (para 2-12c) and check valve for leaks and proper operation.

4-25.1. QUICK ACTING VALVE ASSEMBLY REPAIR - cont.

This task consists of:

a. Disassembly	b. Cleaning	c. Inspection
d. Repair	e. Assembly	

INITIAL SET-UP:	
Tools: General Mechanics Tool Kit (Item 1, App. B) Vice (Item 2, App. B)	Material/Parts: Detergent, General Purpose (Item 1, App. E) Wiping Rag (Item 2, App. E) Gasket (2) (Item 4, App. I) Gasket (4) (Item 10, App. I) Lockwashers (32) (Item 11, App. I)
Equipment Condition: Tee and dual gate valve assembly removed (para. 3-4a)	

NOTE

Ensure that all parts identified as mandatory replacement parts are discarded and replaced with new components.

- a. Disassembly. Refer to figure 4-18.1.
- (1) Remove eight nuts (1), lockwashers (2), flat washers (3), screws (4) and ten flat washers (5).
 - (2) Separate male coupling (6) and gasket (7) from gate valve (13).
 - (3) Remove eight nuts (8), lockwashers (9), flat washers (10), screws (11) and ten flat washers (12).
 - (4) Separate gate valve (13) and gasket (14) from tee (35).
 - (5) Disconnect ring (15) from female coupling (23) and remove plug (16).
 - (6) Remove gasket (17) from female coupling (23).
 - (7) Remove eight nuts (18), lockwashers (19), flat washers (20), screws (21), and flat washers (22).
 - (8) Separate female coupling (23) and gasket (24) from gate tee (35).
 - (9) Disconnect ring (25) from male coupling (33) and remove cap (26).
 - (10) Remove gasket (27) from cap (26).
 - (11) Remove eight nuts (28), lockwashers (29), flat washers (30), screws (31), and flat washers (32).
 - (12) Separate male coupling (33) and gasket (34) from tee (35).

4-25A. TEE AND GATE VALVE ASSEMBLY (9133-Y1) REPAIR - cont.

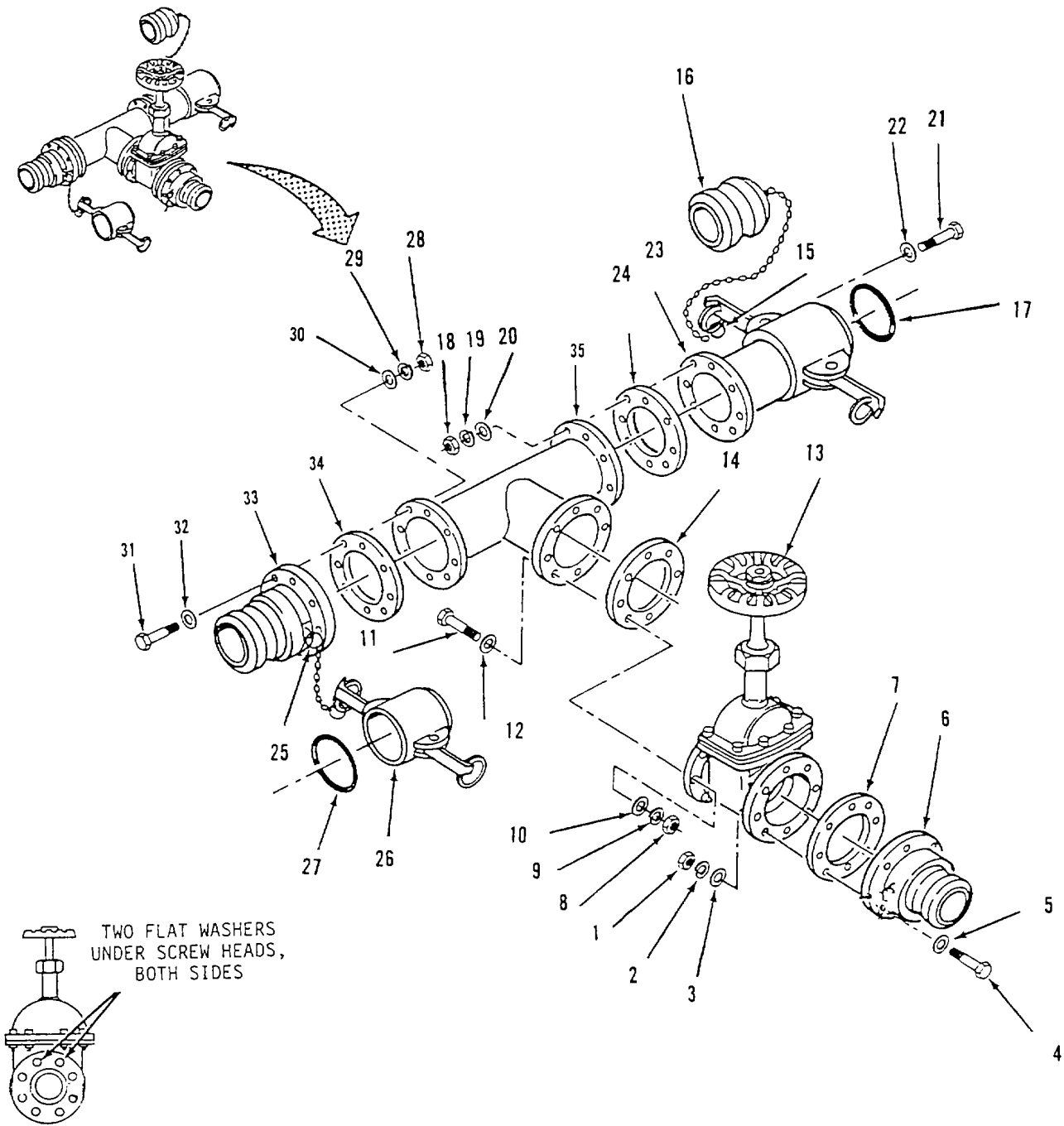

Figure 4-18.1. Tee and Gate Valve Assembly (9133-Y1) Disassembly.

4-25.1. TEE AND GATE VALVE ASSEMBLY (9133-Y1) REPAIR - cont.b. Cleaning.

- (1) Wash all components with clean water and detergent.
- (2) Rinse components in clean water and dry with wiping rag.

c. Inspection.

- (1) Inspect male couplings (6 and 33) for cracks.
- (2) Inspect female coupling (23) for cracks and damaged lock arms.
- (3) Inspect tee (35) for cracks or corrosion.

d. Repair.

- (1) Refer to para. 4-31a (9) to repair gate valve.
- (2) Replace defective components. Do not reuse sealing components.

e. Assembly. Refer to figure 4-18.2.

- (1) Position gasket (34) and male coupling (33) on tee (35).
- (2) Install eight flat washers (32), screws (31), flat washers (30), lockwashers (29) and nuts (28).

NOTE

Ensure gasket is fully seated in groove of cap.

- (3) Install gasket (27) in cap (26). Connect cap to male coupling (33) with ring (25).
- (4) Position gasket (24) and female coupling (23) on tee (35).
- (5) Install eight flat washers (22), screws (21), flat washers (20), lockwashers (19) and nuts (18).

NOTE

Ensure gasket is fully seated in groove of coupling.

- (6) Install gasket (17) in female coupling (23).

4-25.1. TEE AND GATE VALVE ASSEMBLY (9133-Y1) REPAIR - cont.

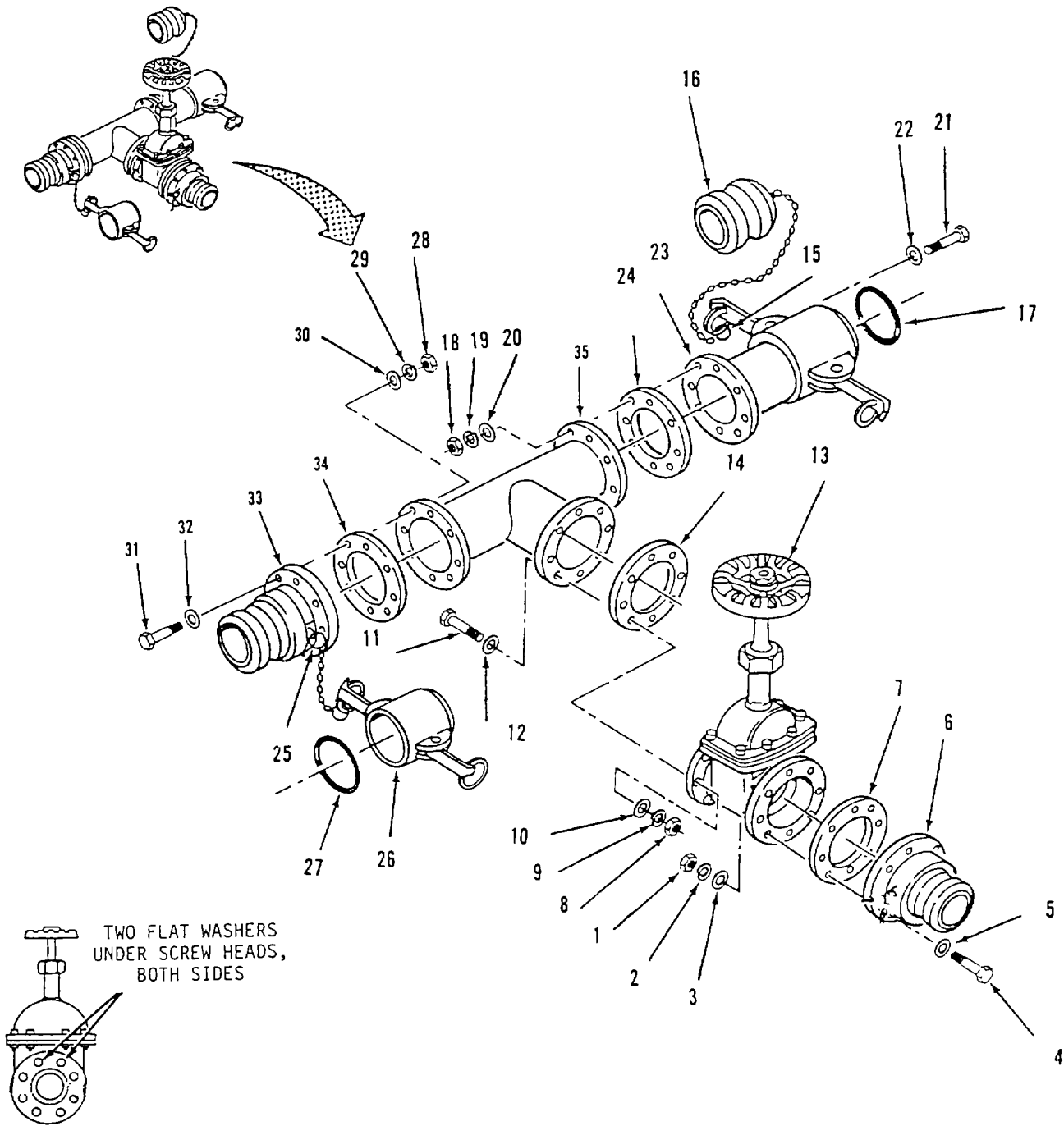

Figure 4-18.2. Tee and Gate Valve Assembly (9133-Y1) Assembly.

4-25.1. TEE AND GATE VALVE ASSEMBLY (9133-Y1) REPAIR - cont.

- (7) Connect plug (16) to female coupling (23) with ring (15).
- (8) Position gasket (14) and gate valve (13) on tee (35).

NOTE

Use two additional flat washers (12 and 5) at the top two screw holes (four per gate valve) to prevent the screws from coming in contact with the gate valve body and to assure proper torque.

- (9) Install ten flat washers (12) and eight screws (11), flat washers (10), lockwashers (9) and nuts (8).
- (10) Position gasket (7) and male coupling (6) on gate valve (13).
- (11) Install ten flat washers (5) and eight screws (4), flat washers (3), lockwashers (2) and nuts (1).
- (12) Install tee and gate valve assembly in water system (para. 3-4a).
- (13) Startup water system (para. 2-12c) and check tee and gate valve assembly for leaks.

4-26. 350 GPM PUMP CONNECTION KIT MAINTENANCE.

The 350 gpm pump connection kit consists of the components listed below. Refer to the following paragraphs for applicable maintenance procedures.

Procedure	Para.
Tee Assembly (9112-Y1) Repair.....	4-27
Tee Assembly (9112-Y2) Repair.....	4-28
Tee Assembly (9112-Y3) Repair.....	4-29
Tee Assembly (9112-Y4) Repair.....	4-30
Discharge Hose Repair.....	4-14
Gate Valve Assembly (4-inch) Repair.....	4-31
Water Meter Assembly Repair.....	4-32
Water Meter Assembly Repair (Model 800KWSDS).....	4-32.1

4-27. TEE ASSEMBLY (9112-Y1) REPAIR.

This task consists of:	a. Disassembly	b. Cleaning	c. Inspection
	d. Repair	e. Assembly	

4-27. TEE ASSEMBLY (9112-Y1) REPAIR - cont.
--

INITIAL SET-UP:	
Tools: General Mechanics Tool Kit (Item 1, App. B)	Wiping Rag (Item 2, App E) Tape, Anti-seize (Item 3, App E)
Equipment Condition: Tee assembly removed (para 3-4a)	Gasket (2) (Item 4, App I) Gasket (3) (Item 10, App I)
Material/Parts: Lockwasher (24) (Item 11, App I) Detergent, General Purpose (Item 1, App E)	Lockwasher (24) (Item 11, App I)

NOTE

Ensure that all parts identified as mandatory replacement parts are discarded and replaced with new components.

a. Disassembly. Refer to figure 4-19.

(1) Remove gasket (1) from female coupling (7).

(2) Remove eight nuts (2), lockwashers (3), flat washers (4) screws (5) and flat washers (6).

(3) Separate female coupling (7) and gasket (8) from tee (24).

(4) Remove eight nuts (9), lockwashers (10), flat washers (11), screws (12) and flat washers (13).

(5) Separate male coupling (14) and gasket (15) from tee (24).

(6) Remove gasket (16) from female coupling (22).

(7) Remove eight nuts (17), lockwashers (18), flat washers (19) screws (20) and flat washers (21).

4-27. TEE ASSEMBLY (9112-Y1) REPAIR - cont.

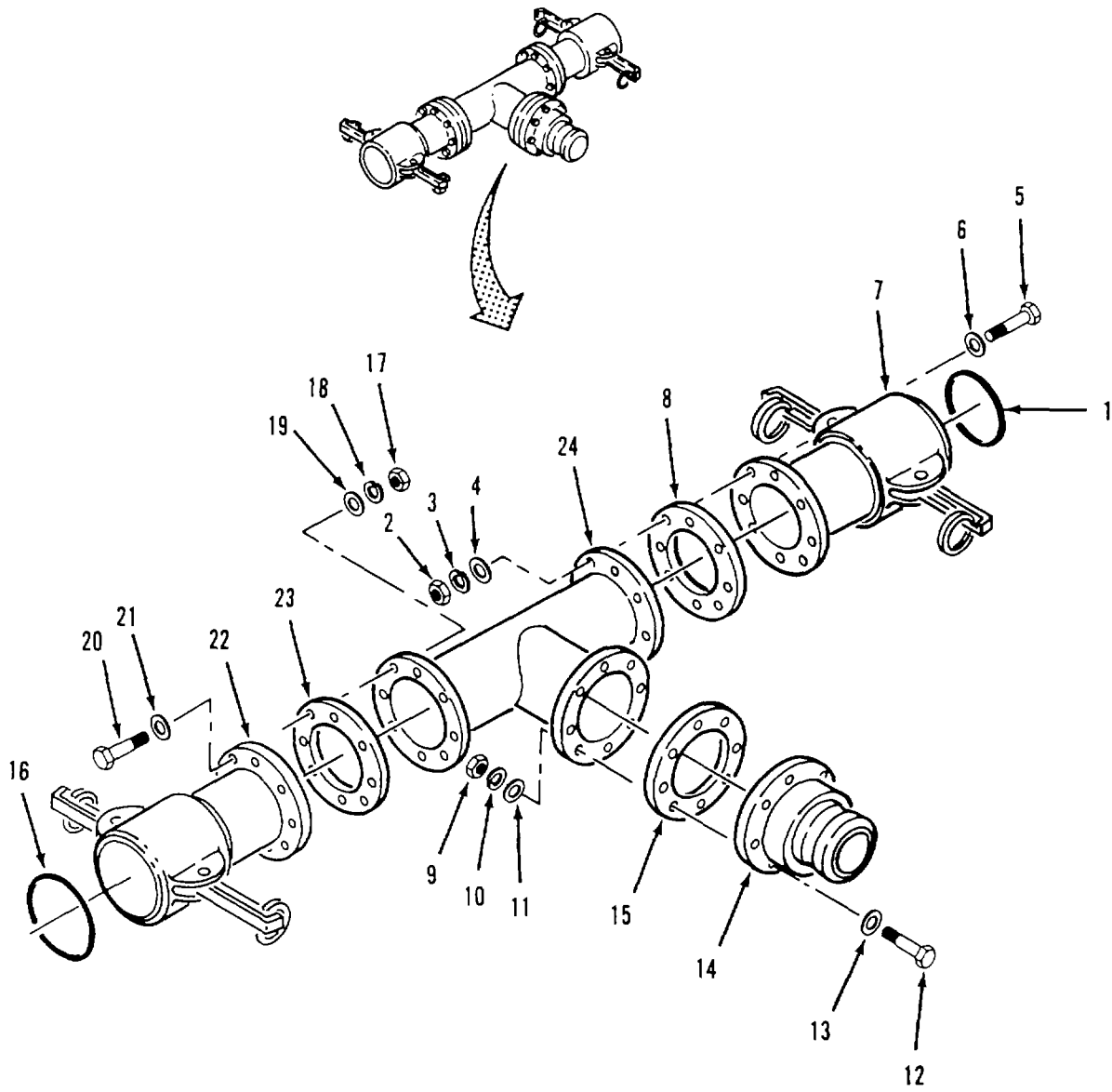

Figure 4-19. Tee Assembly (9112-Y1) Disassembly

4-27. TEE ASSEMBLY (9112-Y1) REPAIR - cont.
--

b. Cleaning.

- (1) Wash all components with clean water and detergent.
- (2) Rinse components in clean water and dry with wiping rag.

c. Inspection.

- (1) Inspect male coupling (14) for cracks.
- (2) Inspect female couplings (7 and 22) for cracks and damaged lock arms.
- (3) Inspect tee (24) for cracks and corrosion,

d. Repair. Replace defective components. Do not reuse sealing components.e. Assembly. Refer to figure 4-20.

- (1) Position gasket (23) and female coupling (22) on tee (24).
- (2) Install eight flat washers (21), screws (20), flat washers (19) lockwashers (18) and nuts (17)

NOTE

Ensure gasket is fully seated in groove of coupling.

- (3) Install gasket (16) in female coupling (22).
- (4) Position gasket (15) and male coupling (14) on tee (24).
- (5) Install eight flat washers (13), screws (12), flat washers (11), lockwashers (10) and nuts (9).
- (6) Position gasket (8) and female coupling (7) on tee (24).
- (7) Install eight flat washers (6), screws (5), flat washers (4) lockwashers (3) and nuts (2).

NOTE

Ensure gasket is fully seated in groove of coupling.

- (8) Install gasket (1) in female coupling (7).
- (9) Install tee assembly in water system (para 3-4a).
- (10) Startup water system (para 2-12c) and check tee assembly for leaks.

4-27. TEE ASSEMBLY (9112-Y1) REPAIR - cont.

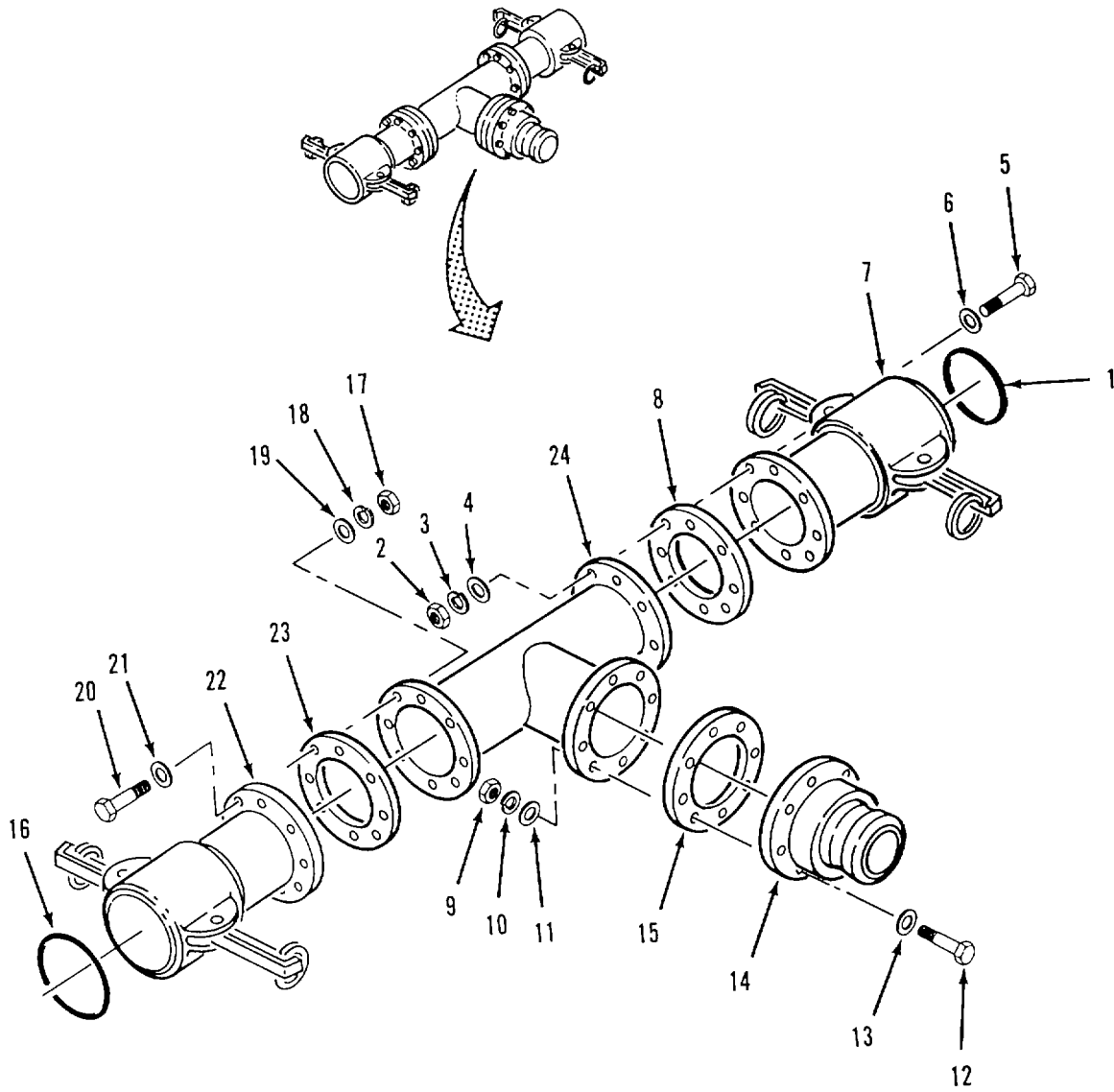

Figure 4-20. Tee Assembly (9112-Y1) Assembly

4-28. TEE ASSEMBLY (9112-Y2) REPAIR.

This task consists of:

a. Disassembly	b. Cleaning	c. Inspection
d. Repair	e. Assembly	

INITIAL SET-UP:**Tools:**

General Mechanics Tool Kit (Item 1, App. B)

Wiping Rag (Item 2, App E)

Tape, Anti-seize (Item 3, Appendix E)

Equipment Condition:

Tee assembly removed (para 3-4a)

Gasket (2) (Item 4, App I)

Gasket (3) (Item 10, App I)

Material/Parts:

Detergent, General Purpose (Item 1, App E)

Lockwasher (24) (Item 11, App I)

NOTE

Ensure that all parts identified as mandatory replacement parts are discarded and replaced with new components.

a. Disassembly. Refer to figure 4-21.

- (1) Remove gasket (1) from female coupling (7).
- (2) Remove eight nuts (2), lockwashers (3), flat washers (4) and screws (5) and flat washers (6).
- (3) Separate female coupling (7) and gasket (8) from tee (26).
- (4) Disconnect ring (9) from male coupling (17) and remove cap (11).
- (5) Remove gasket (10) from cap (11).
- (6) Remove eight nuts (12), lockwashers (13), flat washers (14), screws (15) and flat washers (16).
- (7) Separate male coupling (17) and gasket (18) from tee (26).
- (8) Remove eight nuts (19), lockwashers (20), flat washers (21), screws (22) and flat washers (23).
- (9) Separate male coupling (24) and gasket (25) from tee (26).

b. Cleaning.

- (1) Wash all components with clean water and detergent.
- (2) Rinse components in clean water and dry with wiping rag.

c. Inspection.

- (1) Inspect male couplings (17 and 24) for cracks.

4-28. TEE ASSEMBLY (9112-Y2) REPAIR - cont.

- (2) Inspect female coupling (7) for cracks and damaged lock arms.
- (3) Inspect tee (26) for cracks and corrosion.

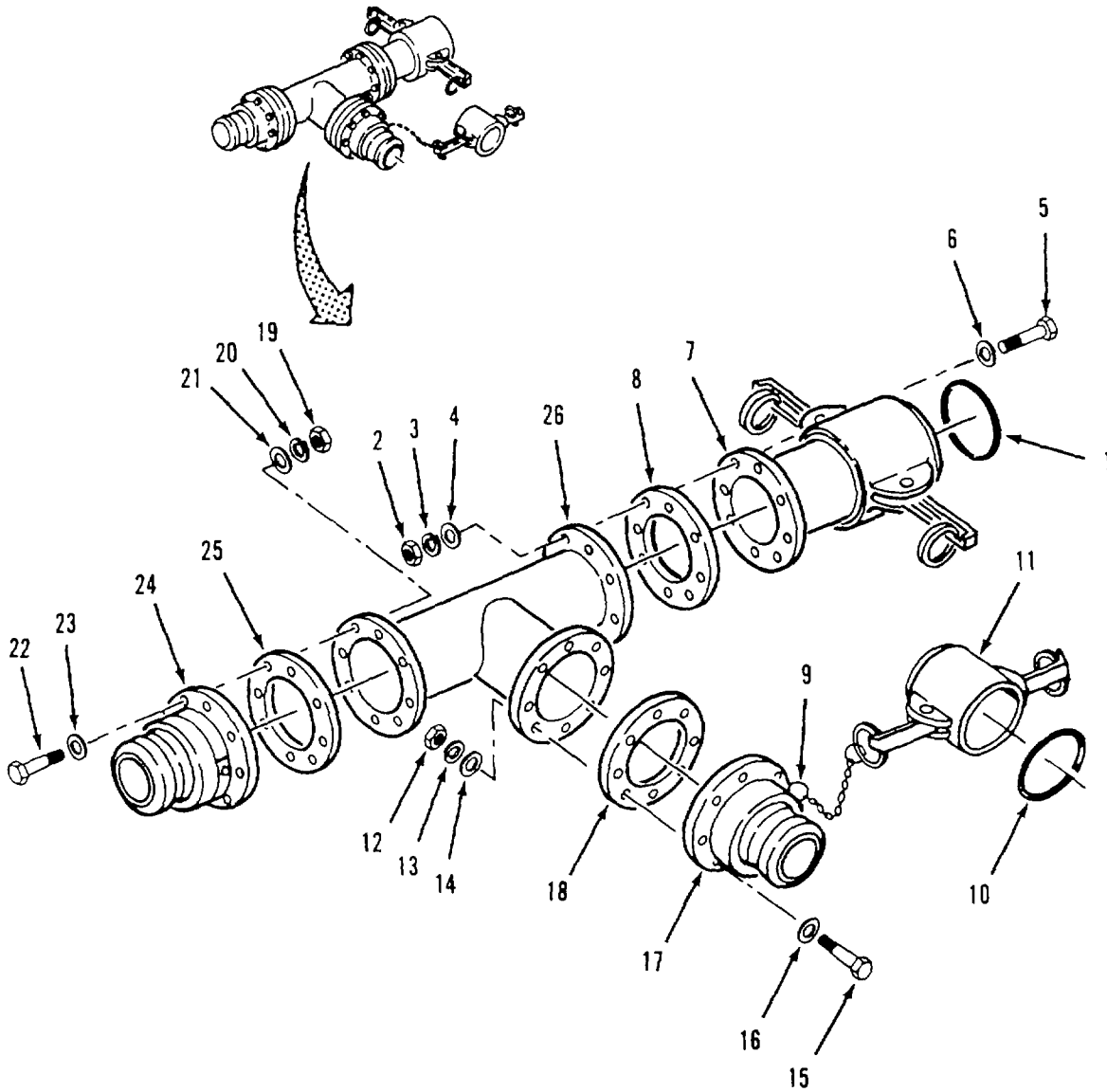

Figure 4-21. Tee Assembly (9112-Y2) Disassembly.

4-28. TEE ASSEMBLY (9112-Y2) REPAIR - cont.

- d. Repair. Replace defective components. Do not reuse sealing components.
- e. Assembly. Refer to figure 4-22.
- (1) Position gasket (25) and male coupling (24) on tee (26).
 - (2) Install eight flat washers (23), screws (22), flat washers (21), lockwashers (20) and nuts (19).
 - (3) Position gasket (18) and male coupling (17) on tee (26).
 - (4) Install eight flat washers (16), screws (15), flat washers (14), lockwashers (13) and nuts (12).
 - (5) Connect ring (9) and attached cap (11) to male coupling (17).

NOTE

Ensure gasket is fully seated in groove of cap.

- (6) Install gasket (10) in cap (11).
- (7) Position gasket (8) and female coupling (7) on tee (26).
- (8) Install eight flat washers (6), screws (5), flat washers (4) lockwashers (3) and nuts (2).

NOTE

Ensure gasket is fully seated in groove of coupling.

- (9) Install gasket (1) in female coupling (7).
- (10) Install tee assembly in water system (para 3-4a).
- (11) Startup water system (para 2-12c) and check tee assembly for leaks.

4-28. TEE ASSEMBLY (9112-Y2) REPAIR - cont.

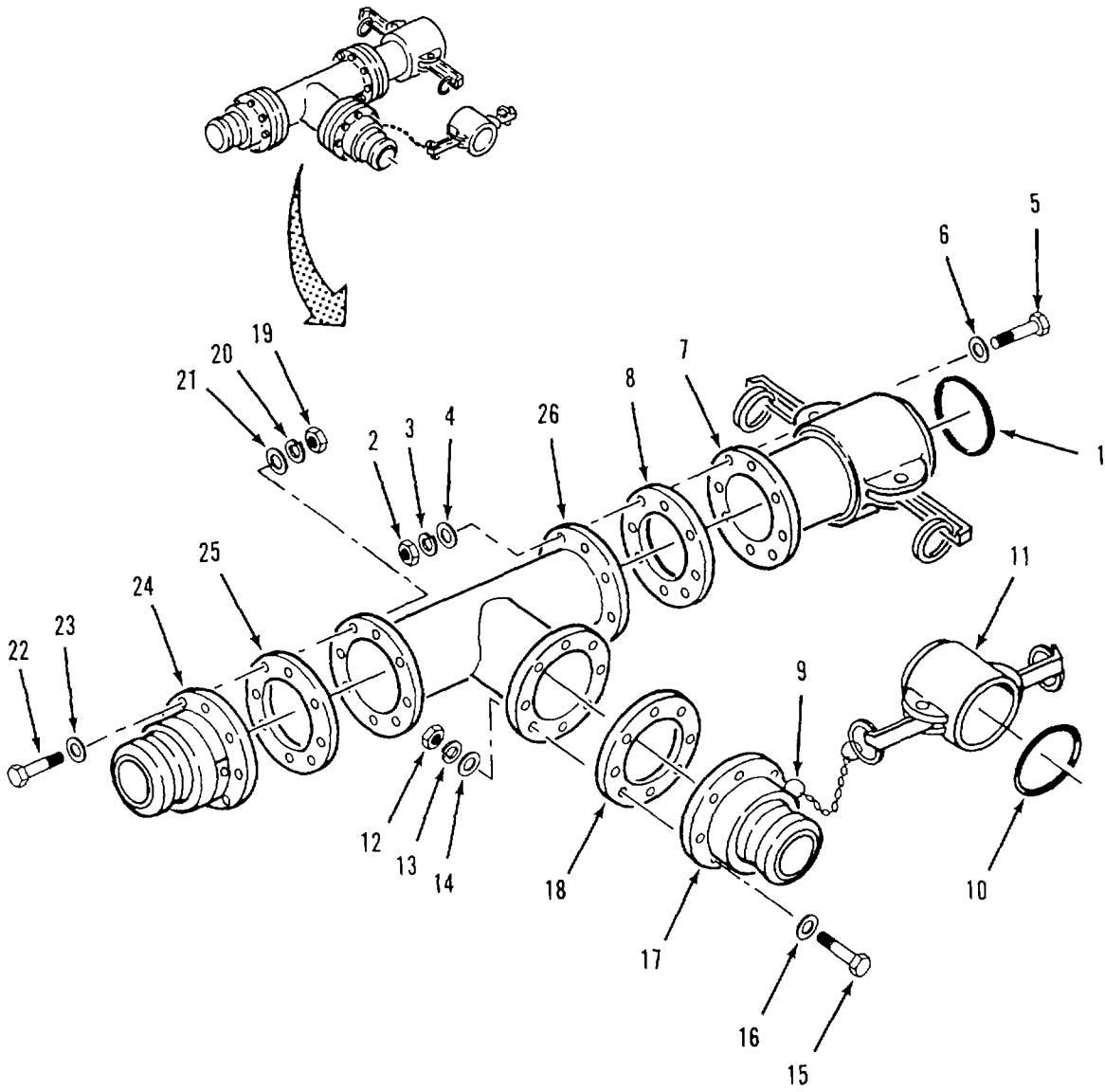

Figure 4-22. Tee Assembly (9112-Y2) Assembly

4-29. TEE ASSEMBLY (9112-Y3) REPAIR.

This task consists of:

a. Disassembly	b. Cleaning	c. Inspection
d. Repair	e. Assembly	

INITIAL SET-UP:**Tools:**

General Mechanics Tool Kit (Item 1, App. B)

Wiping Rag (Item 2, App E)

Tape, Anti-seize (Item 3, Appendix E)

Equipment Condition:

Tee assembly removed (para 3-4a)

Gasket (2) (Item 4, App I)

Gasket (3) (Item 10, App I)

Material/Parts:

Detergent, General Purpose (Item 1, App E)

Lockwasher (24) (Item 11, App I)

NOTE

Ensure that all parts identified as mandatory replacement parts are discarded and replaced with new components.

- a. Disassembly. Refer to figure 4-23.
- (1) Remove gasket (1) from female coupling (7).
 - (2) Remove eight nuts (2), lockwashers (3), flat washers (4) and screws (5) and flat washers (6).
 - (3) Separate female coupling (7) and gasket (8) from tee (26).
 - (4) Disconnect ring (9) from female coupling (17) and remove plug (10).
 - (5) Remove gasket (11) from female coupling (17).
 - (6) Remove eight nuts (12), lockwashers (13), flat washers (14), screws (15) and flat washers (16).
 - (7) Separate female coupling (17) and gasket (18) from tee (26).
 - (8) Remove eight nuts (19), lockwashers (20), flat washers (21), screws (22) and flat washers (23).
 - (9) Separate male coupling (24) and gasket (25) from tee (26).
- b. Cleaning.
- (1) Wash all components with clean water and detergent.
 - (2) Rinse components in clean water and dry with wiping rag.
- c. Inspection.
- (1) Inspect male coupling (24) for cracks.

4-29. TEE ASSEMBLY (9112-Y3) REPAIR - cont.

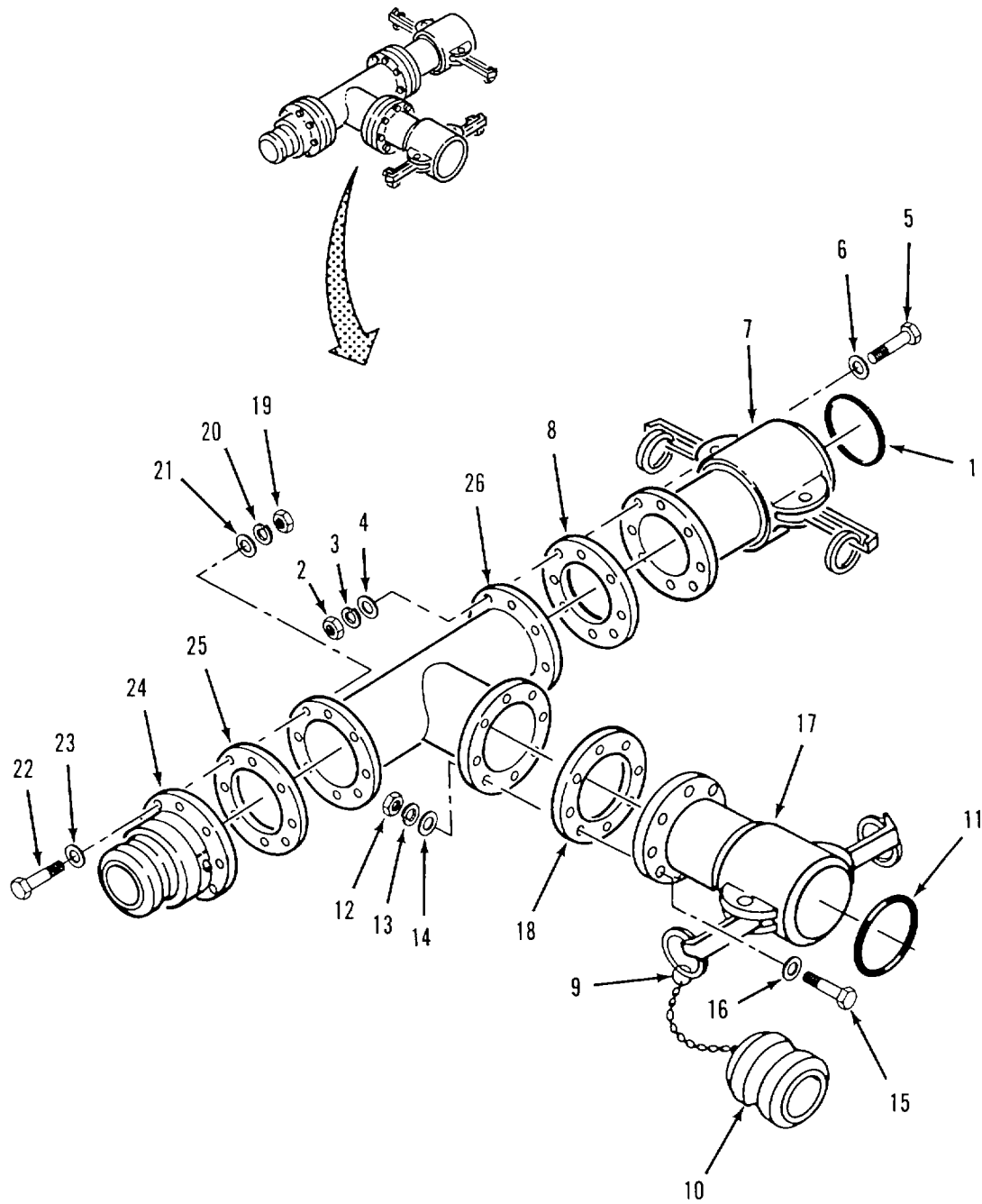

Figure 4-23. Tee Assembly (9112-Y3) Disassembly

4-29. TEE ASSEMBLY (9112-Y3) REPAIR - cont.

- d. Repair. Replace defective components. Do not reuse scaling components.
- e. Assembly. Refer to figure 4-24.
 - (1) Position gasket (25) and male coupling (24) on tee (26).
 - (2) Install eight flat washers (23), screws (22), flat washers (21), lockwashers (20) and nuts (19).
 - (3) Position gasket (18) and female coupling (17) on tee (26).
 - (4) Install eight flat washers (16), screws (15), flat washers (14), lockwashers (13) and nuts (12).
 - (5) Connect ring (9) and attached plug (10) to female coupling (17).

NOTE

Ensure gasket is fully seated in groove of coupling.

- (6) Install gasket (11) in female coupling (17).
- (7) Position gasket (8) and female coupling (7) on tee (26).
- (8) Install eight flat washers (6), screws (5), flat washers (4) lockwashers (3) and nuts (2).

NOTE

Ensure gasket is fully seated in groove of coupling.

- (9) Install gasket (1) in female coupling (7).
- (10) Install tee assembly in water system (para 3-4a).
- (11) Startup water system (para 2-12c) and check tee assembly for leaks.

4-29. TEE ASSEMBLY (9112-Y3) REPAIR - cont.

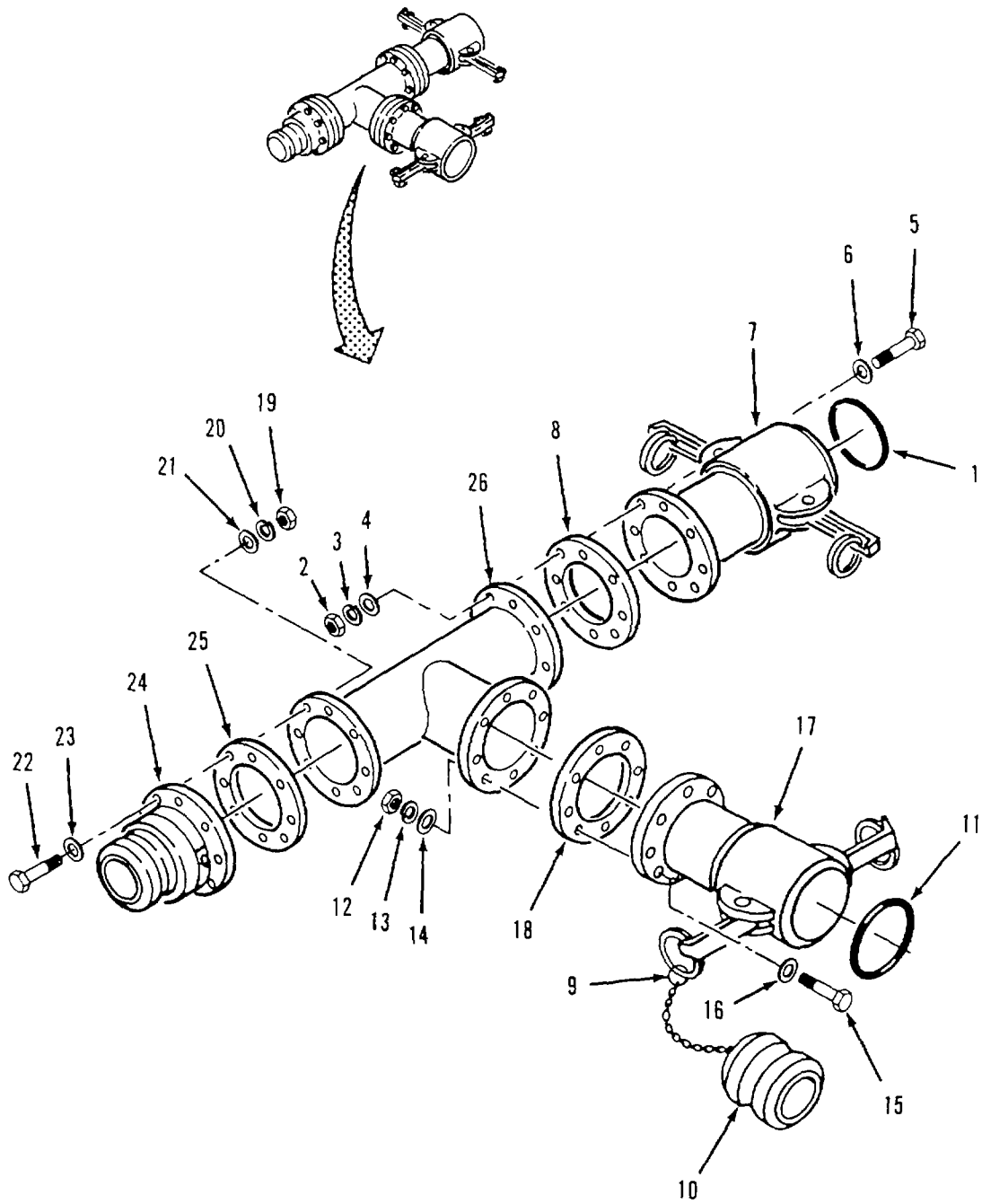

Figure 4-24. Tee Assembly (9112-Y3) Assembly

4-30. TEE ASSEMBLY (9112-Y4) REPAIR.

This task consists of:

a. Disassembly	b. Cleaning	c. Inspection
d. Repair	e. Assembly	

INITIAL SET-UP:	
Tools: General Mechanics Tool Kit (Item 1, App B)	Wiping Rag (Item 2, App E) Tape, Anti-seize (Item 3, Appendix E)
Equipment Condition: Tee assembly removed (para 3-4a)	Gasket (Item 4, App I) Gasket (3) (Item 10, App I)
Material/Parts: Detergent, General Purpose (Item 1, App E)	Lockwasher (24) (Item 11, App I)

NOTE

Ensure that all parts identified as mandatory replacement parts are discarded and replaced with new components.

- a. Disassembly. Refer to figure 4-25.
- (1) Remove eight nuts (1), lock-washers (2), flat washers (3) and screws (4) and flat washers (5).
 - (3) Separate male coupling (6) and gasket (7) from tee (23).
 - (3) Remove gasket (8) from female coupling (14).
 - (6) Remove eight nuts (9), lockwashers (10), flat washers (11), screws (12) and flat washers (13)
 - (7) Separate female coupling (14) and gasket (15) from tee (23).
 - (8) Remove eight nuts (16), lockwashers (17), flat washers (18), screws (19) and flat washers (20).
 - (9) Separate male coupling (21) and gasket (22) from tee (23).
- b. Cleaning.
- (1) Wash all components with clean water and detergent.
 - (2) Rinse components in clean water and dry with wiping rag.
- c. Inspection.
- (1) Inspect male couplings (6 and 21) for cracks.
 - (2) Inspect female coupling (14) for cracks and damaged lock arms.
 - (3) Inspect tee (23) for cracks and corrosion.

4-30. TEE ASSEMBLY (9112-Y4) REPAIR - cont.

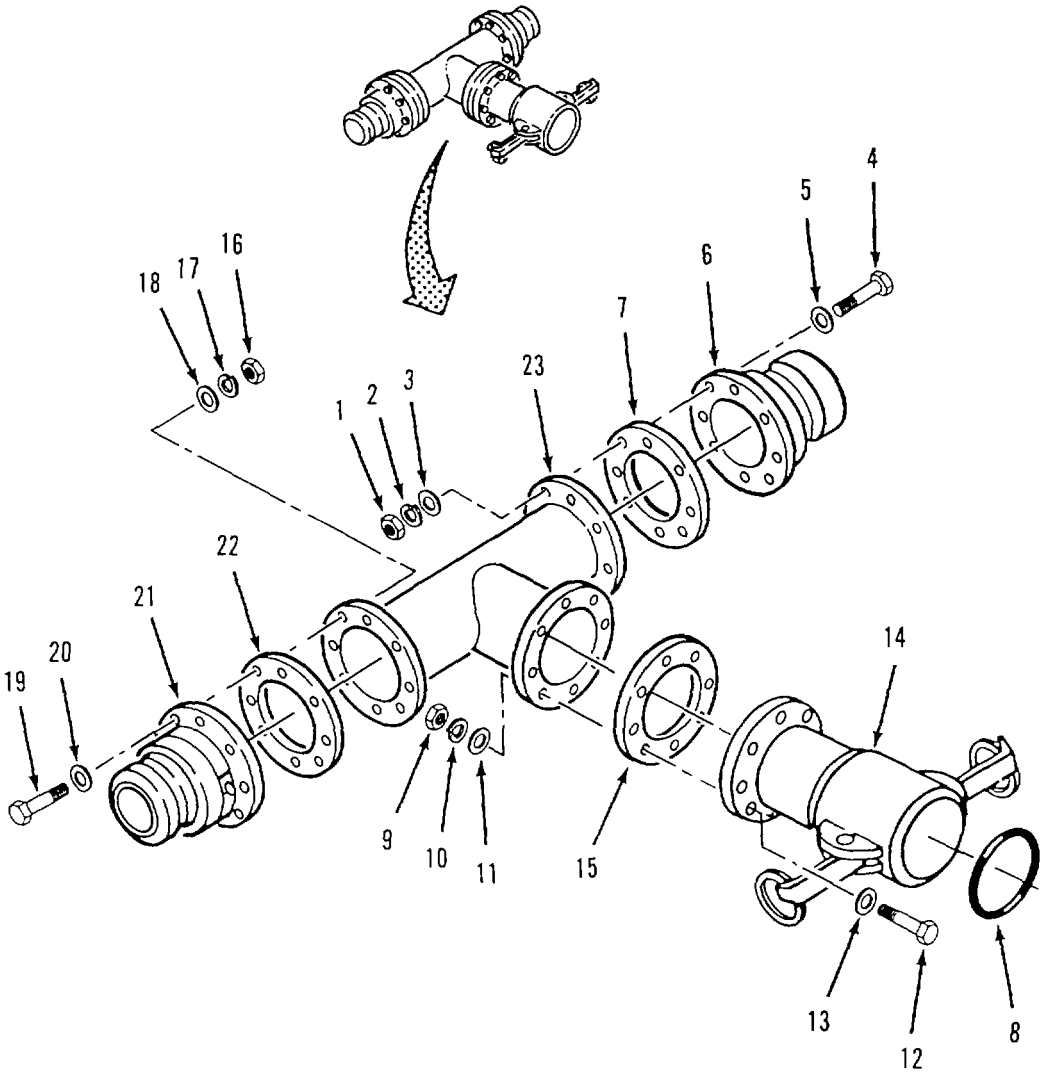

Figure 4-25. Tee Assembly (9112-Y4) Disassembly

4-30. TEE ASSEMBLY (9112-Y4) REPAIR - cont.

- d. Repair. Replace defective components. Do not reuse sealing components.
- e. Assembly. Refer to figure 4-26.
 - (1) Position gasket (22) and male coupling (21) on tee (23).
 - (2) Install eight flat washers (20), screws (19), flat washers (18), lockwashers (17) and nuts (16).
 - (3) Position gasket (15) and female coupling (14) on tee (23).
 - (4) Install eight flat washers (13), screws (12), flat washers (11), lockwashers (10) and nuts (9).

NOTE

Ensure gasket is fully seated in groove of coupling.

- (5) Install gasket (8) in female coupling (14).
- (6) Position gasket (7) and male coupling (6) on tee (23).
- (7) Install eight flat washers (5), screws (4), flat washers (3) lockwashers (2) and nuts (1).
- (8) Install tee assembly in water system (para 3-4a).
- (9) Startup water system (para 2-12c) and check tee assembly for leaks.

4-30. TEE ASSEMBLY (9112-Y4) REPAIR - cont.

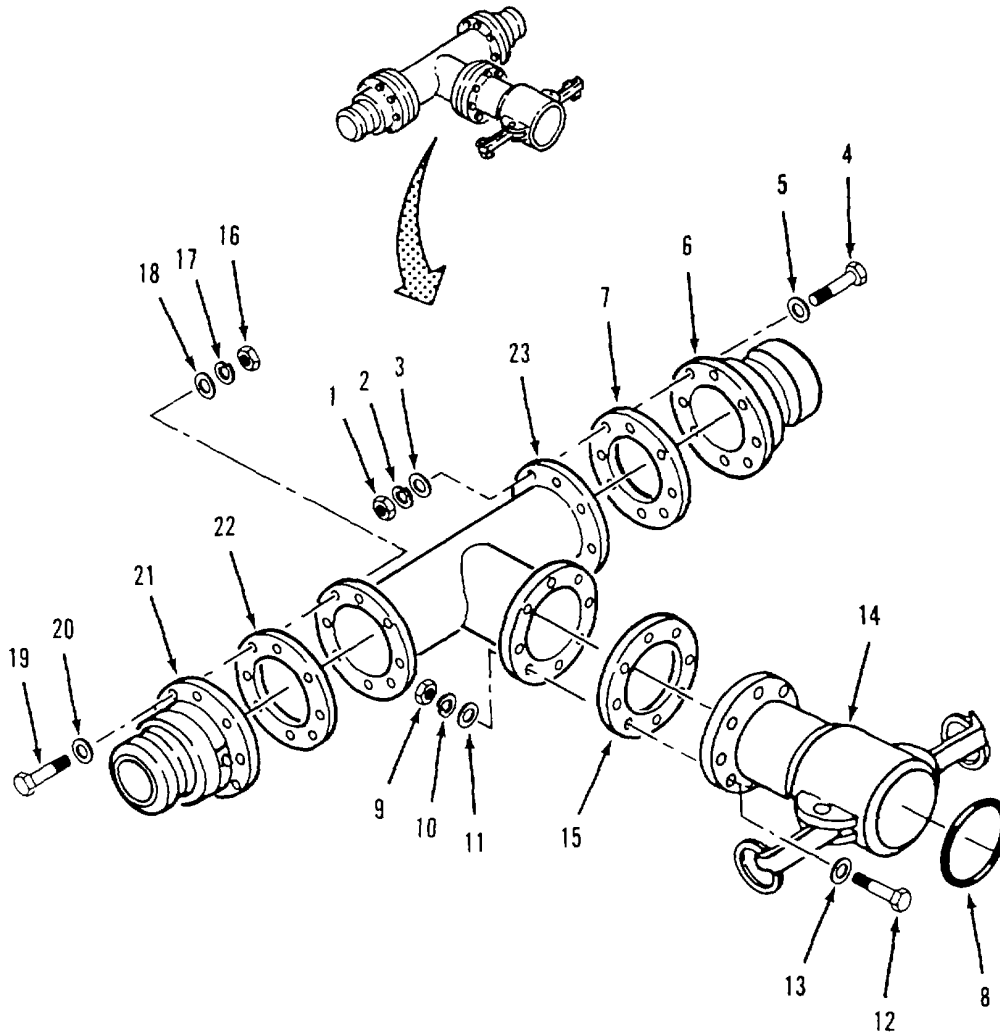

Figure 4-26. Tee Assembly (9112-Y4) Assembly

4-31. GATE VALVE ASSEMBLY (4-INCH) REPAIR.

This task consists of:	a. Disassembly	b. Cleaning	c. Inspection
	d. Repair	e. Assembly	

INITIAL SET-UP:**Tools:**

General Mechanics Tool Kit (Item 1, App B)

Tape, Anti-seize (Item 3, Appendix E)

Gasket (2) (Item 4, App I)

Equipment Condition:

4-inch gate valve assembly removed (para 3-4a)

Gasket (3) (Item 10, App I)

Lockwasher (24) (Item 11, App I)

Material/Parts:

Detergent, General Purpose (Item 1, App E)

Packing Ring (Item 28, App I)

Wiping Rag (Item 2, App E)

Flange Gasket (Item 29, App I)

Lockwasher (8) (Item 30, App I)

NOTE

Ensure that all parts identified as mandatory replacement parts are discarded and replaced with new components.

a. Disassembly.

Remove gate valve. Refer to figure 4-27.

- (1) Disconnect ring (1) from male coupling (9) and remove cap (3).
- (2) Remove gasket (2) from cap (3).
- (3) Remove eight nuts (4), lockwashers (5), flat washers (6), screws (7) and ten flat washers (8).
- (4) Separate male coupling (9) and gasket (10) from gate valve (21).
- (5) Disconnect ring (11) from female coupling (19) and remove plug (12).
- (6) Remove gasket (13) from female coupling (19).
- (7) Remove eight nuts (14), lockwashers (15), flat washers (16), screws (17) and ten flat washers (18).
- (8) Separate female coupling (19) and gasket (20) from gate valve (21).

Disassemble gate valve. Refer to figure 4-28.

- (9) Remove nut (1) and handwheel (2) from stem (12).
- (10) Remove packing nut (3), gland spring (4), packing gland (5) and packing ring (6) from top of bonnet (10)
- (11) Remove eight nuts (7), lockwashers (8), and screws (9) and ten flat washers (18) from valve body (17) and bonnet (10).

4-31. GATE VALVE ASSEMBLY (4-INCH) REPAIR - cont.

NOTE

If needed, tap bonnet with mallet to loosen scaling surfaces.

(12) Remove bonnet (10), gasket (11), and attached parts from valve body (17).

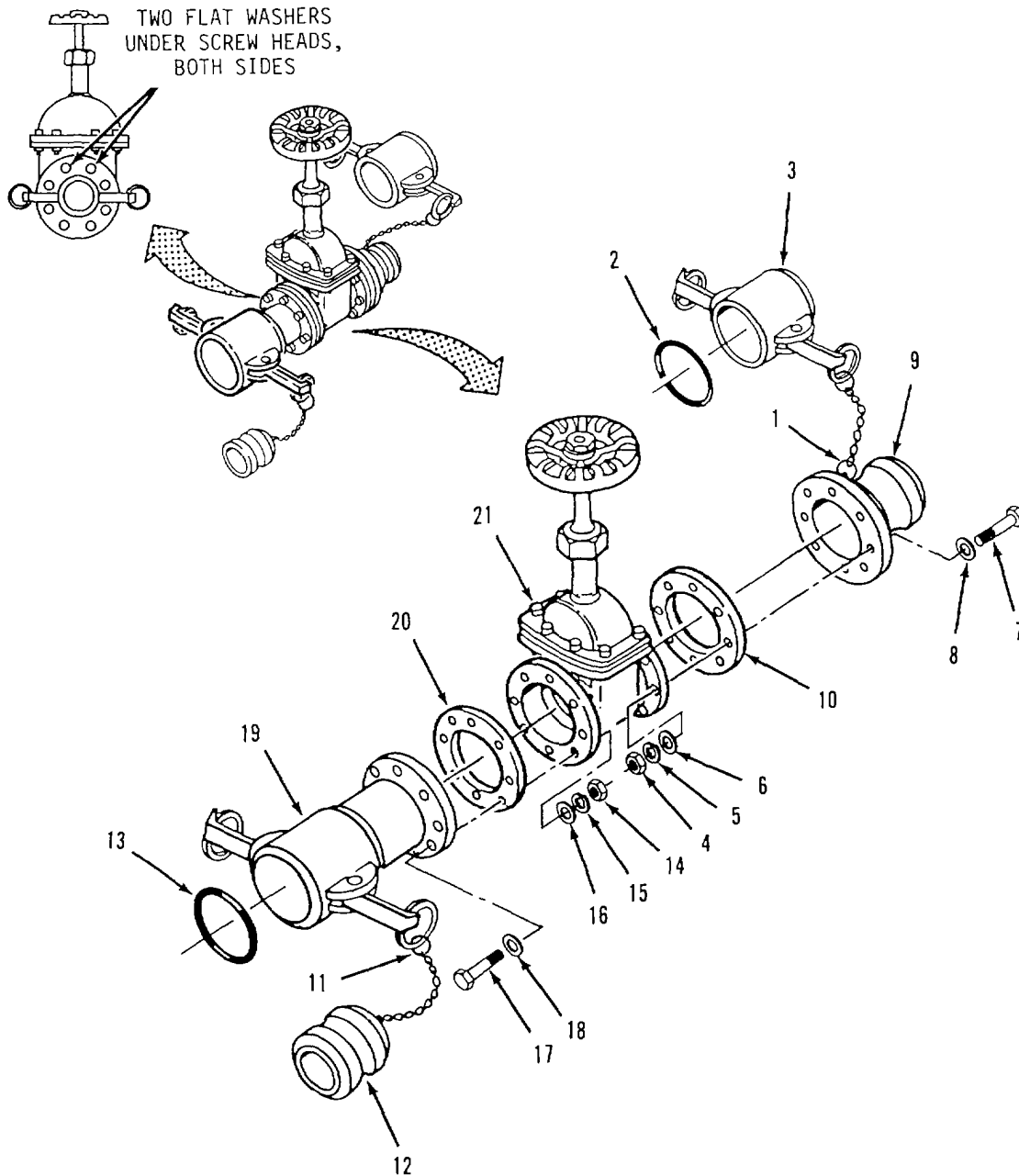

Figure 4-27. Gate Valve Assembly (4-Inch) Disassembly.

4-31. GATE VALVE ASSEMBLY (4-INCH) REPAIR - cont.

- (13) Remove two screws (13) and separate discs (14 and 15) from disc riser (16).
- (14) Remove disc riser (16) from stem (12).
- (15) Unscrew stem (12) from bottom of bonnet (10).

b. Cleaning.

- (1) Wash all components with clean water and detergent.
- (2) Rinse components in clean water and dry with wiping rag.

c. Inspection.

- (1) Inspect bonnet (10) and valve body (17) for cracks, scored mating surfaces, stripped threads and corrosion.
- (2) Inspect for bent stem (12) and galled or stripped threads.
- (3) Inspect sealing surfaces of discs (14 and 15) and valve body (17) for deep scratches and cracks.
- (4) Inspect male coupling (9, figure 4-26) for cracks and corrosion.
- (5) Inspect female coupling (19) and cap (3) for cracks and broken locking arms.

d. Repair. Replace damaged or defective parts. Replace all sealing components.**e. Assembly.**

Assemble gate valve. Refer to figure 4-28.

- (1) Screw stem (12) all the way into bottom of bonnet (10), then back out stem three full turns. Do not allow stem to move from this position.
- (2) While holding stem (12) in place, screw disc riser (16) onto stem until bottom of riser is flush with end of stem.
- (3) Position discs (14 and 15) on riser (16) and install two screws (13).
- (4) While preventing stem (12) from turning in bonnet (10), turn discs (14 and 15) and riser (16) counterclockwise onto stem until top of discs contact bottom of bonnet.
- (5) Position gasket (11) on valve body (17).
- (6) While holding stem (12) in position, lower bonnet (10) and discs (14 and 15) into valve body (17). Do not rotate discs more than 1/4 turn to align discs with body.

4-31. GATE VALVE ASSEMBLY (4-INCH) REPAIR - cont.

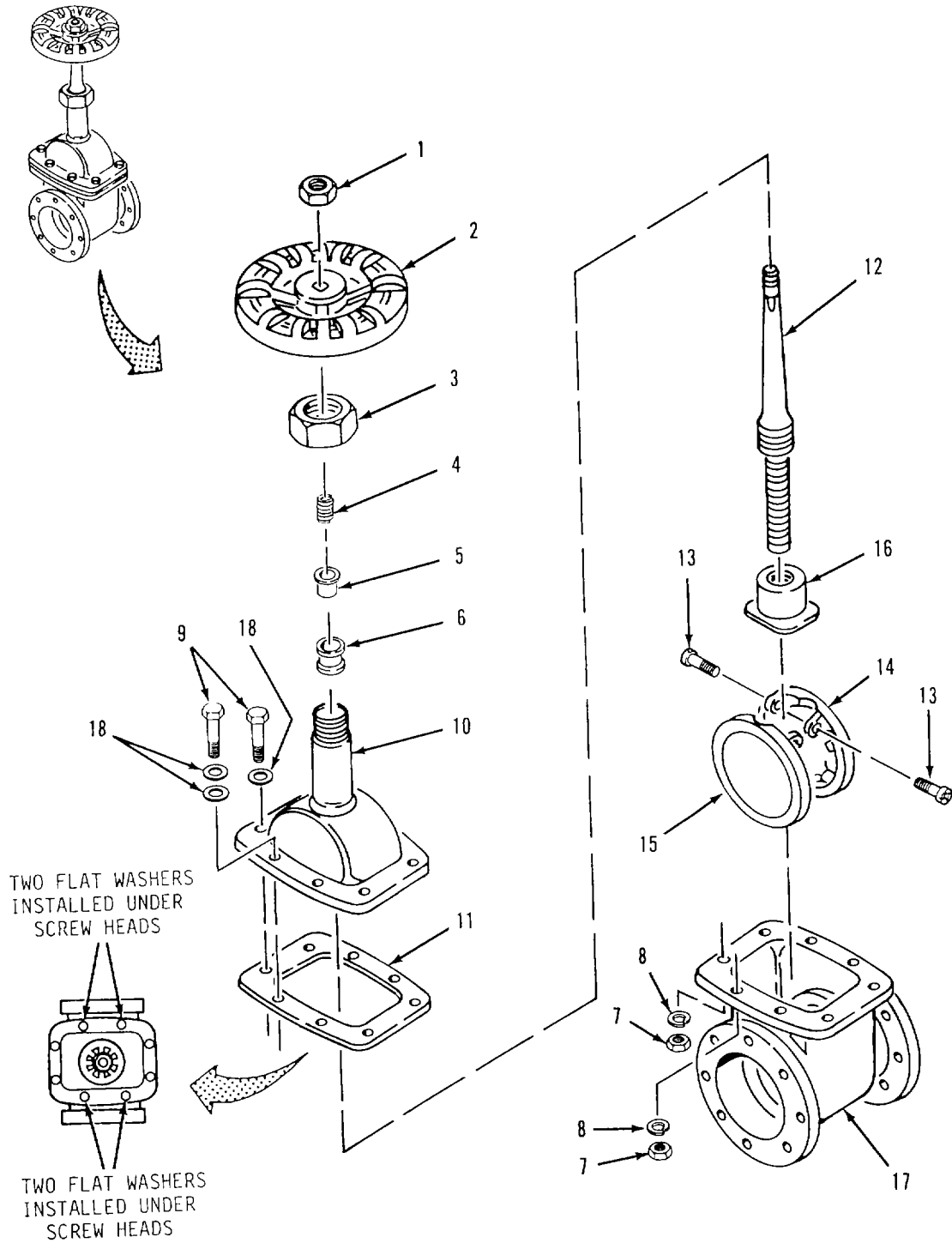

Figure 4-28. Gate Valve Assembly (4-Inch) Repair.

4-31. GATE VALVE ASSEMBLY (4-INCH) REPAIR - cont.**NOTE**

Two flat washers must be installed under the screw heads in the positions shown.

- (7) Install twelve flat washers (18), eight screws (9), lockwashers (8) and nuts (7) in valve body (17) and bonnet (10). Make sure two flat washers are installed under screw heads (four places) as shown.
- (8) Slide packing ring (6) over stem (12) and down into bonnet (10).
- (9) Slide packing gland (5) and gland spring (4) over stem (12).
- (10) Slide packing nut (3) over stem (12) and tighten onto top of bonnet (10).
- (11) Position handwheel (2) on stem (10) and secure with nut (1).

Install gate valve. Refer to figure 4-27.

NOTE

Install female coupling with locking arms positioned as shown.

- (12) Position gasket (20) and female coupling (19) on gate valve (21).
- (13) Install ten flat washers (18), eight screws (17), flat washers (16), lockwashers (15) and nuts (14). Make sure two flat washers (18) are installed under screw heads in positions shown.

NOTE

Ensure gasket is fully seated in groove of coupling.

- (14) Install gasket (13) in female coupling (19).
- (15) Connect plug (12) to female coupling (19) with ring (11).
- (16) Position gasket (10) and male coupling (9) on gate valve (21).
- (17) Install ten flat washers (8), eight screws (7), flat washers (6), lockwashers (5) and nuts (4). Make sure two flat washers (18) are installed under screw heads in positions shown.

NOTE

Ensure gasket is fully seated in groove of cap.

- (18) Install gasket (2) in cap (3).
- (19) Connect cap (3) to male coupling (9) with ring (1).
- (20) Install gate valve assembly in water system (para 3-4a).
- (21) Startup water system (para 2-12c) and check gate valve assembly for leaks.

4-32. WATER METER ASSEMBLY REPAIR.

This task consists of: a. Disassembly b. Cleaning c. Inspection
 d. Repair e. Assembly

INITIAL SET-UP:**Tools:**

General Mechanics Tool Kit (Item 1, App B)
 Pipe Wrench (from accessory kit)
 Vice (Item 2, App B)

Equipment Condition:

Water valve assembly removed (para 3-4a)

Material/Parts:

Detergent, General Purpose (Item 1, App E)
 Wiping Rag (Item 2, App E)
 Tape, Anti-seize (Item 3, Appendix E)
 Gasket (2) (Item 4, App I)
 Lockwashers (16) (Item 1, App I)
 Gasket, Flange (2) (Item 10, App I)
 Packing (Item 39, App I)
 Self Locking Nut (16) (Item 40, App I)

NOTE

Ensure that all parts identified as mandatory replacement parts are discarded and replaced with new components

a. Disassembly. Refer to figure 4-29.

- (1) Disconnect ring (1) from male coupling (9) and remove cap (3).
- (2) Remove gasket (2) from cap (3)
- (3) Remove eight self locking nuts (4) and screws (5).
- (4) Separate male coupling (6) and gasket (7) from meter (1 5)
- (5) Disconnect ring (8) from female coupling (13) and remove plug (9)
- (6) Remove gasket (10) from female coupling (13).
- (7) Remove eight self locking nuts (11) and screws (12).
- (8) Separate female coupling (13) and gasket (14) from meter (15).
- (9) If required, remove female coupling end (16) and nipple (17) from adapter (18)
- (10) If required, remove male coupling end (19) and nipple (20) from adapter (21).
- (11) Remove ten bolts (22) and lift metering element (23) from body (25).
- (12) Remove packing (24) from body (25).

4-32. WATER METER ASSEMBLY REPAIR - cont.c. Cleaning.

- (1) Wash all components with clean water and detergent.
- (2) Rinse components in clean water and dry with wiping rag.

d. Inspection.

- (1) Inspect female coupling end (16), male coupling end (19) and adapters (18 and 21) for cracks, stripped threads, and corrosion.
- (2) Inspect body (25) for cracks and corrosion
- (3) Inspect metering element (23) for cracks, damage, and corrosion.

e. Repair. Replace damaged or defective parts Replace all scaling componentsf. Assembly. Refer to figure 4-29.**NOTE**

Ensure packing is fully seated in groove of body.

- (1) Position packing (24) in body (25)
- (2) Lower metering element (23) onto body (25). Make sure arrow on top of element is pointing in the same direction as the arrow on the body.
- (3) Install ten bolts (22) in metering element (23).

NOTE

Ensure that anti-seize tape is applied in the same direction as the treads.

- (4) If removed, apply anti-seize tape to male threads of nipple (20). Install male coupling end (19) and nipple (20) on adapter (21).
- (5) If removed, apply anti-seize tape to male threads of nipple (17). Install nipple and female coupling end (16) on adapter (18)
- (6) Position gasket (14) and female coupling (13) on meter (15).
- (7) Install eight screws (12) and self locking nuts (11).

NOTE

Ensure gasket is fully seated in groove of coupling.

- (8) Install gasket (10) in female coupling (13).
- (9) Connect plug (9) to female coupling (13) with ring (8).

4-32. WATER METER ASSEMBLY REPAIR - cont.

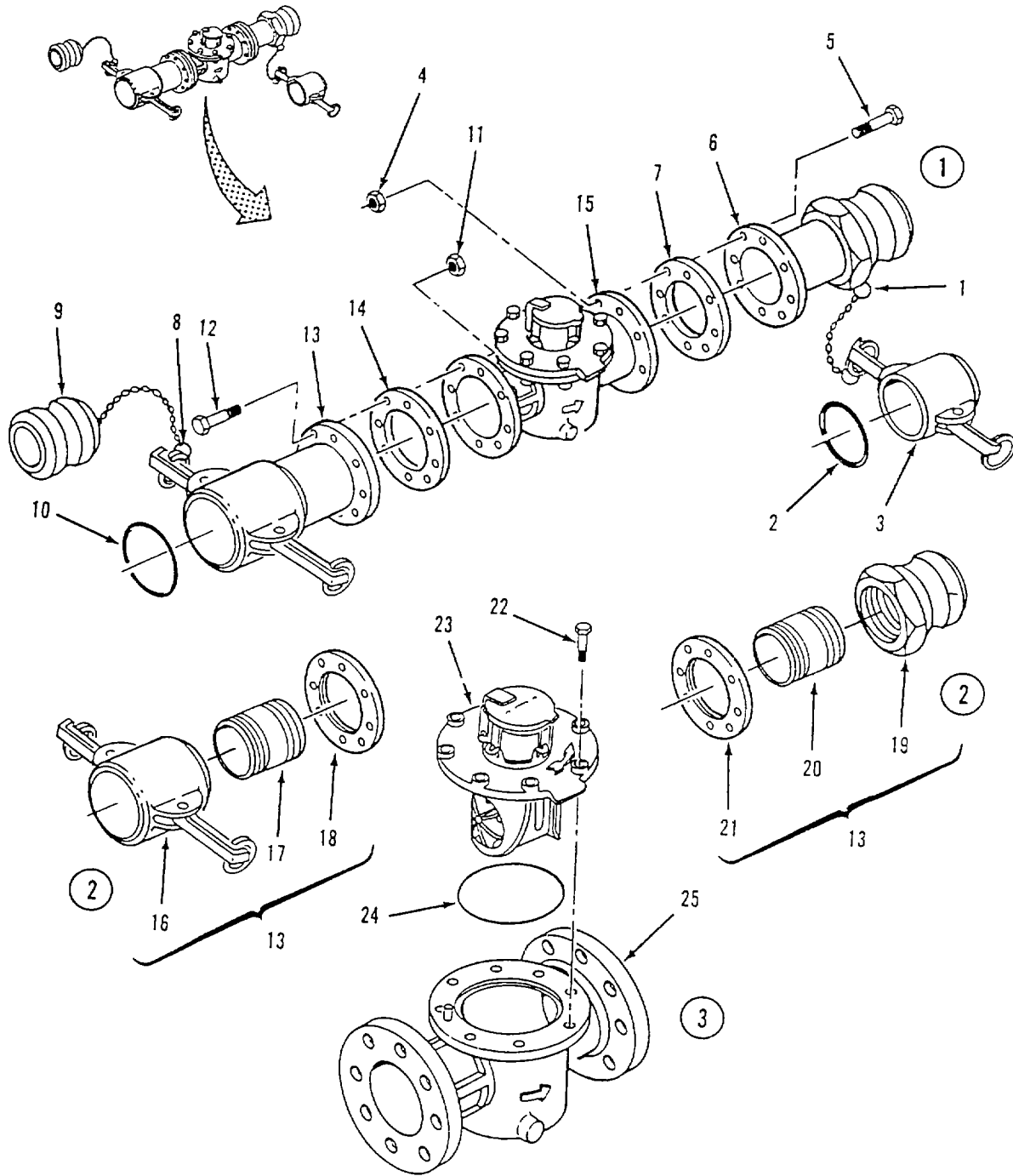

Figure 4-29. Water Meter Repair.

4-32. WATER METER ASSEMBLY REPAIR - cont.

(10) Position gasket (7) and male coupling (6) on meter (15).

(11) Install eight screws (5) and self locking nuts (4).

NOTE

Ensure packing is fully seated in groove of cap.

(12) Install gasket (2) in cap (3).

(13) Connect cap (3) to male coupling (9) with ring (1).

(14) Install water meter assembly in water system (para 3-4a).

(15) Startup water system (para 2-12c) and check water meter assembly for leaks.

4-32.1. WATER METER ASSEMBLY REPAIR (MODEL 800KWSDS).

This task consists of: a. Disassembly b. Cleaning c. Inspection
d. Repair e. Assembly

INITIAL SET-UP:**Tools:**

General Mechanics Tool Kit (Item 1, App B)

Equipment Condition:

Water meter assembly removed (para 3-4a)

Material/Parts:

Detergent, General Purpose (Item 1, App E)

Wiping Rag (Item 2, App E)

Gasket (2) (Item 4, App I)

Gasket, Flange (2) (Item 41, App I)

Gasket, Meter (Item 42, App I)

Self Locking Nut (16) (Item 40, App I)

NOTE

Ensure that all parts identified as mandatory replacement parts are discarded and replaced with new components.

a. Disassembly. Refer to figure 4-29.1.

(1) Disconnect ring (1) from female coupling (12) and remove plug (2).

NOTE

The two screws (5) that attach support bracket (7) to the flange of the water meter are longer than the other six screws (10) used on the flange.

(2) Remove two self locking nuts (3). flat washers (4), screws (5) and flat washers (6).

(3) Remove support bracket (7) from water meter body (27).

(4) Remove six self locking nuts (8), flat washers (9), screws (10) and flat washers (11).

4-32.1. WATER METER ASSEMBLY REPAIR (MODEL 800KWSDS) - cont.

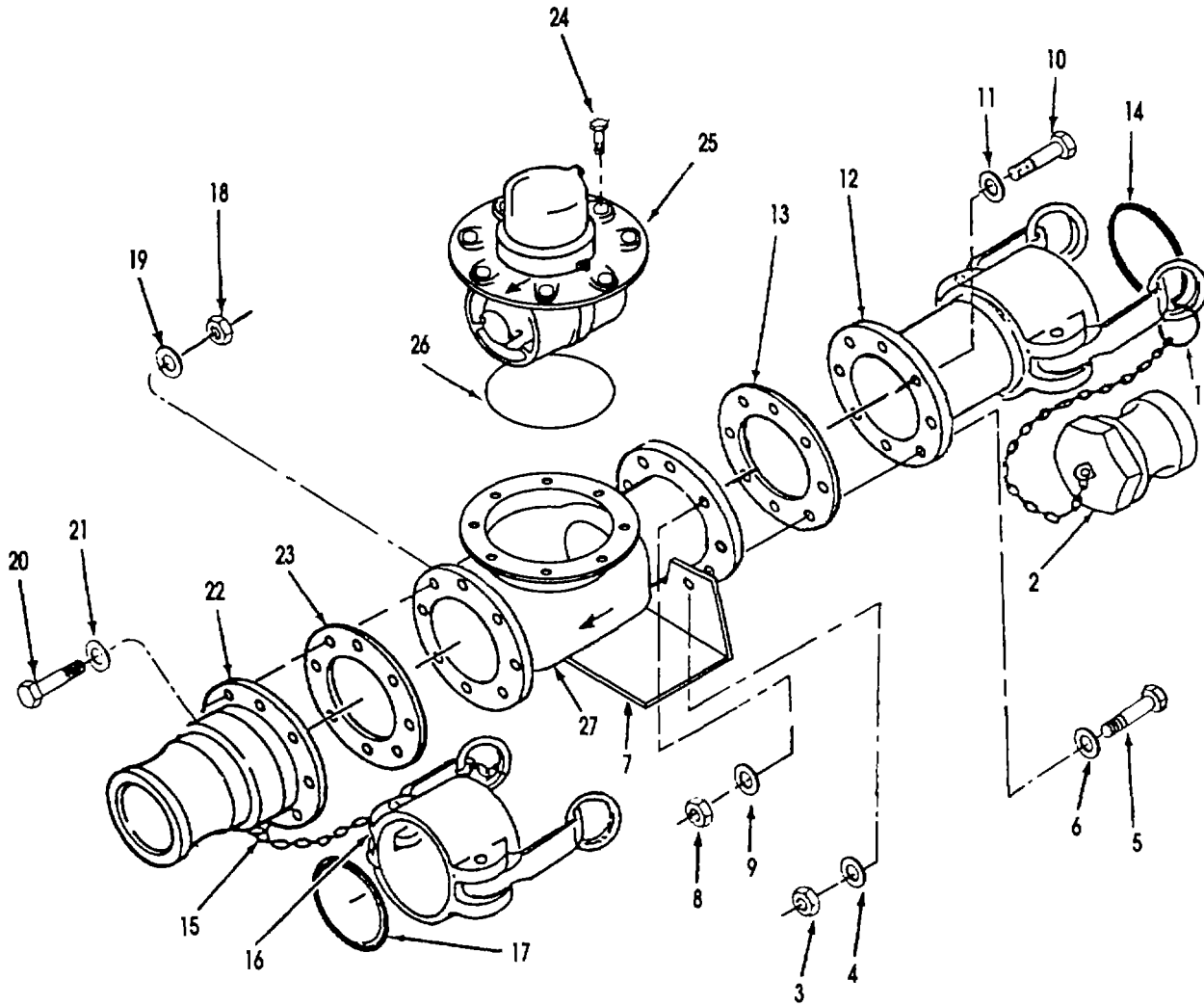

Figure 4-29.1 Water Meter Repair (Model 800KWSDS).

4-32.1. WATER METER ASSEMBLY REPAIR (MODEL 800KWSDS) - cont.

- (5) Remove female coupling (12) and gasket (13).
- (6) Remove gasket (14) from female coupling (12).
- (7) Disconnect ring (15) from male coupling (22) and remove cap (16).
- (8) Remove gasket (17) from cap (16).
- (9) Remove eight self locking nuts (18), flat washers (19), screws (20) and flat washers (21).
- (10) Remove male coupling (22) and gasket (23).
- (11) Remove 8 bolts (24).
- (12) Separate meter unit (25) and gasket (26) from meter maincase (27).

b. Cleaning.

- (1) Wash all components with clean water and detergent.
- (2) Rinse components in clean water and dry with wiping rag.

c. Inspection.

- (1) Inspect female coupling (12) and male coupling (22) for cracks and corrosion.
- (2) Inspect water meter maincase (27) for cracks, damage, and corrosion.
- (3) Inspect meter unit (25) for cracks, damage and corrosion.

d. Repair.

Replace damaged or defective parts. Replace gaskets (14 and 17), flange gaskets (13 and 23), meter gasket (26) and self locking nuts (3, 8 and 18).

e. Assembly. Refer to figure 4-29.1.

- (1) Position gasket (26) on meter maincase (27).
- (2) Lower meter unit (25) onto gasket (26) and meter maincase (27). Make sure arrow on top of the meter unit is pointing in the same direction as the arrow on the maincase.
- (3) Install 8 bolts (24).
- (4) Position gasket (23) and male coupling (22) on outlet flange of water meter maincase (27).
- (5) Install eight flat washers (21), screws (20), flat washers (19) and self locking nuts (18).

NOTE

Ensure gasket is fully seated in groove of cap.

- (6) Install gasket (17) in cap (16).

4-32.1. WATER METER ASSEMBLY REPAIR (MODEL 800KWSDS) - cont.

- (7) Connect cap (16) to male coupling (22) with ring (15).
- (8) Position gasket (13) and female coupling (12) on inlet flange of water meter maincase (27).

NOTE

The two screws (5) that attach support bracket (7) to the flange of the water meter are longer than the other six screws (10) used on the flange.

- (9) Install six flat washers (11), 3 1/4-inch long screws (10), flat washers (9) and self locking nuts (8).
- (10) Position support bracket (7) on water meter body (27).
- (11) Install two flat washers (6), 3 3/4-inch long screws (5), flat washers (4) and self locking nuts (3).

NOTE

Ensure gasket is fully seated in groove of female coupling.

- (12) Install gasket (14) in female coupling (12).
- (13) Connect plug (2) to female coupling (12) with ring (1).
- (14) Install water meter assembly in water system (para 3-4a).
- (15) Startup water system (para 2-12c) and check water meter assembly for leaks.

4-33. 125 GPM PUMP CONNECTION KIT MAINTENANCE.

The 125 gpm pump connection kit consists of the components listed below. Refer to the following paragraphs for applicable maintenance procedures.

Procedure	Para.
Discharge Hose Repair	4-14
Gate Valve Assembly (2-Inch) Repair	4-15
Check Valve Assembly (2-inch) Repair	4-34

4-34. CHECK VALVE (2-INCH) REPAIR.

This task consists of

a. Disassembly	b. Cleaning	c. Inspection
d. Repair	c. Assembly	

INITIAL SET-UP:**Tools:**

General Mechanics Tool Kit (Item 1, App B)
 Pipe Wrench (from accessory kit)
 Vice (Item 2, App B)

Equipment Condition:

Check valve assembly removed (para 3-4a)

Material/Parts:

Detergent, General Purpose (Item 1, App E)
 Wiping Rag (Item 2, App E)
 Tape, Anti-seize (Item 3, Appendix E)
 Gasket (2) (Item 3, App I)

NOTE

Ensure that all parts identified as mandatory replacement parts are discarded and replaced with new components.

- a. Disassembly. Refer to figure 4-30.
- (1) Place check valve assembly in vice.
 - (2) Using pipe wrench, remove male coupling (1) from assembled valve (4).
 - (3) Remove gasket (2) from female coupling (3).
 - (4) Using pipe wrench, unscrew female coupling (3) from assembled valve (4).
 - (5) Using pipe wrench, remove cap (5) from body (11).
 - (6) Remove plug (6) body (11).
 - (7) Pull pin (7) out from body (11) and lift out lever (10) and attached parts.
 - (8) Remove nut (8) and separate disc (9) front lever (10).
- b. Cleaning.
- (1) Wash all components with clean water and detergent.
 - (2) Rinse components in clean water and dry with wiping rag.

4-34. CHECK VALVE (2-INCH) REPAIR- cont.

c. Inspection.

- (1) Inspect body (11), male coupling (1), cap (5) and plug (6) for cracks, corrosion and stripped or damaged threads.
- (2) Inspect female coupling (3) for cracks and damaged locking arms.
- (3) Inspect disc (9) for cracks, distortion and scored sealing surface.

d. Repair. Replace damaged parts Do not reuse sealing components.e. Assembly.

- (1) Position disc (9) on lever (10) and Secure with nut (8).
- (2) Lower lever (10) and attached parts into body (11). Make sure sealing surface of disc (9) is positioned as shown.
- (3) While alining hole in lever (10) with hole in body (11), insert pin (7) through body and lever- Make sure pin is fully seated.

NOTE

Ensure that anti-seize tape is applied in the same direction as the treads.

- (4) Apply anti-seize tape to threads of plug (6) Install plug in body (11).
- (5) Apply anti-seize tape to threads of cap (5) Using pipe wrench, install cap (5) on body (11).
- (6) Apply anti-seize tape to threads of female coupling (3). Using pipe, screw female coupling into assembled valve (4).

NOTE

Ensure gasket is fully seated in groove of coupling.

- (7) Install gasket (2) in female coupling (3).
- (8) Apply anti-seize tape to threads of male coupling (1). Using pipe wrench, screw male coupling (1) into assembled valve (4).
- (9) Install check valve assembly in water system (para 3-4a).
- (10) Startup water system (para 2-12c) and inspect check valve assembly for leaks.

4-34. CHECK VAIVE (2-INCH) REPAIR - cont.

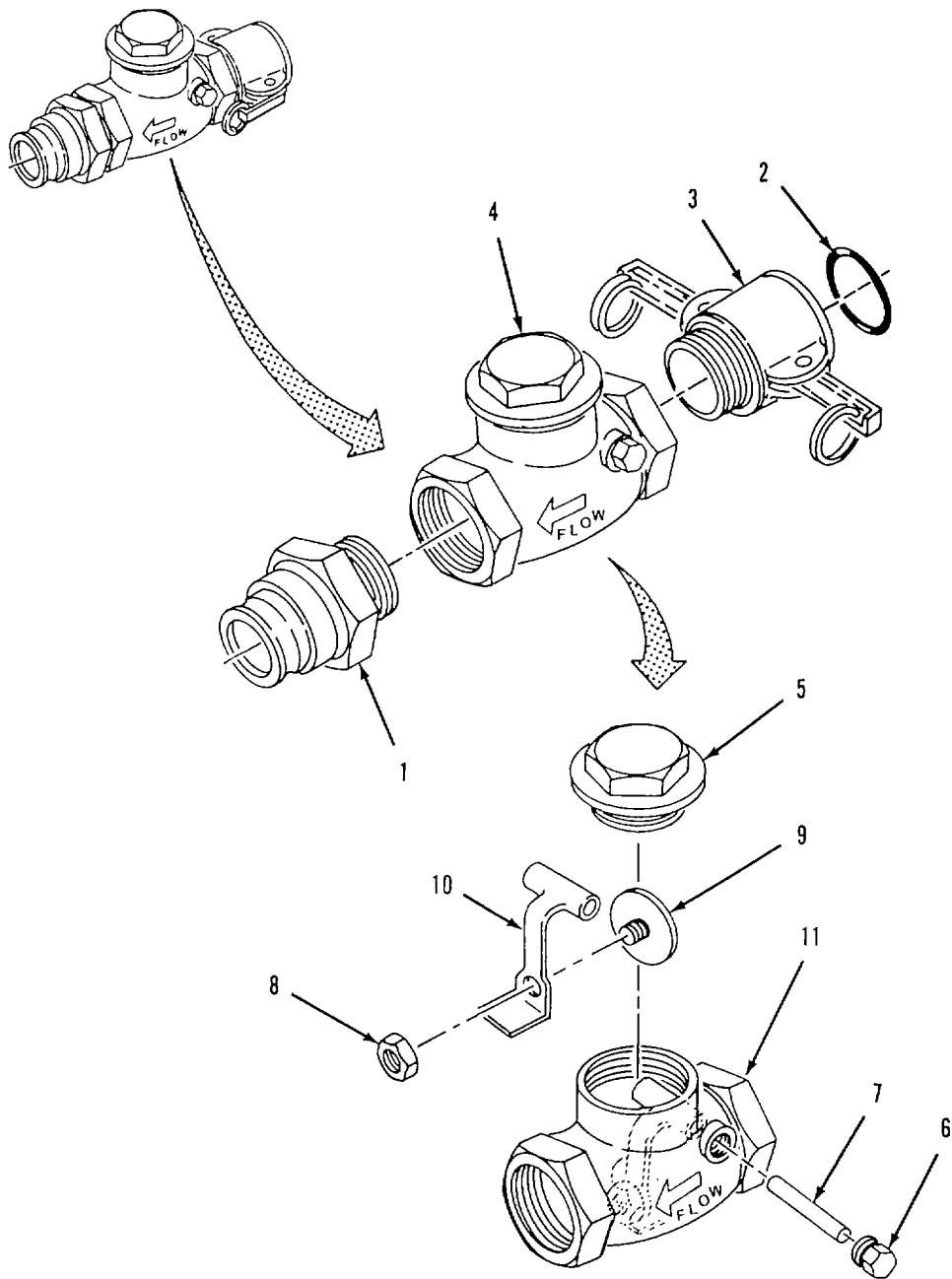

Figure 4-30. Check Valve Assembly (2-inch) Repair.

4-35. DUAL TANK CONNECTION KIT MAINTENANCE.

The dual tank connection kit consists of the components listed below. Refer to the following paragraphs for applicable maintenance procedures.

Procedure	Para.
Suction and Discharge Hose Repair.....	4-14
Tee and Gate Valve Assembly (9114-Y1) Repair	4-36
Tee and Gate Valve Assembly (9114-Y2) Repair	4-37
Tee and Gate Valve Assembly (9114-Y5) Repair	4-38
Tee and Gate Valve Assembly (9114-Y6) Repair	4-39

4-36. TEE AND GATE VALVE ASSEMBLY (9114-Y1) REPAIR.

This task consists of

a. Disassembly	b. Cleaning	c. Inspection
d. Repair	e. Assembly	

INITIAL SET-UP:	
<p>Tools: General Mechanics Tool Kit (Item 1, App B) Vice (Item 2, App B)</p> <p>Equipment Condition: Tee and gate valve assembly removed (para 3-4a)</p>	<p>Material/Parts: Detergent, General Purpose (Item 1, App E) Wiping Rag (Item 2, App E) Gasket (3) (Item 3, App I) Gasket (4) (Item 10, App I) Lockwashers (32) (Item 11, App I)</p>

NOTE

Ensure that all parts identified as mandatory replacement parts are discarded and replaced with new components.

- a. Disassembly. Refer to figure 4-31.
 - (1) Disconnect ring (1) from male coupling (9) and remove cap (3).
 - (2) Remove gasket (2) from cap (3).
 - (3) Remove eight nuts (4), lockwashers (5), flat washers (6), screws (7) and flat washers (8).
 - (4) Separate male coupling (9) and gasket (10) from gate valve (16).
 - (5) Remove eight nuts (11), lockwashers (12), flat washers (13), screws (14) and flat washers (15).
 - (6) Separate gate valve (16) and gasket (17) from tee (38).
 - (7) Disconnect ring (18) from female coupling (26) and remove plug (19).

4-36. TEE AND GATE VALVE ASSEMBLY (9114-Y1) REPAIR - cont.

(8) Remove gasket (20) from female coupling (26).

(9) Remove eight nuts (21), lockwashers (22), flat washers (23) and screws (24) and flat washers (25).

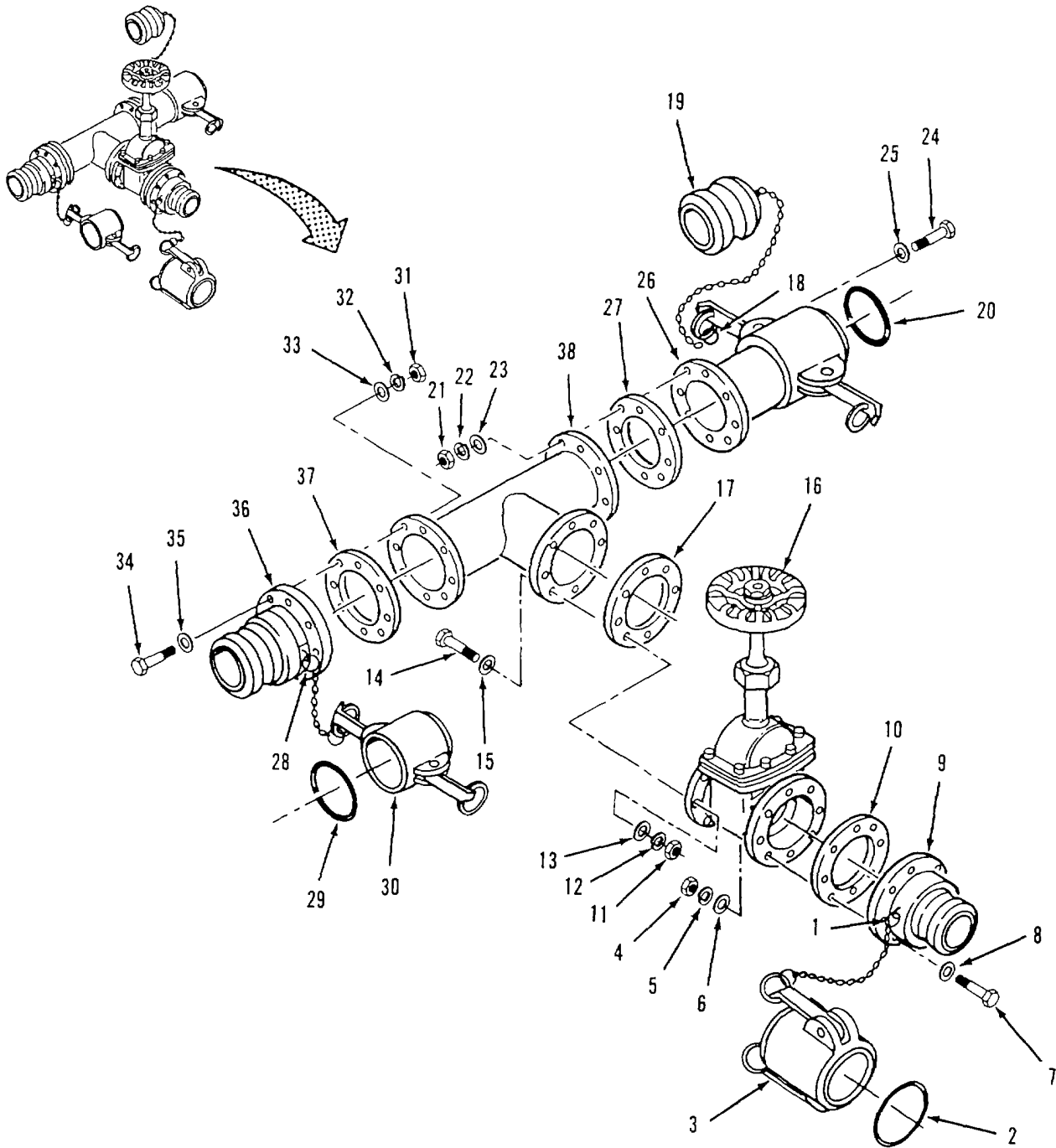

Figure 4-31. Tee and Gate Valve assembly (9114-Y1) Disassembly.

4-36. TEE AND GATE VALVE ASSEMBLY (9114-Y1) REPAIR - cont.

- (10) Separate female coupling (26) and gasket (27) from tee (38).
- (11) Disconnect ring (28) from male coupling (36) and remove cap (30).
- (12) Remove gasket (29) from cap (30).
- (13) Remove eight nuts (31), lockwashers (32), flat washers (33), screws (34) and flat washers (35).
- (14) Separate male coupling (36) and gasket (37) from tee (38)

b. Cleaning

- (1) Wash all components with clean water and detergent.
- (2) Rinse components in clean water and dry with wiping rag.

c. Inspection

- (1) Inspect male couplings (9 and 36) for cracks
- (2) Inspect female coupling (26) for cracks and damaged lock arms.
- (3) Inspect tee (38) for cracks and corrosion.

d. Repair.

- (1) Refer to para. 4-27 to repair gate valve.
- (2) Replace defective components Do not reuse sealing components.

e. Assembly. Refer to figure 4-32.

- (1) Position gasket (37) and male coupling (36) on tee (38).
- (2) Install eight flat washers (35), screws (34), flat washers (33), lockwashers (32) and nuts (31).

NOTE

Ensure gasket is fully seated in groove of cap.

- (3) Install gasket (29) in cap (30). Connect cap to male coupling (36) with ring (28).
- (4) Position gasket (27) and female coupling (26) on tee (38).
- (5) Install eight flat washers (25), screws (24), flat washers (23) lockwashers (22) and nuts (21).

NOTE

Ensure gasket is fully seated in groove of coupling.

- (6) Install gasket (20) in female coupling (26).

4-36. TEE AND GATE VALVE ASSEMBLY (9114-Y1) REPAIR - cont.

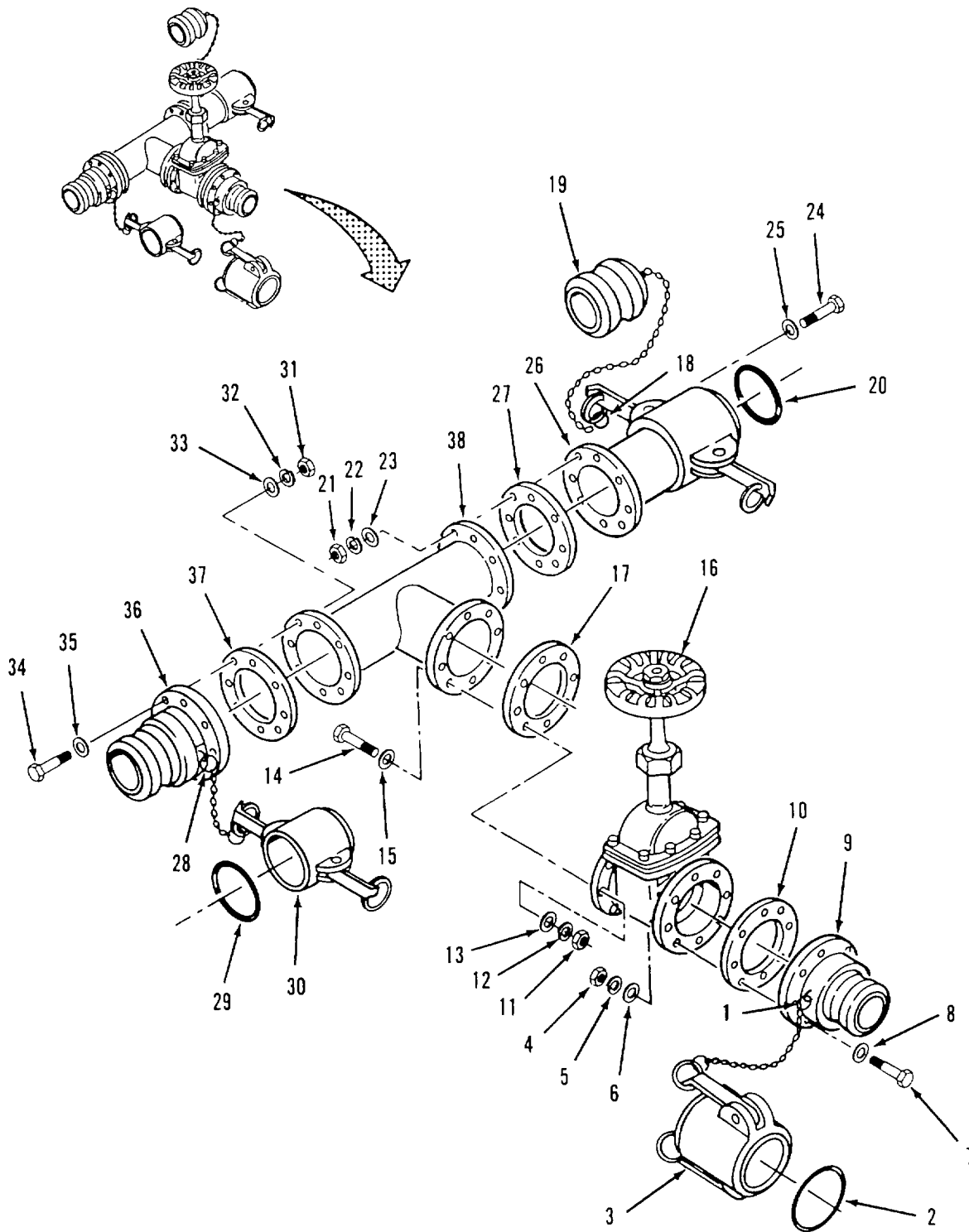

Figure 4-32. Tee and Gate Valve Assembly (9114-Y1) Assembly.

4-36. TEE AND GATE VALVE ASSEMBLY (9114-Y1) REPAIR - cont.

- (7) Connect plug (19) to female coupling (26) with ring (18).
- (8) Position gasket (17) and gate valve (16) on tee (38).
- (9) Install eight flat washers (15), screws (14), flat washers (13) lockwashers (12) and nuts (11).
- (10) Position gasket (10) and male coupling (9) on gate valve (16).
- (11) Install eight flat washers (8), screws (7), flat washers (6), lockwashers (5) and nuts (4).

NOTE

Ensure gasket is fully seated in groove of cap.

- (12) Install gasket (2) in cap (3).
- (13) Connect cap (3) to male coupling (9) with ring (1).
- (14) Install tee and gate valve assembly in water system (para 3-4a).
- (15) Startup water system (para 2-12c) and check tee and gate valve assembly for leaks.

4-37. TEE AND GATE VALVE ASSEMBLY (9114-Y2) REPAIR.

This task consists of. a. Disassembly b. Cleaning c. Inspection
 d. Repair e. Assembly

INITIAL SET-UP:

Tools:

General Mechanics Tool Kit (Item 1, App B)
 Vice (Item 2, App B)

Equipment Condition:

Tee and gate valve assembly removed (para 3-4a)

Material/Parts:

Detergent, General Purpose (Item 1, App E)
 Wiping Rag (Item 2, App E)
 Gasket (3) (Item 3, App I)
 Gasket (4) (Item 10, App I)
 Lockwashers (32) (Item 11, App I)

NOTE

Ensure that all parts identified as mandatory replacement parts are discarded and replaced with new components.

- a. Disassembly. Refer to figure 4-33.
 - (1) Remove eight nuts (1), lockwashers (2), flat washers (3), screws (4) and flat washers (5).
 - (2) Separate male coupling (6) and gasket (7) from gate valve (13).

4-37. TEE AND GATE VALVE ASSEMBLY (9114-Y2) REPAIR - cont.

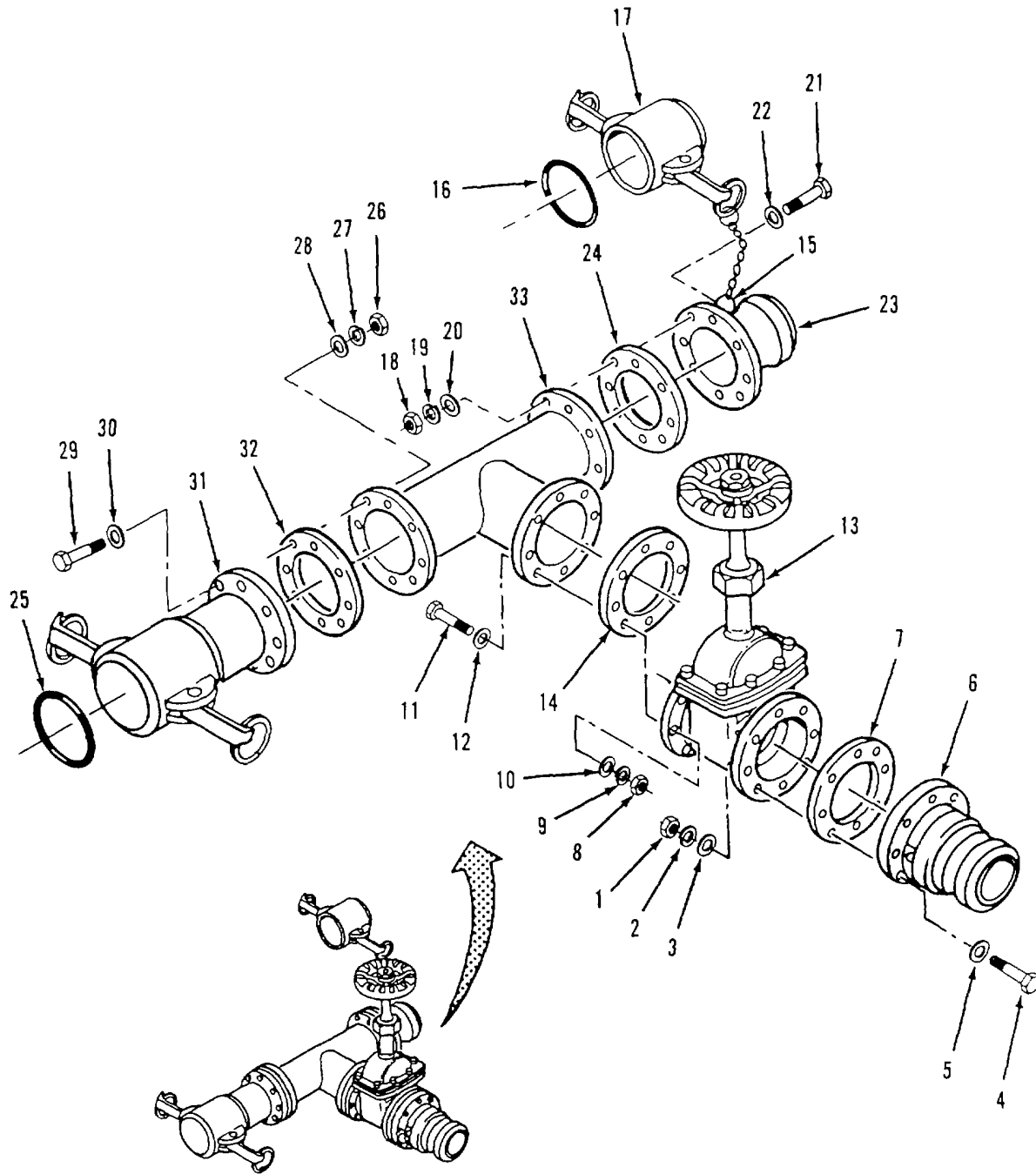

Figure 4-33. Tee and Gate Valve Assembly (9114-Y2) Disassembly.

4-37. TEE AND GATE VALVE ASSEMBLY (9114-Y2) REPAIR - cont.

- (3) Remove eight nuts (8), lockwasher-s (9), flat washers (10), screws (11) and flat washers (12).
- (4) Separate gate valve (13) and gasket (14) from tee (33).
- (5) Disconnect ring (15) from male coupling (23) and remove cap (17).
- (6) Remove gasket (16) from cap (17).
- (7) Remove eight nuts (18), lockwashers (19), flat washers (20), screws (21) and flat washers (22).
- (8) Separate male coupling (23) and gasket (24) from tee (33).
- (9) Remove gasket (25) from female coupling (31).
- (10) Remove eight nuts (26), lockwashers (27), flat washers (28) and screws (29) and flat washers (30).
- (11) Separate female coupling (31) and gasket (32) from tee (33)-

b. Cleaning.

- (1) Wash all components with clean water and detergent.
- (2) Rinse components in clean water and dry with wiping rag.

c. Inspection.

- (1) Inspect male couplings (6 and 23) for cracks.
- (2) Inspect female Coupling (31) for cracks and damaged lock arms.
- (3) Inspect tee (33) for cracks and corrosion.

d. Repair.

- (1) Refer to para. 4-27 to repair gate valve.
- (2) Replace defective components. Do not reuse sealing components.

c. Assembly. Refer to figure 4-34.

- (1) Position gasket (32) and female coupling (31) on tee (33).
- (2) Install eight flat washers (30), screws (29), fat washers (28) lockwashers (27) and nuts (26).

4-37. TEE AND GATE VALVE ASSEMBLY (9114-Y2) REPAIR - cont.

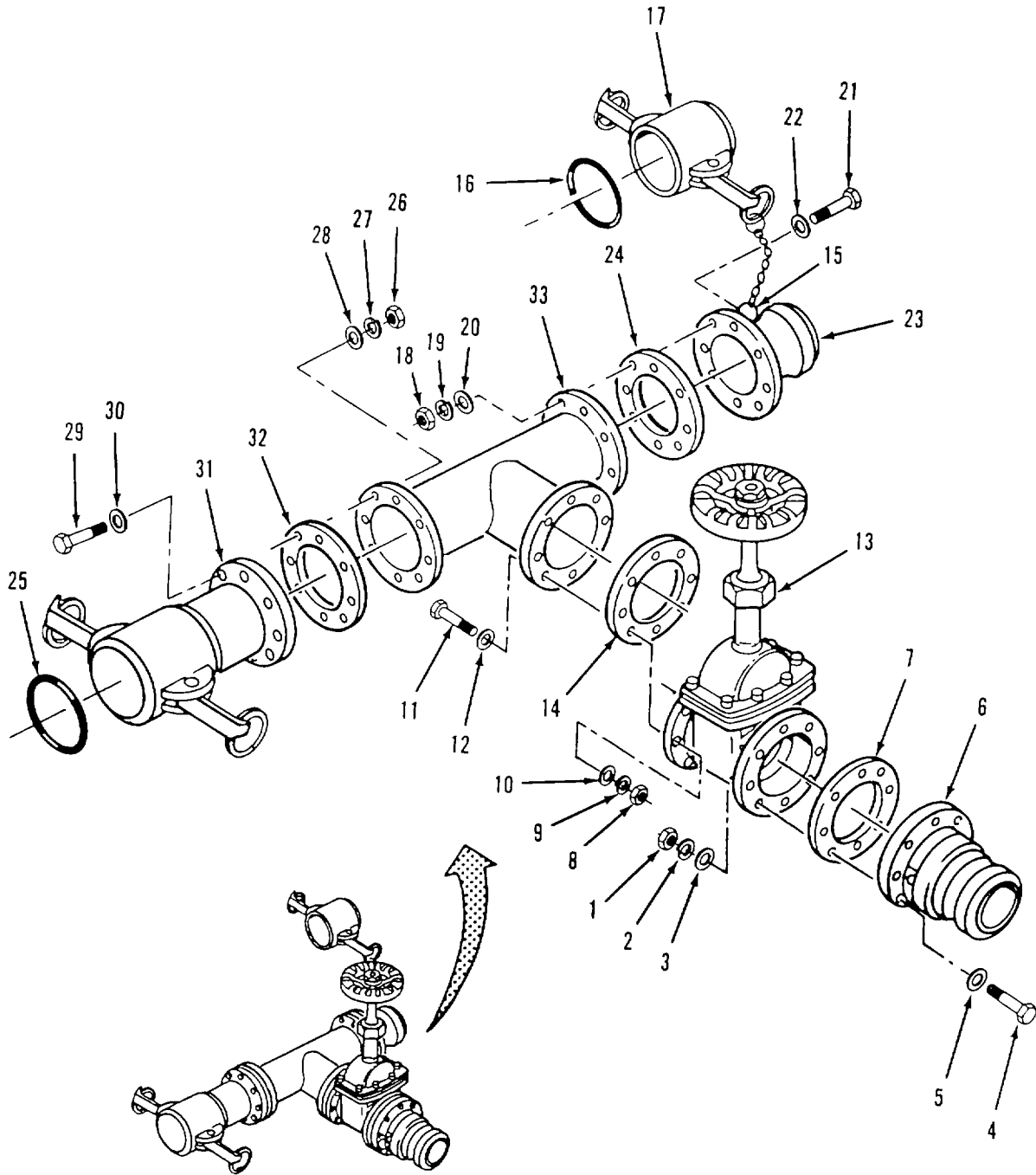

Figure 4-34. Tee and Gate Valve Assembly (9114-Y2) Assembly.

4-37. TEE AND GATE VALVE ASSEMBLY (9114-Y2) REPAIR - cont.

NOTE

Ensure- gasket is fully seated in groove of coupling.

- (3) Install gasket (25) in female coupling (31).
- (4) Position gasket (24) and male coupling (23) on tee (33).
- (5) Install eight flat washers (22), screws (21), flat washers (20), lockwashers (19) and nuts (18).

NOTE

Ensure gasket is fully seated in groove of cap.

- (6) Install gasket(16) in cap (17). Connect cap to male coupling(23) with ring(15).
- (7) Position gasket (14) and gate valve (13) on tee (33).
- (8) Install eight flat washers (12), screws (11), flat washers (10) lockwashers (9) and nuts (8).
- (9) Position gasket (7) and male coupling (6) on gate valve (13).
- (10) Install eight flat washers (5), screws (4), flat washers (3), lock washers (2) and nuts (1).
- (11) Install tee and gate valve assembly in water system (para 3-4a).
- (12) Startup water system (para 2-12c) and check tee and gate valve assembly for leaks.

4-38. TEE AND GATE VALVE ASSEMBLY (9114-Y5) REPAIR.

- This task consists of:
- a. Disassembly
 - b. Cleaning
 - c. Inspection
 - d. Repair
 - e. Assembly

INITIAL SET-UP:

Tools:

- General Mechanics Tool Kit (Item 1, App B)
- Vice (Item 2, App B)

Equipment Condition:

- Tee and gate valve assembly removed (para 3-4a)

Material/Parts:

- Detergent, General Purpose (Item 1, App E)
- Wiping Rag (Item 2, App E)
- Gasket (3) (Item 3, App I)
- Gasket (4) (Item 10, App I)
- Lockwashers (32) (Item 11, App I)

NOTE

Ensure that all parts identified as mandatory replacement parts are discarded and replaced with new components

- a. Disassembly. Refer to figure 4-35.
 - (1) Disconnect ring (1) from female coupling (9) and remove plug (2).

4-38. TEE AND GATE VALVE ASSEMBLY (9114-Y5) REPAIR - cont.

- (2) Remove gasket (3) from female coupling (9).
- (3) Remove eight nuts (4), lockwashers (5), flat washers (6), screws (7) and ten flat washers (8).
- (4) Separate female coupling (9) and gasket (10) from gate valve (16).
- (5) Remove eight nuts (11), lockwashers (12), flat washers (13), screws (14) and flat washers (15).
- (6) Separate gate valve (16) and gasket (17) from tee (38).
- (7) Disconnect ring (18) from male coupling (26) and remove cap (20).
- (8) Remove gasket (19) from cap (20).
- (9) Remove eight nuts (21), lockwashers (22), flat washers (23), screws (24) and flat washers (25).
- (10) Separate male coupling (26) and gasket (27) from tee (38).
- (11) Disconnect ring (28) from female coupling (36) and remove plug (29).
- (12) Remove gasket (30) from female coupling (36).
- (13) Remove eight nuts (31), lockwashers (32), flat washers (33) and screws (34) and flat washers (35).
- (14) Separate female coupling (36) and gasket (37) from tee (38).

b. Cleaning.

- (1) Wash all components with clean water and detergent.
- (2) Rinse components in clean water and dry with wiping rag.

c. Inspection.

- (1) Inspect male couplings (26) and tee (38) for cracks.
- (2) Inspect female coupling (9 and 36) for cracks and damaged lock arms.

4-38. TEE AND GATE VALVE ASSEMBLY (9114-Y5) REPAIR - cont.

d. Repair.

- (1) Refer to para. 4-31 to repair gate valve.
- (2) Replace defective components. Do not reuse scaling components.

e. Assembly. Refer to figure 4-35.

- (1) Position gasket (37) and female coupling (36) on tee (38).
- (2) Install eight flat washers (35), screws (34), flat washers (33) lockwashers (32) and nuts (31).

NOTE

Ensure gasket is fully seated in groove of coupling.

- (3) Install gasket (30) in female coupling (36).
- (4) Connect plug (29) to female coupling (36) with ring (28).
- (5) Position gasket (27) and male coupling (26) on tee (38).
- (6) Install eight flat washers (25), screws (24), flat washers (23), lockwashers (22) and nuts (21).

NOTE

Ensure gasket is fully seated in groove of cap.

- (7) Install gasket (19) in cap (20) Connect cap to male coupling (26) with ring (18).
- (8) Position gasket (17) and gate valve (16) on tee (38).

NOTE

Two flat washers must be installed under heads of both top attaching screws when installing gate valve. Refer to Figure 4-27 for position of screws and double washers.

- (9) Install ten flat washers (15), eight screws (14), flat washers(13) lockwashers(12) and nuts (11).
- (10) Position gasket (10) and female coupling (9) on gate valve (16).
- (11) Install ten flat washers (8), eight screws (7), flat washers (6), lockwashers (5) and nuts (4).

NOTE

Ensure gasket is fully seated in groove of coupling.

- (12) Install gasket (3) in female coupling (9).
- (13) Connect plug (2) to female coupling (9) with ring (1).

4-38. TEE AND GATE VALVE ASSEMBLY (9114-Y5) REPAIR - cont.

- (14) Install tee and gate valve assembly in water system (para 3-4a).
- (15) Start up water system (para 2-12c) and check tee and gate valve assembly for leaks.

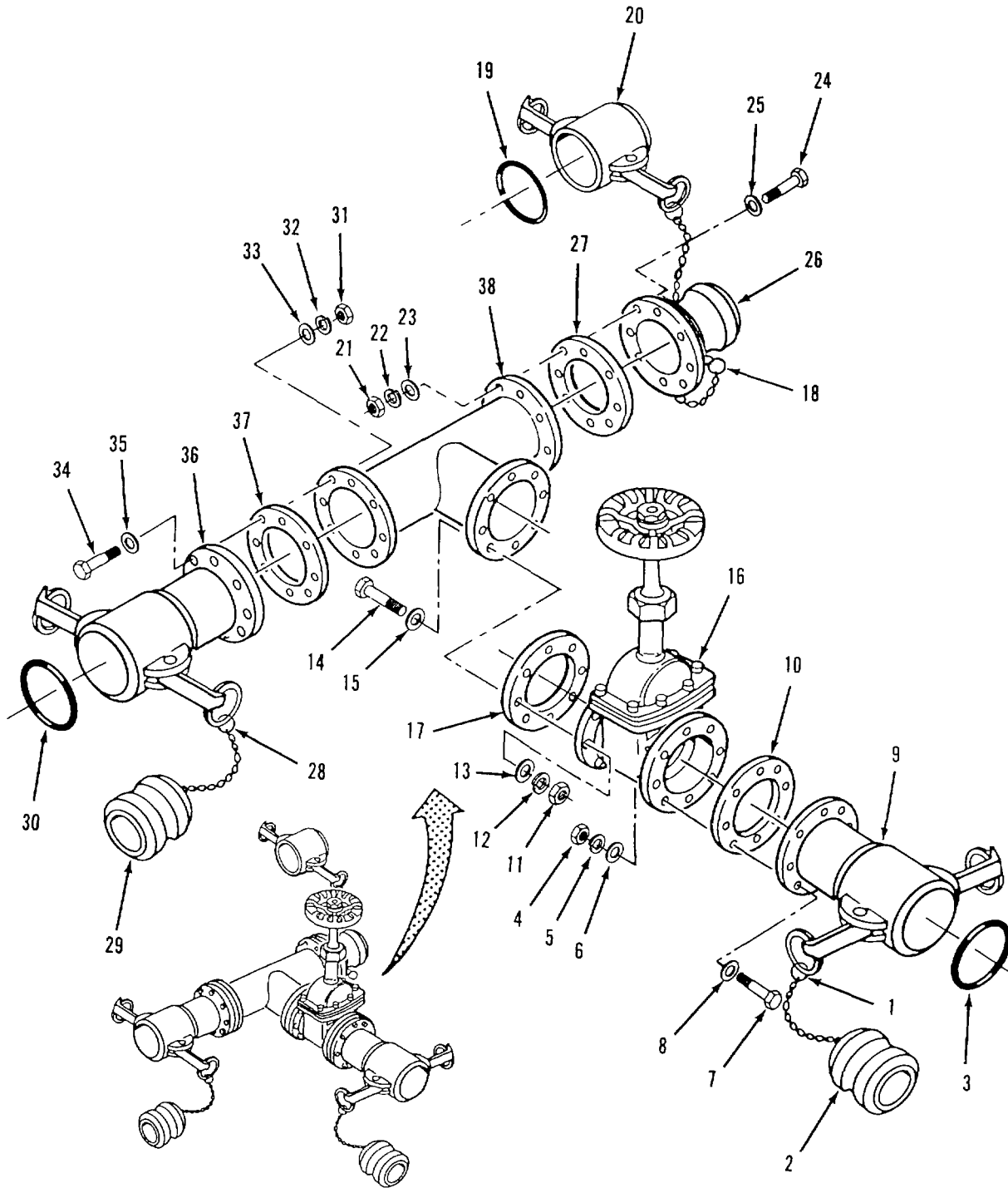

Figure 4-35. Tee and Gate Valve Assembly (9114-Y5) Repair.

4-39. TEE AND GATE VALVE ASSEMBLY (9114-Y6) REPAIR.
--

This task consists of:

a. Disassembly	b. Cleaning	c. Inspection
d. Repair	e. Assembly	

INITIAL SET-UP:	
<p>Tools: General Mechanics Tool Kit (Item 1, App B) Vice (Item 2, App B)</p> <p>Equipment Condition: Tee and gate valve assembly removed (para 3-4a)</p>	<p>Material/Parts: Detergent, General Purpose (Item 1, App E) Wiping Rag (Item 2, App E) Gasket (3) (Item 3, App I) Gasket (4) (Item 10, App I) Lockwashers (32) (Item 11, App I)</p>

NOTE

Ensure that all parts identified as mandatory replacement parts are discarded and replaced with new components.

- a. Disassembly. Refer to figure 4-36.
- (1) Disconnect ring (1) from female coupling (9) and remove plug (2).
 - (2) Remove gasket (3) from female coupling (9).
 - (3) Remove eight nuts (4), lockwashers (5), flat washers (6), screws (7) and flat washers (8).
 - (4) Separate female coupling (9) and gasket (10) from gate valve (16).
 - (5) Remove eight nuts (11), lockwashers (12), flat washers (13), screws (14) and flat washers (15).
 - (6) Separate gate valve (16) and gasket (17) from tee (38).
 - (7) Disconnect ring (18) from female coupling (26) and remove plug (19).
 - (8) Remove gasket (20) from female coupling (26).
 - (9) Remove eight nuts (21), lockwashers (22), flat washers (23) and screws (24) and flat washers (25).
 - (10) Separate female coupling (26) and gasket (27) from tee (38).
 - (11) Disconnect ring (28) from male coupling (36) and remove cap (30). Remove gasket (29) from cap.
 - (12) Remove eight nuts (31), lockwashers (32), flat washers (33), screws (34) and flat washers (35).
 - (13) Separate male coupling (36) and gasket (37) from tee (38).

4-39. TEE AND GATE VALVE, ASSEMBLY (9114-Y6) REPAIR - cont.

b. Cleaning.

- (1) Wash all components with clean water and detergent.
- (2) Rinse components in clean water and dry with wiping rag.

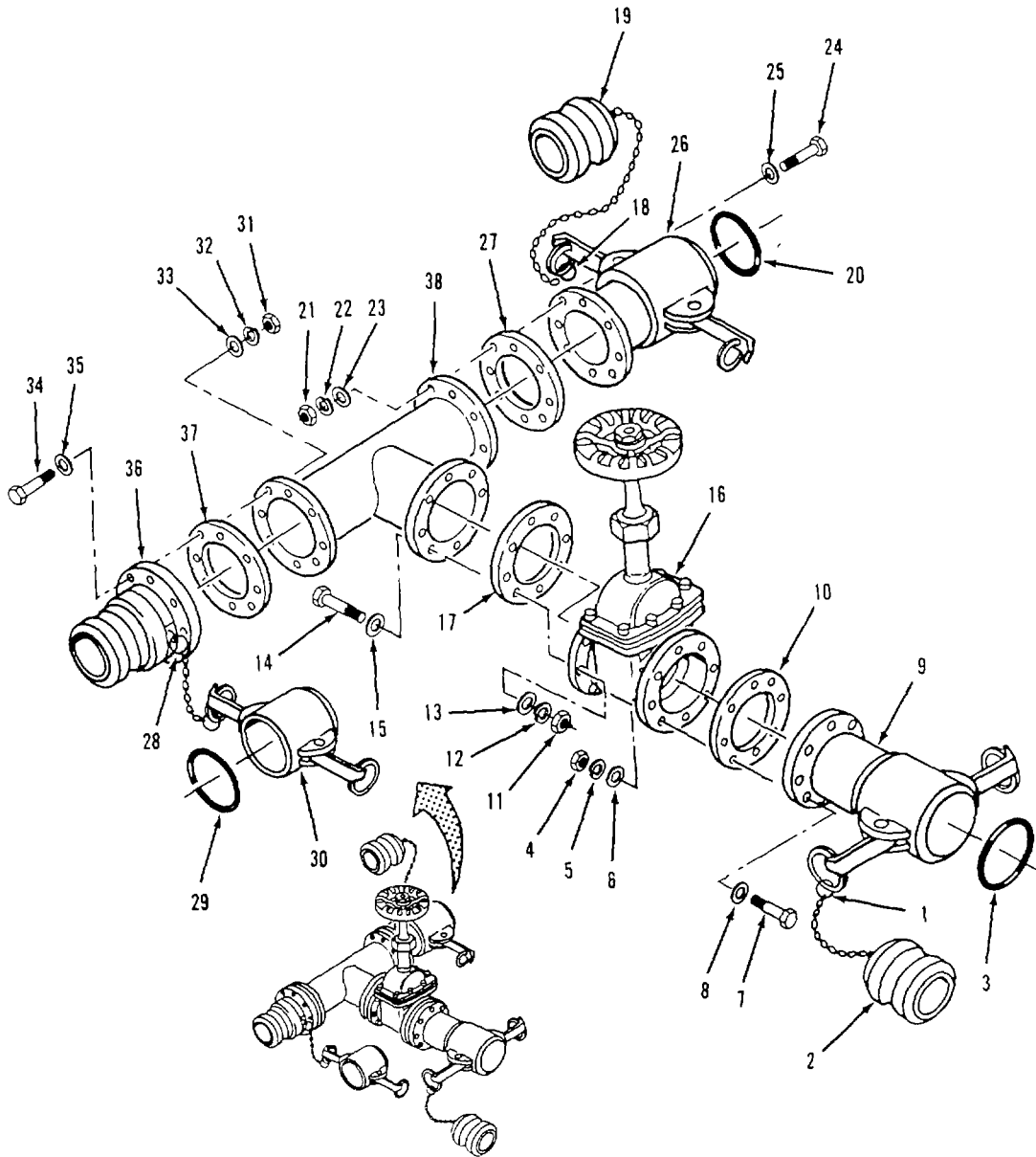

Figure 4-36. Tee and Gate Valve Assembly (9114-Y6) Disassembly.

4-39. TEE AND GATE VALVE ASSEMBLY (9114-Y6) REPAIR - cont.c. Inspection.

- (1) Inspect male couplings (36) for cracks.
- (2) Inspect female coupling (9 and 26) for cracks and damaged lock arms.
- (3) Inspect tee (38) for cracks and corrosion.

d. Repair.

- (1) Refer to para. 4-31 to repair gate valve.
- (2) Replace defective components. Do not reuse sealing components.

e. Assembly. Refer to figure 4-37.

- (1) Position gasket (37) and male coupling (36) on tee (38).
- (2) Install eight flat washers (35), screws (34), flat washers (33), lockwashers (32) and nuts (31).

NOTE

Ensure gasket is fully seated in groove of cap.

- (3) Install gasket (29) in cap (30) Connect cap to male coupling (36) with ring (28).
- (4) Position gasket (27) and female coupling (26) on tee (38).
- (5) Install eight flat washers (25), screws (24), flat washers (23) lockwashers (22) and nuts (21).

NOTE

Ensure gasket is fully seated in groove of coupling.

- (6) Install gasket (20) in female coupling (26).
- (7) Connect plug (19) to female coupling (26) with ring (18).
- (8) Position gasket (17) and gate valve (16) on tee (38).

NOTE

Two flat washers must be installed under heads of both top attaching screws on both sides of gate valve Refer to figure 4-27 for position of screws and double washers

- (9) Install ten flat washers (15), eight screws (14), flat washers (13), lockwashers (12) and nuts (11).
- (10) Position gasket (10) and female coupling (9) on gate valve (16).
- (11) Install eight flat washers (8), screws (7), flat washers (6), lockwashers (5) and nuts (4).

4-39. TEE AND GATE VALVE ASSEMBLY (9114-Y6) REPAIR - cont.

NOTE

Ensure gasket is fully seated in groove of coupling.

- (12) Install gasket (3) in female coupling (9).
- (13) Connect plug (2) of male coupling (9) with ring (1).
- (14) Install tee and gate valve assembly in water system (para 3-4a).
- (15) Startup water system (para 2-12c) and check tee and gate valve assembly for leaks.

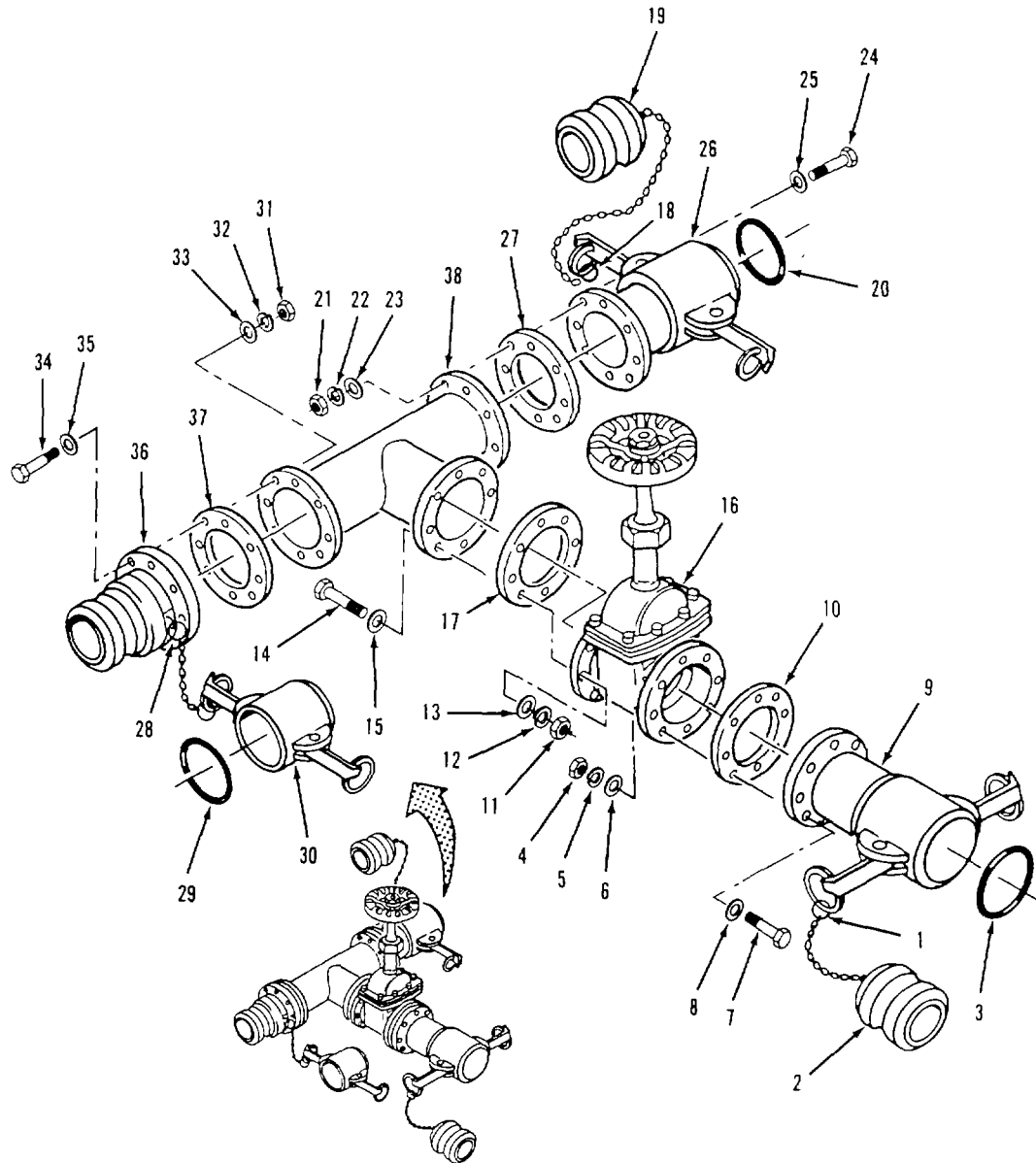

Figure 4-37. Tee and Gate Valve Assembly (9114-Y6) Assembly.

4-40. INTERCONNECTION KIT MAINTENANCE.

The interconnection kit consists of the components listed below Refer to the following paragraphs for applicable maintenance procedures.

Procedure	Para
Discharge Hose Repair	4-14
Tee Assembly (9115-Y) Repair	4-41
Tee Assembly (9115-Y1) Repair.....	4-42

4-41. TEE ASSEMBLY (9115-Y) REPAIR.

- This task consists of:
- | | | |
|----------------|-------------|---------------|
| a. Disassembly | b. Cleaning | c. Inspection |
| d. Repair | e. Assembly | |

INITIAL SET-UP:	
<p>Tools: General Mechanics Tool Kit (Item 1, App B)</p> <p>Equipment Condition: Tee assembly removed (para 3-4a)</p> <p>Material/Parts: Detergent, General Purpose (Item 1, App E)</p>	<p>Wiping Rag (Item 2, App E) Tape, Anti-seize (Item 3, Appendix E) Gasket (2) (Item 4, App I) Gasket (3) (Item 10, App I) Lockwashers (24) (Item 11, App I)</p>

NOTE

Ensure that all parts identified as mandatory replacement parts are discarded and replaced with new components.

- a. Disassembly. Refer to figure 4-38.
 - (1) Disconnect ring (1) from female coupling (9) and remove plug (2).
 - (2) Remove gasket (3) from female coupling (9).
 - (3) Remove eight nuts (4), lockwashers (5), flat washers (6) and screws (7) and flat washers (8).
 - (4) Separate female coupling (9) and gasket (10) from tee (29).
 - (5) Remove gasket (11) from female coupling (17).
 - (6) Remove eight nuts (12), lockwashers (13), flat washers (14), screws (15) and flat washers (16).
 - (7) Separate female coupling (17) and gasket (18) from tee (29).
 - (8) Disconnect ring (19) from male coupling (27) and remove cap (21).
 - (9) Remove gasket (20) from cap (21).

4-41. TEE ASSEMBLY (9115-Y) REPAIR - cont.

- (10) Remove eight nuts (22), lockwashers (23), flat washers (24) and screws (25) and flat washers (26).
- (11) Separate male coupling (27) and gasket (28) from tee (29).

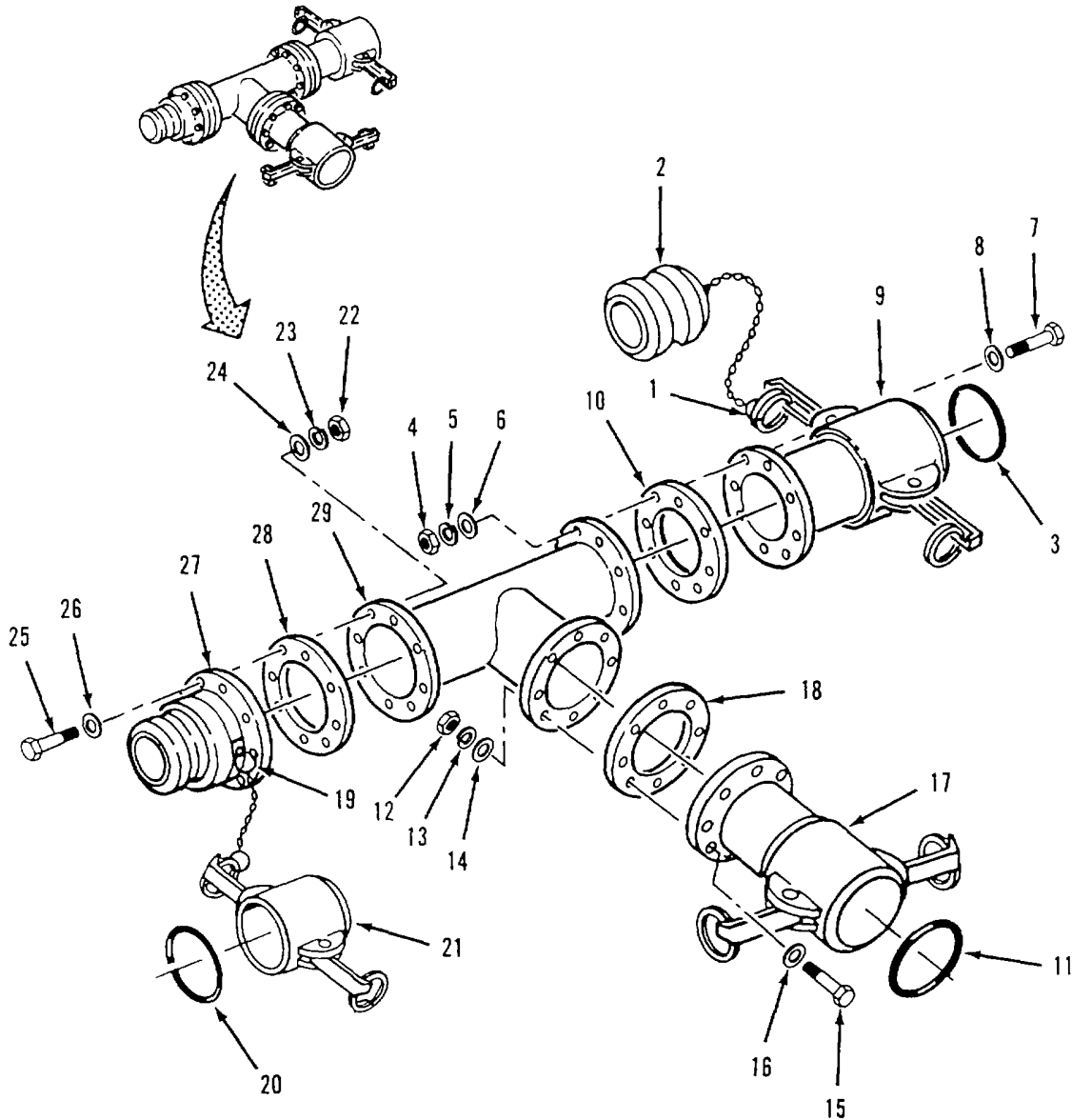

Figure 4-38. Tee Assembly (9115-Y) Disassembly.

4-41. TEE ASSEMBLY (9115-Y) REPAIR - cont.b. Cleaning.

- (1) Wash all components with clean water and detergent.
- (2) Rinse components in clean water and dry with wiping rag.

c. Inspection.

- (1) Inspect male coupling (27) for cracks.
- (2) Inspect female couplings (9 and 17) for cracks and damaged lock arms.
- (3) Inspect tee (29) for cracks and corrosion.

d. Repair. Replace defective components. Do not reuse sealing components.e. Assembly. Refer to figure 4-39.

- (1) Position gasket (28) and male coupling (27) on tee (29).
- (2) Install eight flat washers (26), screws (25), flat washers (24) lock washers (23) and nuts (22).

NOTE

Ensure gasket is fully seated in groove of cap.

- (3) Install gasket (20) in cap (21).
- (4) Connect cap (21) to male coupling (27) with ring (19).
- (5) Position gasket (18) and female coupling (17) on tee (29).
- (6) Install eight flat washers (16), screws (15), flat washers (14), lockwashers (13) and nuts (12).

NOTE

Ensure gasket is fully seated in groove of coupling.

- (7) Install gasket (11) in female coupling (17).
- (8) Position gasket (10) and female coupling (9) on tee (29).
- (9) Install eight flat washers (8), screws (7), flat washers (6) lockwashers (5) and nuts (4).

NOTE

Ensure gasket is fully seated in groove of coupling.

- (10) Install gasket (3) in female coupling (9).
- (11) Connect plug (2) to female coupling (9) with ring (1).

4-41. TEE ASSEMBLY (9115-Y) REPAIR - cont.

- (12) Install tee assembly in water system (para 3-4a)
- (13) Startup water system (para 2-12c) and check tee assembly for leaks.

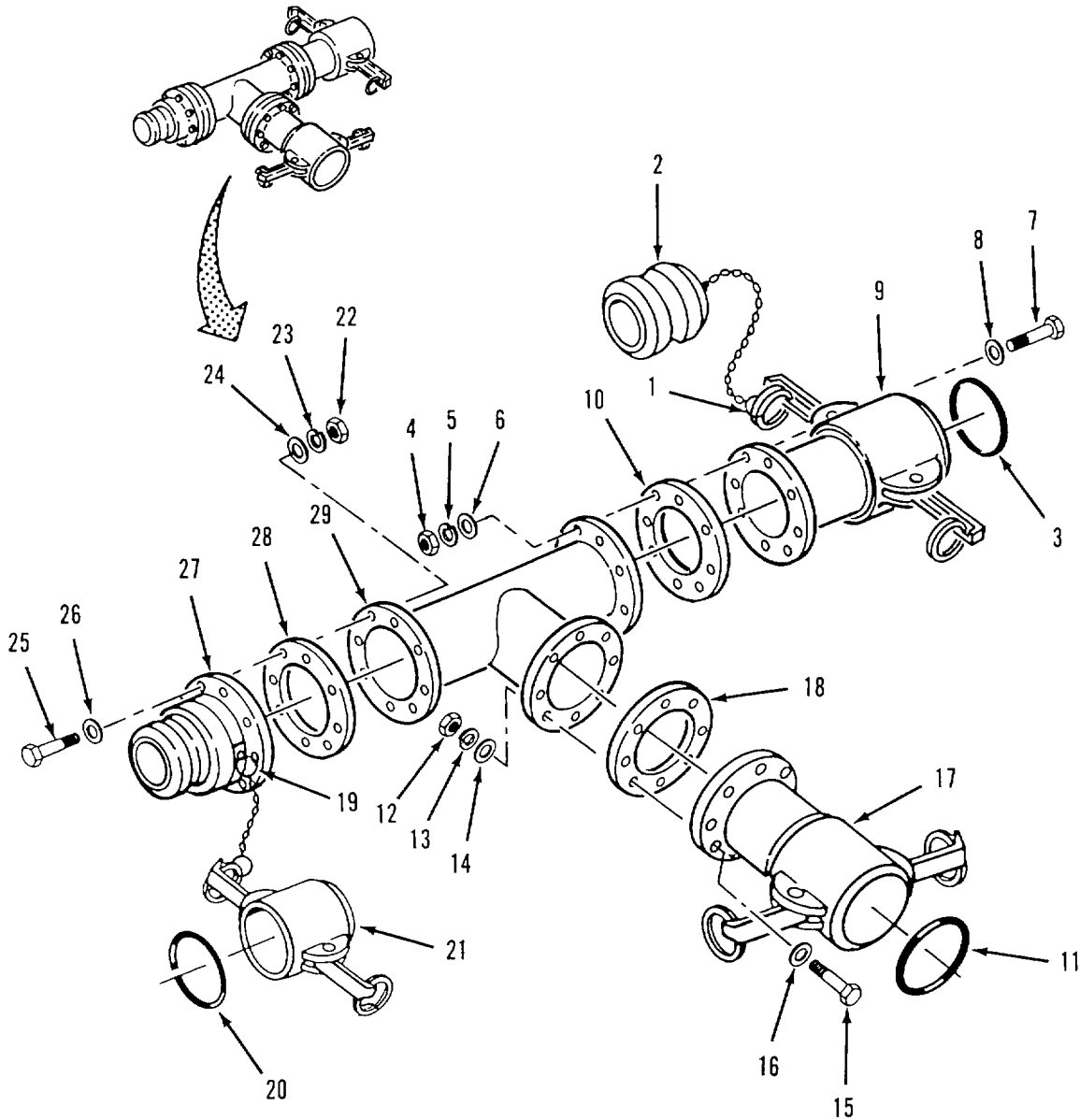

Figure 39. Tee Assembly (9115-Y) Assembly.

4-42. TEE ASSEMBLY (9115-Y1) REPAIR.

This task consists of:	a. Disassembly d. Repair	b. Cleaning e. Assembly	c. Inspection
------------------------	-----------------------------	----------------------------	---------------

INITIAL SETUP:

Tools: General Mechanics Tool Kit (Item 1, App B)	Wiping Rag (Item 2, App B) Tape, Anti-seize (Item 3, Appendix E)
Equipment Condition: Tee assembly removed (para 3-4a)	Gasket (2) (Item 4, App I) Gasket (3) (Item 10, App I)
Material/Parts: Detergent, General Purpose (Item 1, App E)	Lockwasher (24) (Item 11, App I)

a. Disassembly. Refer to figure 4-40.

- (1) Disconnect ring (1) from male coupling (9) and remove cap (3).
- (2) Remove gasket (2) from cap (3).
- (3) Remove eight nuts (4), lockwashers (5), flat washers (6) and screws (7) and flat washers (8).
- (4) Separate male coupling (9) and gasket (10) from tee (28).
- (5) Remove eight nuts (11), lockwashers (12), flat washers (13), screws (14) and flat washers (15).
- (6) Separate male coupling (16) and gasket (17) from tee (28).
- (8) Disconnect ring (18) from female coupling (26) and remove plug (19).
- (9) Remove gasket (20) from female coupling (26).
- (10) Remove eight nuts (21), lockwashers (22), flat washers (23) and screws (24) and flat washers (25).
- (11) Separate female coupling (26) and gasket (27) from tee (28).

b. Cleaning

- (1) Wash all components with clean water and detergent.
- (2) Rinse components in clean water and dry with wiping rag.

4-42. TEE ASSEMBLY (9115-Y1) REPAIR - cont.

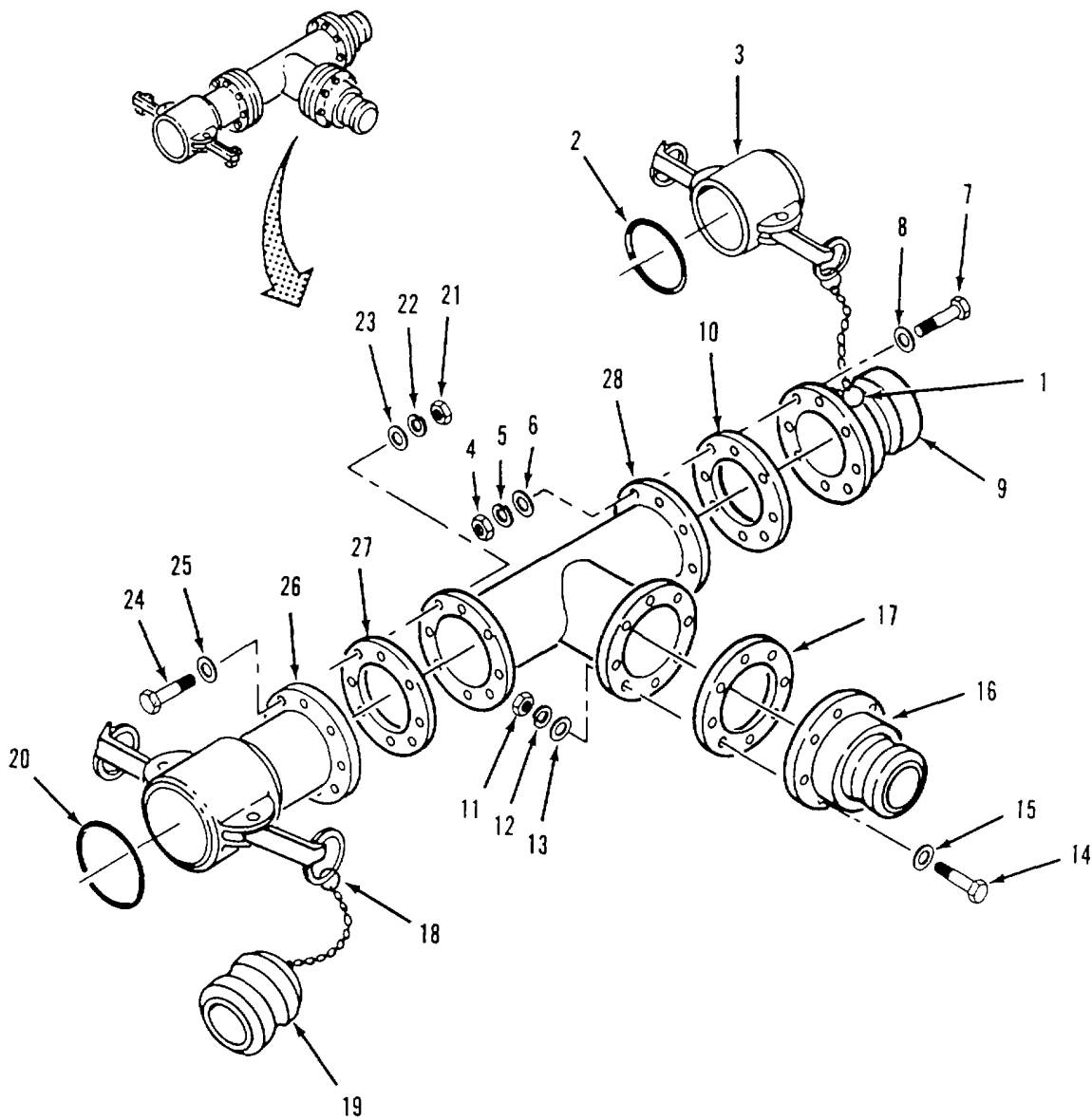

Figure 4-40. Tee Assembly (9115-Y1) Disassembly.

4-42. TEE ASSEMBLY (9115-Y1) REPAIR - cont.c. Inspection.

- (1) Inspect male couplings (9 and 16) for cracks.
- (2) Inspect female coupling (26) for cracks and damaged lock arms.
- (3) Inspect tee (28) for cracks and corrosion.

d. Repair. Replace defective components. Do not reuse sealing components.e. Assembly. Refer to figure 4-41.

- (1) Position gasket (27) and female coupling (26) on tee (28).
- (2) Install eight flat washers (25), screws (24), flat washers (23), lockwashers (22) and nuts (21).

NOTE

Ensure gasket is fully seated in groove of coupling.

- (3) Install gasket (20) in female coupling (26).
- (4) Connect plug (19) to female coupling (26) with ring (18).
- (5) Position gasket (17) and male coupling (16) on tee (28).
- (6) Install eight flat washers (15), screws (14), flat washers (13), lockwashers (12) and nuts (11).
- (7) Position gasket (10) and male coupling (9) on tee (28).
- (8) Install eight flat washers (8), screws (7), flat washers (6) lockwashers (5) and nuts (4).

NOTE

Ensure gasket is fully seated in groove of cap.

- (9) Install gasket (2) in cap (3)
- (10) Connect cap (3) to mate coupling (9) with ring (1)
- (11) Install tee assembly in water system (para 3-4a).
- (12) Startup water system (para 2-12c) and check tee assembly for leaks.

4-42. TEE ASSEMBLY (9115-Y1) REPAIR - cont.

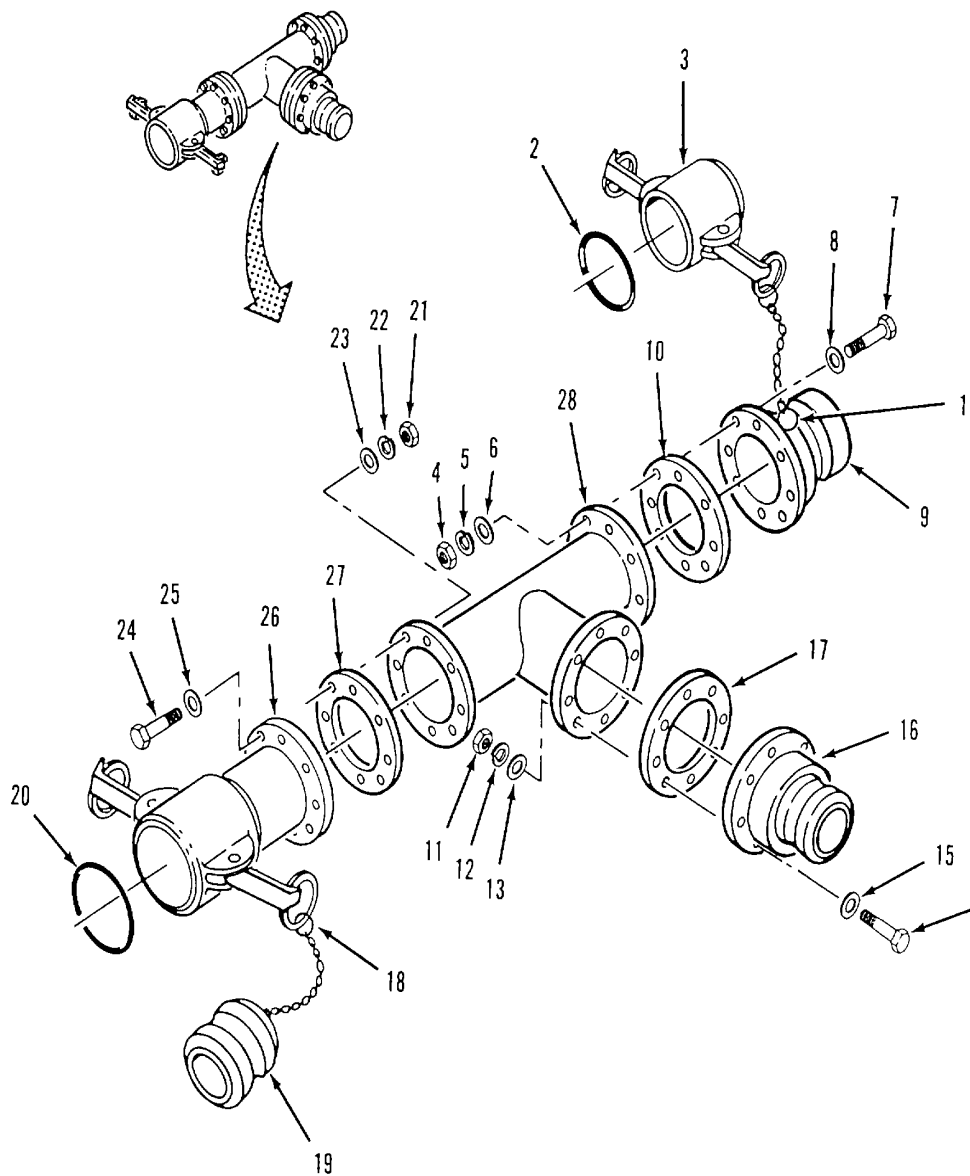

Figure 4-41. Tee Assembly (9115-Y1) Assembly.

4-43. WATER TANK CHEST REPAIR.

This task consists of:	a- Disassembly d. Repair	b. Cleaning e. Assembly	c. Inspection
------------------------	-----------------------------	----------------------------	---------------

INITIAL SETUP:

Tools: General Mechanics Tool Kit (Item 1, App B)	Wiping Rag (Item 2, App B)
Personnel Required Two	Gasket (roll) - 22036-9 (for top cover)
Material/Parts: Detergent, General Purpose (Item 1, App E)	Gasket (roll) - 22036-8 (for end panel)
	Gasket (roll) - 22002-17 (for side panel)

a. Disassembly. Refer to figure 4-42.

- (1) Unfasten eight latches (1) located on side panels (7 and 8).
- (2) Lift top cover (2) from tank chest.
- (3) Move four handles (3) on end panel (4) to OPEN position. Remove end panel from water tank chest.
- (4) Repeat step (3) for other end panel (5).
- (5) Unlock four locking pins (6) and lift side panel (7) from skid (10).
- (6) Repeat step (5) for other side panel (8).
- (7) Remove divider pan (9) from skid (10).

4-43. WATER TANK CHEST REPAIR - cont.

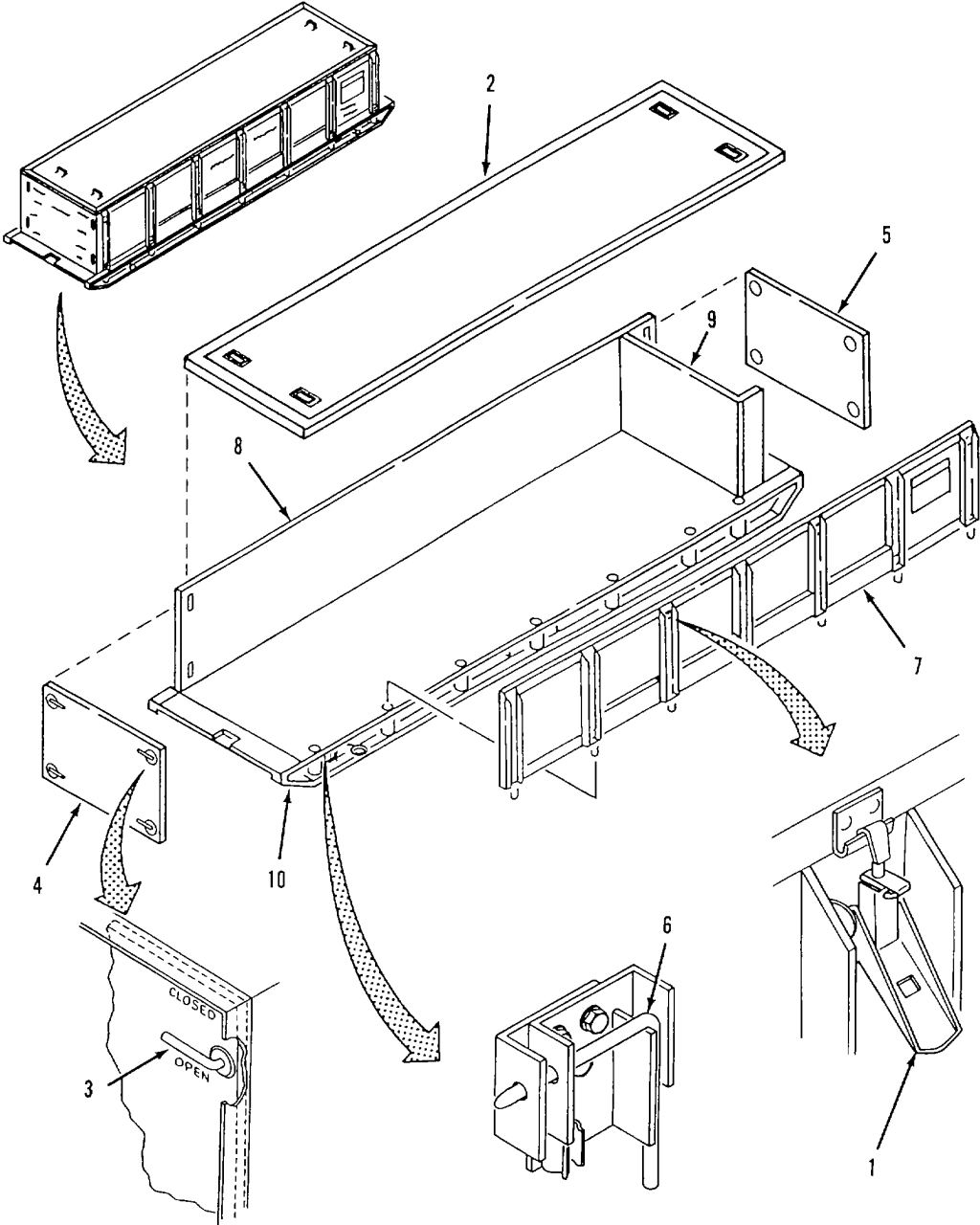

Figure 4-42. Water Tank Chest Repair.

4-43. WATER TANK CHEST REPAIR - contc. Repair.

Top Cover Repair. Refer to figure 4-43.

- (1) Peel damaged gasket material (1) from top cover (2).
- (2) Clean top cover (2) gasket mounting surface with detergent and clean water.
- (3) Wipe dry with wiping rag.

NOTE

Gasket material is supplied in rolls 34 feet long.

- (4) Cut two lengths of gasket material (1) 13-½ feet long.
- (5) Cut two lengths of gasket material (1) 3-½ feet long.
- (6) Peel backing from gasket material (1) and press in place on top cover (2).
- (7) Replace top cover if damaged beyond repair.

4-43. WATER TANK CHEST REPAIR - cont.

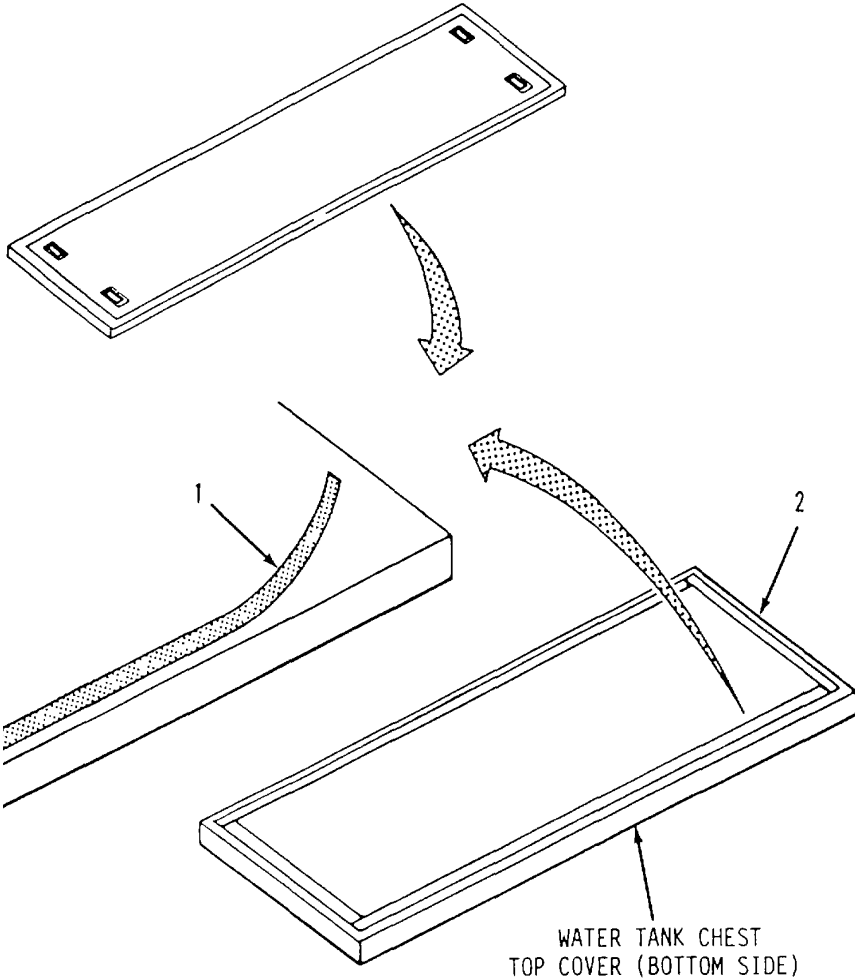

Figure 4-43. Top Cover Repair.

4-43. WATER TANK CHEST REPAIR - cont.

End Panel Repair. Refer to figure 4-44.

- (1) Gasket replacement.
 - (a) Peel damaged gasket material (1) from both sides of end panel (5).
 - (b) Clean end panel (5) gasket mounting surface with detergent and clean water.
 - (c) Wipe dry with wiping rag.

NOTE

Gasket material is supplied in rolls. Cut gasket to length as required.

- (d) Peel backing from gasket material (1) and press in place on end panel (5).
- (2) Handle replacement.
 - (a) Remove pin (2) from handle (4).
 - (b) Remove handle (4) and flat washer (3) from end panel (5).
 - (c) Position washer (3) and handle (4) in end panel (5).
 - (d) Insert pin (2) into opening in handle (4).
- (3) Replace end panel if cracked or badly damaged.

4-43. WATER TANK CHEST REPAIR- cont.

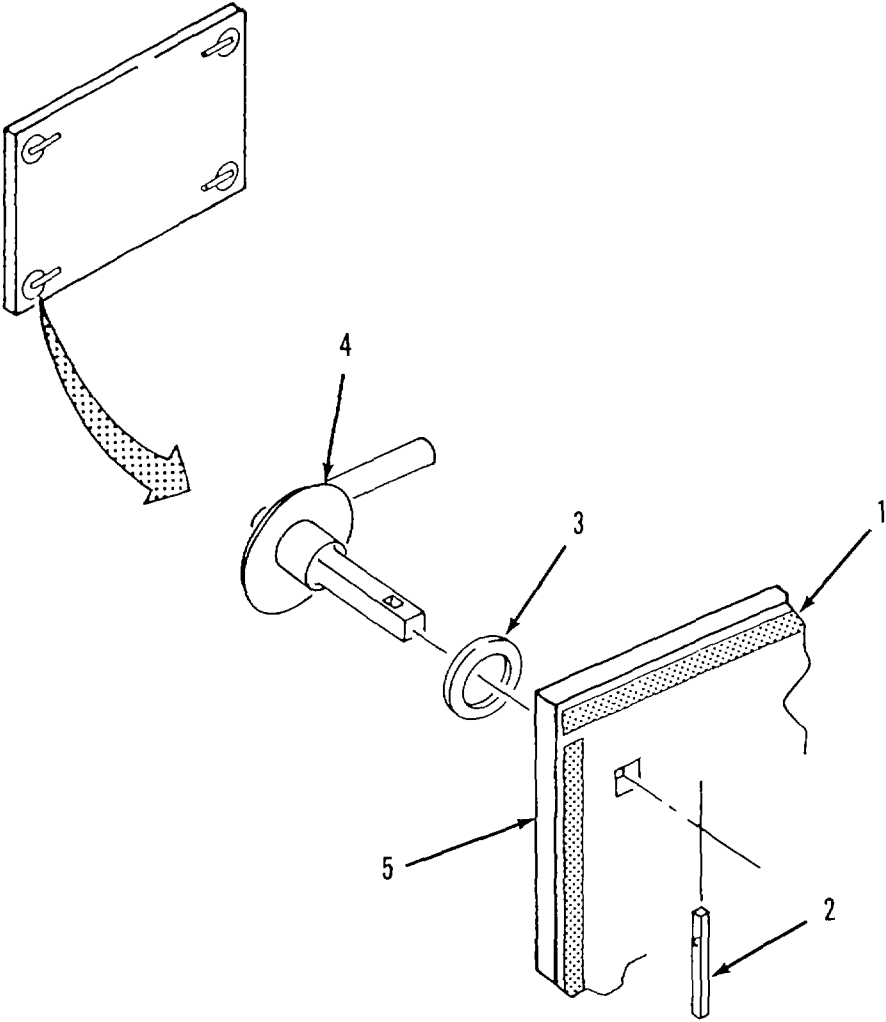

Figure 4-44. End Panel Repair.

4-43. WATER TANK CHEST REPAIR- cont.

Side Panel Repair. Refer to figure 4-45.

- (1) Peel damaged gasket material (1) from bottom edge of side panel (2).
- (2) Clean side panel (2) gasket mounting surface with detergent and clean water.
- (3) Wipe dry with wiping rag.

NOTE

Gasket material is supplied in rolls Cut gasket to length as required.

- (4) Peel backing from gasket material (1) and press in place on side panel (2).
- (5) Replace side panel if damaged beyond repair.

4-43. WATER TANK CHEST REPAIR- cont.

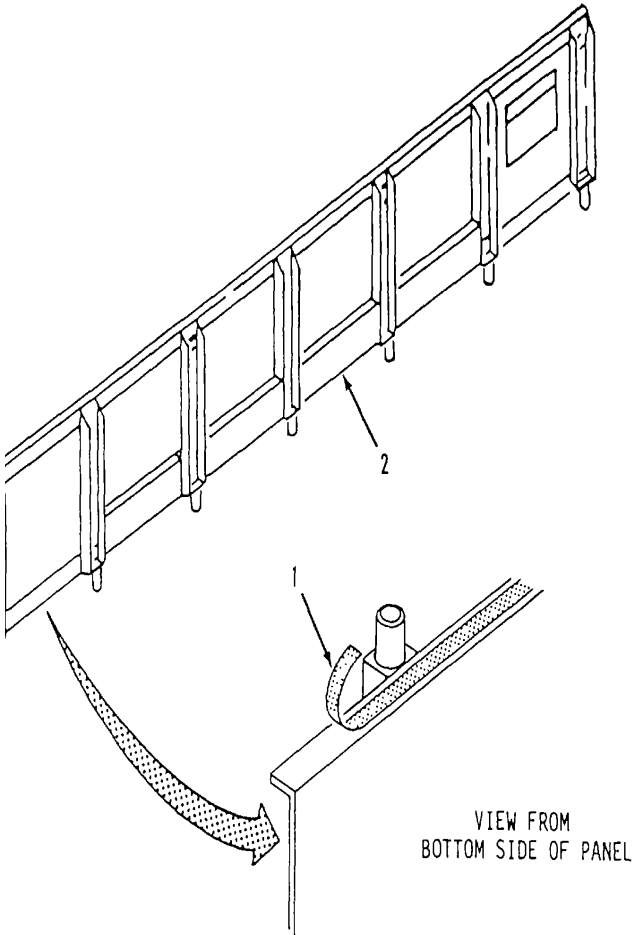

Figure 4-45. Side Panel Repair.

4-43. WATER TANK CHEST REPAIR- cont.

Skid Repair. Refer to figure 4-46.

- (1) Hoisting ring replacement.
- (a) Unscrew hoisting ring (1) from skid (10).
 - (b) Screw replacement hoisting ring (1) into skid (10).
- (2) Locking pin replacement.
- (a) Remove three nuts (2), lockwashers (3), flat washer (4), screw (5) and flat washer (6) from skid (10).
 - (b) Separate outer latch bracket (7) and inner latch bracket (9) from skid (10).
 - (c) Remove locking pin (8) from inner latch bracket (7).
 - (d) Position replacement locking pin (8) in inner latch bracket (7).
 - (e) Position inner latch bracket (7) and outer latch bracket (9) on skid (10).
 - (f) Install three flat washers (6), screws (5), flat washers (4), lockwashers (3) and nuts (2).
- (3) Replace skid if damaged beyond repair.

d. Assembly. Refer to figure 4-42.

- (1) Position side panel (7) on skid (10). lock four locking pins (6).
- (2) Repeat step (1) for other side panel (8).
- (3) Position end panel (4 and 5) between side panel (7 and 8). Turn four handles (3) to CLOSE position on both end panels.
- (4) Position divider pan (9) on skid (10).
- (5) Lower top cover (2) onto water chest. Fasten eight latches (1).

4-43. WATER TANK CHEST REPAIR-cont.

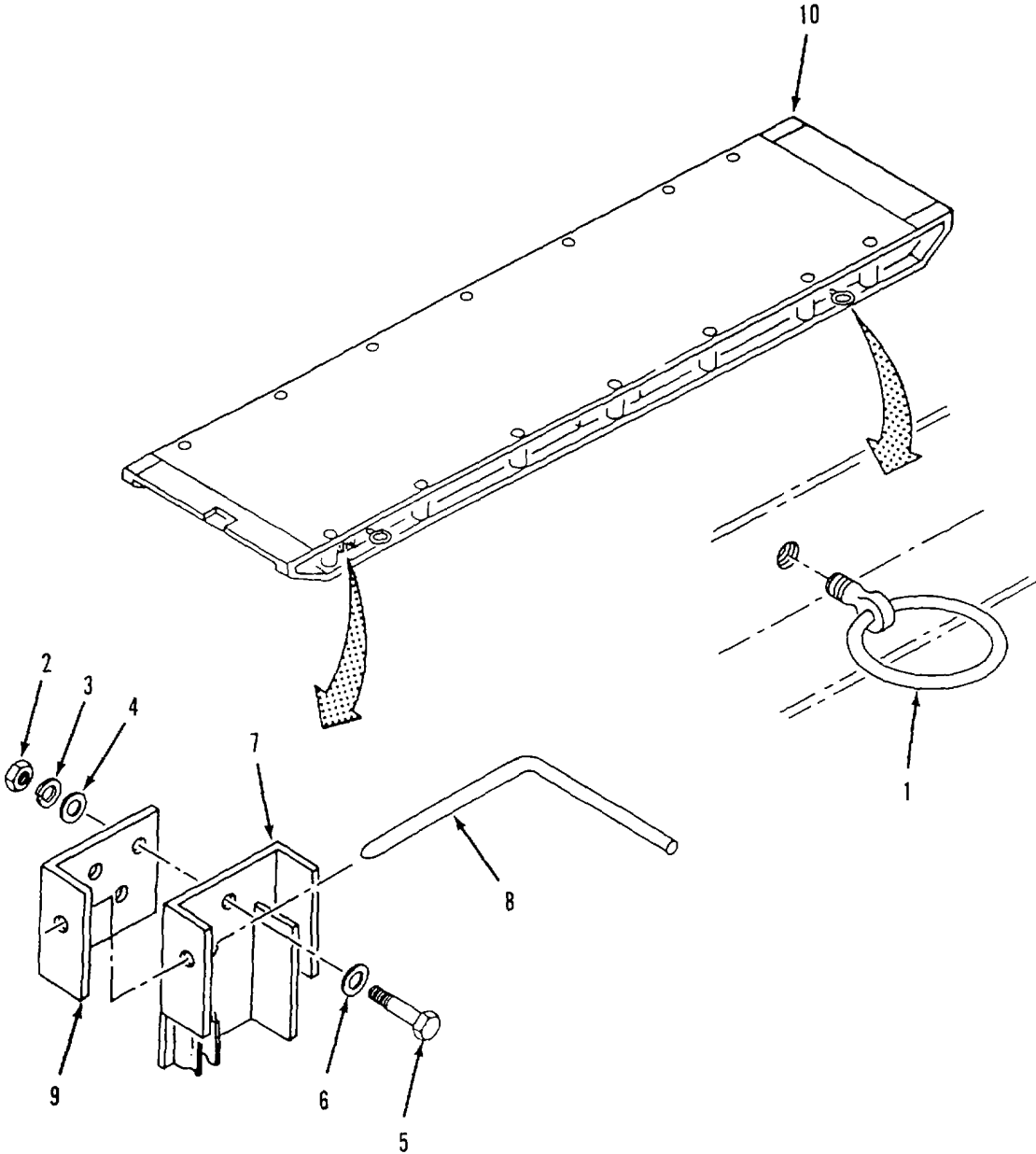

Figure 4-46. Skid Repair.

Section V. PREPARATION FOR STORAGE OR SHIPMENT**4-44. SECURITY PROCEDURES.**

Refer to AR 190-11 or AR 190-13.

4-45. ADMINISTRATIVE STORAGE.

- a. Placement of equipment in administrative storage should be for short periods of time when a shortage of maintenance effort exists. Items should be mission ready within 24 hours or within the time factors as determined by the directing authority. During the shortage period, appropriate maintenance records will be kept
- b. Before placing equipment in administrative storage, current maintenance services and equipment serviceable criteria (ESC) evaluations should be completed, shortcomings and deficiencies should be corrected, and all modification work orders (MWOs) should be applied.
- c. Storage Site Selection. Inside storage is preferred for items selected for administrative storage. If inside storage is not available, keep tricons away from corrosive materials, such as saltwater spray.

CHAPTER 5

DIRECT SUPPORT MAINTENANCE INSTRUCTIONS

Direct Support Maintenance Procedure..... 5-1
 5-1 Introduction..... 5-1
 5-2 Water Tank Chest Repair 5-1

DIRECT SUPPORT MAINTENANCE PROCEDURE

5-1. INTRODUCTION.

This Chapter contains instructions for performing Direct Support level maintenance on the 800K Water Storage and Distribution System.

5-2. WATER TANK CHEST REPAIR.

This task consists of: Repair

INITIAL SET-UP:

Tools:

Welding Shop (Appendix B, Sec III Item 3)

References:

TM 43-0139 Painting Instructions for Army Materiel.

Repair.

- a. Inspect for cracks, broken latches and handles, and broken frame parts.
- b. Weld water tank chest as required.
- c. Paint water tank chest in accordance with TM 43-0139.

APPENDIX A

REFERENCES

A-1. SCOPE

This appendix lists all forms, Field manuals, technical manuals, and miscellaneous publications referenced in this manual.

A-2. FORMS

Equipment Control Record	DA Form 2408-9
Equipment Inspection and Maintenance Worksheet	DA Form 2404
Quality Deficiency Report.....	SF 368
Recommended Changes to Publications and Blank Forms.....	DA Form 2028
Report of Discrepancy.....	SF 364

A-3. FIELD MANUALS

First Aid for Soldiers.....	FM 4-25.11
-----------------------------	------------

A-4. MISCELLANEOUS

Consolidated Index of Army Publications and Blank Forms	DA PAM 25-30
Destruction of Army Materiel to Prevent Enemy Use	TM 750-224-3
Painting Instructions for Army Materiel	TM 43-0139
The Army Maintenance Management System (TAMMS)	DA PAM 750-8
Operator's, Unit and Direct Support Maintenance Manual (Including Repair Parts and Special Tools last) for TRICON Multipurpose Equipment Shelter.....	TM 55-8145-200-13&P

APPENDIX B

MAINTENANCE ALLOCATION CHART (MAC)

Section I. INTRODUCTION

B-1. The Army Maintenance System MAC

- a. This introduction (Section I) provides a general explanation of all maintenance and repair functions authorized at the two maintenance levels under the Two-Level Maintenance System concept.
- b. The MAC (immediately following, Section II) designates overall authority and responsibility for the performance of maintenance functions on the identified end item or component. The application of the maintenance functions to the end item or component shall be consistent with the capacities and capabilities of the designated maintenance levels, which are shown on the MAC in column (4) as:

Field – includes two sub columns, Unit (C (operator/crew) and O (unit)) and Direct Support (F) maintenance.

Sustainment – includes two sub columns, General Support (H) and Depot (D).

- c. Section III, Tools and Test Equipment, lists the tools and test equipment (both special tools and common tool sets) required for each maintenance function as referenced from the MAC.
- d. Section IV, Remarks, contains supplemental instructions and explanatory notes for a particular maintenance function.

B-2. Maintenance Functions

Maintenance functions are limited to and defined as follows:

- a. **Inspect.** To determine the serviceability of an item by comparing its physical, mechanical and/or electrical characteristics with established standards through examination (e.g., by sight, sound or feel).
- b. **Test.** To verify serviceability by measuring the mechanical, pneumatic, hydraulic or electrical characteristics of an item and comparing those characteristics with prescribed standards on a scheduled basis, i.e., load testing of lift devices and hydrostatic testing of pressure hoses.
- c. **Service.** Operations required periodically to keep an item in proper operating condition; e.g., to clean (includes decontaminate, when required), to preserve, to drain, to paint or to replenish fuel, lubricants, chemical fluids or gases. The following are examples of service functions:
 - (1) **Unpack.** To remove from packing box for service or when required for the performance of maintenance operations.
 - (2) **Repack.** To return item to packing box after service and other maintenance operations.
 - (3) **Clean.** To rid the item of contamination.
 - (4) **Touch up.** To spot paint scratched or blistered surfaces.
 - (5) **Mark.** To restore obliterated identification.

- d. Adjust. To maintain or regulate, within prescribed limits, by bringing into proper position, or by setting the operating characteristics to specified parameters.
- e. Align. To adjust specified variable elements of an item to bring about optimum or desired performance.
- f. Calibrate. To determine and cause corrections to be made or to be adjusted on instruments of test, measuring and diagnostic equipment used in precision measurement. Consists of comparisons of two instruments, one of which is a certified standard of known accuracy, to detect and adjust any discrepancy in the accuracy of the instrument being compared.
- g. Remove/Install. To remove and install the same item when required to perform service or other maintenance functions. Install may be the act of emplacing, seating or fixing into position a spare, repair part or module (component or assembly) in a manner to allow the proper functioning of equipment or a system.
- h. Replace. To remove an unserviceable item and install a serviceable counterpart in its place. "Replace" is authorized by the MAC and the assigned maintenance level is shown as the third position code of the Source, Maintenance and Recoverability (SMR) code.
- i. Repair. The application of maintenance services, including fault location/troubleshooting, removal/installation, disassembly/assembly procedures and maintenance actions to identify troubles and restore serviceability to an item by correcting specific damage, faults, malfunction or failure in a part, subassembly, module (component or assembly), end item or system.

NOTE

The following definitions are applicable to the "repair" maintenance function:

- (1) Services. Inspect, test, service, adjust, align, calibrate and/or replace.
 - (2) Fault location/troubleshooting. The process of investigating and detecting the cause of equipment malfunctioning; the act of isolating a fault within a system or Unit Under Test (UUT).
 - (3) Disassembly/assembly. The step-by-step breakdown (taking apart) of a spare/functional group coded item to the level of its least component, that is assigned an SMR code for the level of maintenance under consideration (i.e., identified as maintenance significant).
 - (4) Actions. Welding, grinding, riveting, straightening, facing, machining and/or resurfacing.
- j. Overhaul. The maintenance effort (service/action) prescribed to restore an item to a completely serviceable/operational condition as required by maintenance standards in appropriate technical publications. Overhaul is normally the highest degree of maintenance performed by the Army. Overhaul does not normally return an item to like new condition.
 - k. Rebuild. Consists of those services/actions necessary for the restoration of unserviceable equipment to a like new condition in accordance with original manufacturing standards. Rebuild is the highest degree of materiel maintenance applied to Army equipment. The rebuild operation includes the act of returning to zero those age measurements (e.g., hours/miles) considered in classifying Army equipment/components.

B-3. Explanation of Columns in the MAC, Section II

- a. Column (1) Group Number. Column (1) lists Functional Group Code (FGC) numbers, the purpose of which is to identify maintenance significant components, assemblies, subassemblies and modules with the Next Higher Assembly (NHA).
- b. Column (2) Component/Assembly. Column (2) contains the item names of components, assemblies, subassemblies and modules for which maintenance is authorized.
- c. Column (3) Maintenance Function. Column (3) lists the functions to be performed on the item listed in column (2). (For a detailed explanation of these functions refer to "Maintenance Functions" previously defined).
- d. Column (4) Maintenance Level. Column (4) specifies each level of maintenance authorized to perform each function listed in column (3), by indicating work time required (expressed as man-hours in whole hours or decimals) in the appropriate sub column. This work time figure represents the active time required to perform that maintenance function at the indicated level of maintenance. If the number or complexity of the tasks within the listed maintenance function varies at different maintenance levels, appropriate work time figures are to be shown for each level. The work time figure represents the average time required to restore an item (assembly, subassembly, component, module, end item or system) to a serviceable condition under typical field operating conditions. This time includes preparation time (including any necessary disassembly/assembly time), troubleshooting/fault location time and quality assurance time in addition to the time required to perform the specific tasks identified for the maintenance functions authorized in the MAC. The symbol designations for the various maintenance levels are as follows:

Field:

- C Operator or Crew maintenance
- O Unit maintenance
- F Direct Support maintenance

Sustainment:

- H General Support maintenance
- D Depot maintenance

- e. Column (5) Tools and Test Equipment Reference Code. Column (5) specifies, by code, those common tool sets (not individual tools), common Test, Measurement and Diagnostic Equipment (TMDE) and special tools, special TMDE and special support equipment required to perform the designated function. Codes are keyed to the entries in the tools and test equipment table in Section III.
- f. Column (6) Remarks Code. When applicable, this column contains a letter code, in alphabetical order, which is keyed to the remarks table entries in Section IV.

B-4. Explanation of Columns in the Tools and Test Equipment Requirements, Section III

- a. Column (1) Tool or Test Equipment Reference Code. The tool or test equipment reference code correlates with a code used in column (5) of the MAC.
- b. Column (2) Maintenance Level. The lowest level of maintenance authorized to use the tool or test equipment.
- c. Column (3) Nomenclature. Name or identification of the tool or test equipment.
- d. Column (4) National Stock Number (NSN). The NSN of the tool or test equipment.
- e. Column (5) Tool Number. The manufacturer's part number.

B-5. Explanation of Columns in the Remarks, Section IV

- a. Column (1) Remarks Code. The code recorded in column (6) of the MAC.
- b. Column (2) Remarks. This column lists information pertinent to the maintenance function being performed as indicated in the MAC.

**SECTION II. MAINTENANCE ALLOCATION CHART
FOR
800K GAL. WATER STORAGE & DISTRIBUTION SYSTEM (WSDS)**

(1) Group Number	(2) Component/Assembly	(3) Maintenance Function	(4) Maintenance Level					(5) Tools and Test Equipment Ref Code	(6) Remarks Code
			Field		Sustainment				
			Unit		DS	GS	Depot		
			C	O	F	H	D		
00	800,000 Gallon Water Storage and Distribution System								
01	Bag Filler Connection Kits								
0101	Discharge Hose, 1 ½ inch x 25 ft	Inspect Replace Repair	0.1 0.2	1.0				1	
0102	Gate Valve Assembly, 2 inch (9111-Y)	Inspect Replace Repair	0.1 0.2	1.5				1,2	
0103	Discharge Hose, 2 in x 20 ft	Inspect Replace Repair	0.1 0.2	1.0				1	
0104	Tee Assembly (9117-Y1)	Inspect Replace Repair	0.1 0.2	1.0				1,2	
0105	Discharge Hose, 4 in x 20ft	Inspect Replace Repair	0.1 0.2	1.0				1	
0106	Hose and Nozzle Kit								
010601	Distribution Nozzle, 1 inch	Inspect Replace Repair	0.1 0.2	0.5				1,2	
010602	Discharge Hose, 1 in x 10ft	Inspect Replace Repair	0.1 0.2	1.0				1,2	
010603	Water Pressure Regulator Assembly	Inspect Replace Repair Adjust	0.1 0.2	1.0 0.5				1,2	
010604	Nozzle Stand Assembly	Inspect Replace Repair	0.1 0.2	1.5				1	

**SECTION II. MAINTENANCE ALLOCATION CHART – cont'd
FOR
800K GAL. WATER STORAGE & DISTRIBUTION SYSTEM (WSDS)**

(1) Group Number	(2) Component/Assembly	(3) Maintenance Function	(4) Maintenance Level					(5) Tools and Test Equipment Ref Code	(6) Remarks Code
			Field			Sustainment			
			Unit		DS	GS	Depot		
			C	O	F	H	D		
02	Hose Nozzle Connection Kit								
0201	Distribution Nozzle 1 ½ inch	Inspect Replace Repair	0.1 0.2	0.5				1,2	
0202	Discharge Hose, 1 ½ in x 25 ft	Inspect Replace Repair	0.1 0.2	1.0				1,2	
0203	Discharge Hose, 2 in x 20 ft	Inspect Replace Repair	0.1 0.2	1.0				1,2	
0204	Gate Valve, 2 inch	Inspect Replace Repair	0.1 0.2	1.5				1,2	
0205	Tee Assembly (9117-Y and Y1)	Inspect Replace Repair	0.1 0.2	1.0				1	
0206	Discharge Hose, 4 in x 20 ft	Inspect Replace Repair	0.1 0.2	1.0				1,2	
0207	Nozzle Stand Assembly	Inspect Replace Repair	0.1 0.2	1.5				1	
03	2 inch Hose Connection Kit								
0301	Discharge Hose, 2 in x 20 ft	Inspect Replace Repair	0.1 0.2	1.0				1,2	
0302	Gate Valve, 2 inch	Inspect Replace Repair	0.1 0.2	1.5				1,2	
0303	Tee Assembly 4 inch (9117-Y1)	Inspect Replace Repair	0.1 0.2	1.0				1	
0304	Discharge Hose, 4 in x 20 ft	Inspect Replace Repair	0.1 0.2	1.0				1,2	

**SECTION II. MAINTENANCE ALLOCATION CHART- cont'd
FOR
800K GAL. WATER STORAGE & DISTRIBUTION SYSTEM (WSDS)**

(1) Group Number	(2) Component/Assembly	(3) Maintenance Function	(4) Maintenance Level					(5) Tools and Test Equipment Ref Code	(6) Remarks Code
			Field			Sustainment			
			Unit		DS	GS	Depot		
			C	O	F	H	D		
0305	Nozzle Stand	Inspect Replace Repair	0.1 0.2	1.5				1	
04	Hose Connection Kit, 4 inch								
0401	Butterfly Valve Assembly, 4 inch (9133-Y2)	Inspect Replace Repair	0.1 0.2	1.5				1	
0402	Discharge Hose, 4 in x 20 ft	Inspect Replace Repair	0.1 0.2	1.0				1	
0403	Quick Acting Valve Assembly, 4 inch (9133-Y)	Inspect Replace Repair	0.1 0.2	1.5				1	F
0405	Tee Assembly (9117-Y1)	Inspect Replace Repair	0.1 0.2	0.5				1	F
0406	Nozzle Stand	Inspect Replace Repair	0.1 0.2	1.5				1	
0407	Tee and Gate Valve Assembly (9133-Y-1)	Inspect Replace Repair	0.1 0.2	2.0				1,2	F
0408	Suction Hose 4 in x 20 ft	Inspect Replace Repair	0.1 0.2	1.0				1,2	F
05	Hypochlorination Unit								A
06	350 GPM Pump Connection Kit								
0601	Tee Assemblies, 4 inch (9112-Y1, Y2, Y3, Y4)	Inspect Replace Repair	0.1 0.2	1.0				1	
0605	Suction Hoses, 4 in x 20 ft	Inspect Replace Repair	0.1 0.2	2.0				1	

**SECTION II. MAINTENANCE ALLOCATION CHART- cont'd
FOR
800K GAL. WATER STORAGE & DISTRIBUTION SYSTEM (WSDS)**

(1) Group Number	(2) Component/Assembly	(3) Maintenance Function	(4) Maintenance Level					(5) Tools and Test Equipment Ref Code	(6) Remarks Code
			Field			Sustainment			
			Unit		DS	GS	Depot		
			C	O	F	H	D		
0606	Gate Valve Assemblies, 4 inch	Inspect	0.1					1,2	
		Replace	0.2						
		Repair		1.5					
0607	Discharge Hoses, 4 in x 20 ft	Inspect	0.1					1,2	
		Replace	0.2						
		Repair		1.0					
0608	Water Meter Assembly	Inspect	0.1					1,2	
		Replace	0.2						
		Repair		1.0					
07	Pumping Assembly, 350 GPM							A	
08	125 GPM Pump Connection Kit								
0801	Discharge Hoses, 2 in x 20 ft	Inspect	0.1					1,2	
		Replace	0.2						
		Repair		1.0					
0802	Gate Valve Assembly 2 inch	Inspect	0.1					1,2	
		Replace	0.2						
		Repair		1.5					
0803	Check Valve, 2 inch	Inspect	0.1					1,2	
		Replace	0.2						
		Repair		1.0					
0804	Suction Hose, 2 in x 20 ft.	Inspect	0.1					1,2	
		Replace	0.2						
		Repair		1.0					
09	Pump Assembly, 125 GPM							A	
10	Dual Tank Connection Kit								
1001	Discharge Hoses, 4 in x 10 ft and 4 in x 20 ft	Inspect	0.1					1,2	
		Replace	0.2						
		Repair		1.0					
1002	Tee and Gate Valve Assemblies, 4 inch (9114-Y1, Y2, Y5, Y6)	Inspect	0.1					1,2	
		Replace	0.2						
		Repair		2.0					

**SECTION II. MAINTENANCE ALLOCATION CHART- cont'd
FOR
800K GAL. WATER STORAGE & DISTRIBUTION SYSTEM (WSDS)**

(1) Group Number	(2) Component/Assembly	(3) Maintenance Function	(4) Maintenance Level					(5) Tools and Test Equipment Ref Code	(6) Remarks Code
			Field		Sustainment				
			Unit		DS	GS	Depot		
			C	O	F	H	D		
1003	Suction Hoses, 4 in x 10 ft and 4 in x 20 ft	Inspect Replace Repair	0.1 0.2	1.0				1,2	
11	Interconnection Kit, 4 inch Discharge								
1101	Discharge Hose, 4 in x 20 ft	Inspect Replace Repair	0.1 0.3	1.0				1,2	
1102	Tee and Gate Valve Assemblies (9115-Y, Y1)		0.1 0.3	0.7				1,2	
12	Tank, Fabric, Collapsible, 50,000 Gallon								A
13	Accessory Kit	Replace	0.2						B
14	Water Tank Chest	Inspect Replace Repair	0.1 0.3	1.0	3.0			1,2,3	D,E
15	Triple Container								C

**SECTION III. TOOLS AND TEST EQUIPMENT
FOR
800K GAL. WATER STORAGE & DISTRIBUTION SYSTEM (WSDS)**

Tool or Test Equipment Ref. Code	Maintenance Level	Nomenclature	National Stock Number (NSN)	Tool Number
1	O	Tool Kit, General Mechanics:	5180-00-177-7033	SC 5180-90-CL-N26
2	O	Shop Set, Automotive Vehicle	4910-00-754-0654	SC 4910-95-CL-A74
3	F	Welding Shop, Trailer Mounted	3431-01-090-1231	SC 3431-95-CL-A04

**SECTION IV. REMARKS
FOR
800K GAL. WATER STORAGE & DISTRIBUTION SYSTEM (WSDS)**

Remarks Code	Remarks
A	Refer to applicable Technical Manual.
B	Repair limited to replacement.
C	Refer to TM 55-8145-200-13&P.
D	Unit level repair limited to replacement of latches, hinges, gaskets and spot painting.
E	Direct Support repair is limited to welding of skid.
F	Model 800KWSDS. Group 407 replaces groups 403 and 405. Group 408 is added hose assembly.

APPENDIX C

COMPONENTS OF END ITEM AND BASIC ISSUE ITEMS LIST

Section I. INTRODUCTION

C-1. SCOPE.

This appendix lists components of end item and basic issue items for the Model WSDS810 and Model 800KWSDS 800K Water Storage and Distribution Systems to help you inventory items required for safe and efficient operation.

C-2. GENERAL.

The Components of End Item and Basic Issue Items List are divided into the following sections:

- a. Section II. Components of End Item. This listing is for informational purposes only, and is not authority to requisition replacements. These items are part of the end item, but are removed and separately packaged for transportation or shipment. As part of the end item, these items must be with the end item whenever it is issued or transferred between property accounts. Illustrations are furnished to assist you in identifying the items.
- b. Section III. Basic Issue Items. These are the minimum essential items required to place the 800K Water Storage and Distribution System in operation, to operate it, and to perform emergency repairs. Although shipped separately packaged, BII must be with the distribution system during operation and whenever it is transferred between property accounts. The illustrations will assist you with hard-to-identify items. This manual is your authority to request/requisition replacement BII, based on TOE/MTOE authorization of the end item.

C-3. EXPLANATION OF COLUMNS.

The following provides an explanation of columns found in the tabular listing:

- a. Column (1) - Illustration Number (Illus Number). This column indicates the number of the illustration in which the item is shown..
- b. Column (2) - National Stock Number. Indicates the national stock number assigned to the item and will be used for requisitioning purposes.
- c. Column (3) - Description and Usable On Code. Indicated the Federal item name and, if required, a minimum description to identify and locate the item. The last line for each item indicates the CAGE (in parentheses) followed by a part number. If the item you need is not the same for different models of the equipment, a usable on code will appear on the right side of the description column on the same line as the part number. These codes are identified below:

<u>CODE</u>	<u>USED ON</u>
FFR	Model WSDS810
FKG	Model 800KWSDS
- d. Column (4) - Unit of Measure (U/M). Indicates the measure used in performing the actual operational/maintenance function. This measure is expressed by a two-character alphabetical abbreviation (e.g., ea., in., pr.).
- e. Column (5) - Quantity Required (Qty Rqd). Indicates the quantity of the item authorized to be used with/on the equipment.

Section II. COMPONENTS OF END ITEM

(1) ILLUS NUMBER	(2) NATIONAL STOCK NUMBER	(3) DESCRIPTION CAGE and Part Number	(4) U/M	(5) QTY RQD
1	4610-01-120-7525	ACCESSORY KIT, 20K AND 50K GALLON TANKS (97403) 13225E9125 CONSISTING OF THE FOLLOWING COMPONENTS:	EA	1
	4730-00-935-1613	NIPPLE, QD, 4 IN (96906) MS39352-19	EA	7
	4730-01-009-1735	NIPPLE, QD, MXM, 2 IN. (96906) MS39352-9	EA	2
	4730-01-190-5538	NIPPLE, QD, MXM, 2 IN. X 4 IN. (96906) MS39352-13	EA	1
	4730-01-185-9496	NIPPLE, QD, MXM, 1-½ IN. X 4 IN. (96906) MS39352-7	EA	1
	4930-00-541-6092	NIPPLE, QD, MXM, 1-½ IN. X 2 IN. (96906) MS39352-3	EA	1
	4730-01-182-1390	ADAPTER, PIPE TO HOSE, 2 IN. X 2 IN. MXF (81349) MIL-C-52404	EA	1
	5120-00-278-9925	CLAMPING TOOL (81349) GGG-C-00413	EA	1
	4730-00-555-1660	COUPLING HALF, QD, MALE, 4 IN. (96906) MS27020-17	EA	2
	4730-00-840-0797	COUPLING HALF, QD, MALE, 4 IN. (96906) MS27022-17	EA FFR EA FKG	2 4
	4730-00-840-5347	COUPLING HALF, QD, MALE, FLANGED, 4 IN. (96906) MS27023-17	EA	14
	4730-00-840-5348	COUPLING HALF, QD, FEMALE, FLANGED, 4 IN. (96906) MS27027-17	EA	14
	4730-00-983-6789	COUPLING HALF, QD, FEMALE, FLANGED, 6 IN. (96906) MS27027-19	EA	2
	4730-00-649-9100	CAP, QD, DUST CAP, 2 IN. (96906) MS27028- 11	EA	12
	4730-00-640-6156	CAP, QD, DUST CAP, 4 IN. (96906) MS27028-17	EA	29

Section II. COMPONENTS OF END ITEM

(1) ILLUS NUMBER	(2) NATIONAL STOCK NUMBER	(3) DESCRIPTION CAGE and Part Number	Usable on Code	(4) U/M	(5) QTY RQD
	4730-00-915-5127	PLUG, QD, 2 IN. (96906) MS27029-11		EA	12
	4730-00-640-6188	PLUG, QD, 4 IN. (96906) MS27029-17		EA	43
	4730-00-649-9103	COUPLING HALF, QD, FEMALE, 2 IN. (96906) MS27024-11		EA	2
	4730-00-088-9286	COUPLING HALF, QD, FEMALE, 4 IN. (96906) MS27024-17		EA	7
	4730-00-088-9285	COUPLING HALF, QD, FEMALE, 2 IN. (96906) MS27026-11		EA	2
	4730-00-980-9411	COUPLING HALF, QD, FEMALE, 1-½ IN. (96906) MS27024-9		EA	1
	5430-00-823-5316	PLUG, QD, 1-½ IN. (96906) MS27029-9		EA	4
	4730-00-869-5246	CAP, QD, 1-½ IN. (96906) MS27028-9		EA	4
	4730-00-649-9118	COUPLING, HALF, QD, FEMALE, 4 IN. (96906) MS27026-17	FFR FKG	EA EA EA	7 9 2
	4730-01-187-8051	ADAPTER, FLANGE, 6 IN. (79154) 45A		EA	2
	5330-01-141-1864	GASKET, FLANGE, 4 IN. (97403) 13220E1069-1		EA	46
	5330-01-167-6542	GASKET, FLANGE, 2 IN. (97403) 13220E1069-2		EA	6
	5330-01-173-8301	GASKET, FLANGE, 6 IN. (97403) 13220E1069-3		EA	6
	5330-00-899-4509	GASKET, QD, 4 IN. (96906) MS27030-9		EA	24
	5330-00-612-2414	GASKET, QD, 2 IN. (96906) MS27030-6		EA	24
	5330-00-360-0595	GASKET, QD, 1-½ IN. (96906) MS27030-5		EA	4

Section II. COMPONENTS OF END ITEM

(1) ILLUS NUMBER	(2) NATIONAL STOCK NUMBER	(3) DESCRIPTION CAGE and Part Number	(4) Usable on U/M Code	(5) QTY RQD
	5330-00-412-9780	GASKET, QD, 6 IN. (96906) MS27030-10	EA	6
	3835-00-967-9029	GUARD, ROAD CROSSING (81349) MIL-G-52346	EA	1
	4720-01-138-8986	HOSE ASSY, DISCHARGE, 2 IN. X 20 FT. (97403) 13225E9136-2	EA	31
	4720-01-163-4684	HOSE ASSY, SUCTION, 2IN. X 20FT. (97403) 13225E9135-2	EA	8
	4920-01-163-5089	HOSE ASSY, SUCTION, 4 IN. X 20 FT. (97403) 13225E9135-4	EA	34
	4720-01-140-6288	HOSE ASSY, DISCHARGE, 4 IN. X 20 FT (97403) 13225E9136-4	EA	58
	4720-01-163-5088	HOSE ASSY, DISCHARGE, 2 IN. X 10 FT. (97403) 13225E9136-1	EA	8
	4720-01-163-4683	HOSE ASSY, SUCTION, 2 IN. X 10 FT. (97403)13225E9135-1	EA	4
	4720-01-163-4685	HOSE ASSY, SUCTION, 4 IN. X 10 FT. (97403) 13225E9135-3	EA	22
	4720-01-163-4682	HOSE ASSY, DISCHARGE, 4 IN. X 10 FT. (97403) 13225E9136-3	EA	22
	4720-01-174-8173	HOSE ASSY, DISCHARGE, 1-½ IN. X 25 FT. (97403) 13225E9136-11	EA	4
	4720-01-NIIN	REPAIR KIT, HOSELINE (97403) 13225E9147	EA	1
	4730-01-182-2001	NIPPLE, HOSE, FEMALE, 3 IN. X 3 IN. (30659) 359-3	EA	1
	4730-01-182-2002	NIPPLE, HOSE, FEMALE, 4 IN. X 4 IN. (30659) 3594	EA	1
	4730-00-825-9705	NIPPLE, PIPE, FEMALE, 4 IN. X 6 IN. (81346) ASTM-B687	EA	1
	5310-00-732-0558	NUT, PLAIN, HEX (96906) MS51967-8	EA	188

Section II. COMPONENTS OF END ITEM

(1) ILLUS NUMBER	(2) NATIONAL STOCK NUMBER	(3) DESCRIPTION CAGE and Part Number	Usable On Code	(4) U/M	(5) QTY RQD
	4730-00-068-0393	REDUCER, QD, 4 IN. FEMALE X 6 IN. MALE (96906) MS49000-23		EA	6
	4730-01-079-8234	REDUCER, QD, 6 IN. FEMALE X 6 IN. MALE (96906) MS49000-21		EA	4
	4730-01-186-0819	REDUCER, 3 IN. EXT PIPE X 4 IN. MALE QD (96906) MS49001-13		EA	1
	4730-00-109-2513	REDUCER, QD, 4 IN. FEMALE X 3 IN. INT PIPE (96906) MS70097-3		EA	2
	4730-01-180-6879	REDUCER, 6 IN. X 4 IN. (79154) 52A		EA	2
	5365-00-926-5411	RING, SPLIT (97403) 13227E6160-7		EA	41
	5305-00-269-3215	SCREW, CAP (96906) MS90725-65		EA	188
	5340-00-244-7325	SEAL, STRAPPING, 1/2 IN. (70847) C254		BX	2
	5340-00-244-7327	SEAL, STRAPPING, 3/4 IN. (70847) C256		BX	2
	5340-00-245-9438	STRAPPING, 1/2 IN. (70847) C204		RL	2
	5340-00-245-9440	STRAPPING, 3/4 IN. (70847) C206		RL	2
	8030-00-889-3535	TAPE, ANTISEIZE (81349) MIL-T-27730		EA	10
	4730-00-840-5346	TEE, FLANGED, 4 IN. (97403)13216E8243		EA	4
	4820-01-159-0439	VALVE, GATE, 4 IN. (97403)13220E1071		EA	14
	4820-01-226-4636	VALVE, BALL, 4 IN. (92021) 4"-SP-A-20-S-2	FKG	EA	2
	4820-01-167-6550	VALVE, ELBOW, 2 IN. (97403)13219E0491		EA	2
	5310-00-080-6004	WASHER, FLAT (96906) MS27183-14		EA	376

Section II. COMPONENTS OF END ITEM

(1) ILLUS NUMBER	(2) NATIONAL STOCK NUMBER	(3) DESCRIPTION CAGE and Part Number	Usable On Code	(4) U/M	(5) QTY
	5310-00-637-9541	WASHER, LOCK SPRING (96906) MS35338-46		EA	188
	5120-01-327-7086	WRENCH, CHAIN (50893)92680		EA	1
	5120-00-277-1482	WRENCH, PIPE, 48 IN. (50893) 848		EA	1
2	2910-00-066-1235	ADAPTER ASSY, FUEL DRUM (97403) 13211E7541		EA	5
3	7240-00-222-3088	CAN, GAS, MILITARY, 5 GAL. (81349) MIL-C-1283		EA	16
4	5430-01-168-0589	CHEST, WATER TANK - 50K (90598) 22000-601		EA	16
5	4610-01-120-7528	CONNECTION KIT, BAG FILLER (97403)13225E9111 CONSISTING OF THE FOLLOWING COMPONENTS:		EA	1
	4270-01-174-8173	HOSE ASSY, DISCHARGE, QD, 1-1/2 IN. X 25 FT. (97403) 13225E9136-11		EA	3
		VALVE ASSY, GATE, 2 IN, ID (97403)13225E9111-Y		EA	3
	4720-01-138-8986	HOSE ASSY, DISCHARGE, QD, 2 IN. X 20 FT. (97403) 13225E9136-2		EA	3
	4730-01-068-5070	WYE FITTING, 2 IN., QD, FX F X M (81718) 319-K		EA	2
	4730-01-014-4925	REDUCER, QD, 2 IN., F X 1 1/2 IN. M		EA	3
	4730-01-064-0560	REDUCER, QD, 4 IN., F X 2 IN. M		EA	1
		TEE ASSY , QD, 4IN., FXMXM (97403) 13225E9117-Y1		EA	1
	4720-01-140-6288	HOSE ASSY, DISCHARGE, QD, 4 IN. X 20 FT. (97403) 13225E9136-4		EA	2
	4610-01-175-0758	HOSE AND NOZZLE CONNECTION KIT (97403) 13225E9130 CONSISTING OF THE FOLLOWING COMPONENTS:		EA	3

Section II. COMPONENTS OF END ITEM

(1) ILLUS NUMBER	(2) NATIONAL STOCK NUMBER	(3) DESCRIPTION CAGE and Part Number	Usable On Code	(4) U/M	(5) QTY
6		NOZZLE ASSY, QD, 1-INCH (97403) 13225E9130-Y		EA	1
		HOSE ASSY, DISCHARGE, QD, 1 IN. X 10 FT. (97403) 13225E9136-12		EA	3
		REGULATOR ASSY, QD (97403) 13225E9130-Y1		EA	1
		REDUCER, QD, 2 IN. X 1 N. (96906) MS9000-7		EA	1
	4936-01-106-8676	STAND ASSY, FUEL (97403)113225E9140		EA	1
	4320-01-120-7524	CONNECTION KIT, 125 GPM PUMP (97403) 13225E9113 CONSISTING OF THE FOLLOWING COMPONENTS:		EA	2
	4720-01-138-8986	HOSE ASSY, DISCHARGE, 2 IN. X 20 FT. (97403) 13225E9136-2		EA	2
	4730-01-186-0821	REDUCER, QD, 2 IN. X 4 IN. (96906) MS49000- 19		EA	1
		VALVE ASSY, GATE, 2 IN. (97403) 13225E9113-Y2		EA	2
		VALVE ASSY, CHECK, 2 IN. (97403) 13225E9113-Y3		EA	1
	4730-00-222-1844	NIPPLE, PIPE, 2 IN. (96906) MS51846-152		EA	1
	4730-00-649-9100	CAP, QD, 2 IN. (96906) MS27028- 11		EA	1
	4730-00-915-5127	PLUG, QD, 2 IN. (96906) MS27029-11		EA	1
4730-00-938-7997	COUPLING HALF, QD, MALE, 2 IN. (96906) MS27022-11		EA	1	
4730-00-079-1132	COUPLING HALF, QD, FEMALE, 2 IN. (96906) MS27020-11		EA	1	

Section II. COMPONENTS OF END ITEM

(1) ILLUS NUMBER	(2) NATIONAL STOCK NUMBER	(3) DESCRIPTION CAGE and Part Number	Usable On Code	(4) U/M	(5) QTY RQD	
7	4730-00-649-9103	COUPLING HALF, QD, FEMALE, 2 IN. (96906) MS27024-11		EA	1	
	472001-163-4684	HOSE ASSY, SUCTION, 2 IN. X 20 FT. (97403) 13225E9135-2		EA	2	
	4730-01-064-0560	REDUCER, QD, 4 IN. X 2 IN. (96906) MS49000- 17		EA	1	
	4320-01-120-7523	CONNECTION KIT, 350 GPM PUMP (97403) 13225E9112 CONSISTING OF THE FOLLOWING COMPONENTS:		EA	2	
	4720-01-163-5089		HOSE ASSY, SUCTION, 4 IN. X 20 FT. (97403) 13225E91354		EA	5
			TEE ASSY, 4 IN. (97403) 13225E9112-Y1		EA	1
			TEE ASSY, 4 IN. (97403) 13225E9112-Y2		EA	1
			VALVE ASSY, GATE, 4 IN. (97403) 13225E9112-Y		EA	2
	4720-01-140-6288		HOSE ASSY, DISCHARGE, 4 IN. X 20 FT. (97403) 13225E91364		EA	4
			TEE ASSY, 4 IN. (97403) 13225E9112-Y3		EA	1
METER ASSY, WATER, FLUID INDICATING, 4 IN. (97403) 13225E9117				EA	1	
TEE ASSY, 4 IN. (97403) 13225E9112-Y4				EA	1	
8	4610-01-120-7526	CONNECTION KIT, DUAL TANK (97403) 13225E9114 CONSISTING OF THE FOLLOWING COMPONENTS:		EA	8	
		4720-01-163-4682	HOSE ASSY, DISCHARGE, 4 IN. X 10 FT. (97403) 13225E9136-3		EA	2
		4720-01-140-6288	HOSE ASSY, DISCHARGE, 4 IN. X 20 FT. (97403) 13225E9136-4		EA	4
			TEE AND GATE VALVE ASSY, 4 IN. (97403) 13225E9114-Y2		EA	1

Section II. COMPONENTS OF END ITEM

(1) ILLUS NUMBER	(2) NATIONAL STOCK NUMBER	(3) DESCRIPTION CAGE and Part Number	Usable On Code	(4) U/M	(5) QTY RQD
9	4720-01-163-5089	HOSE ASSY, SUCTION, 4 IN. X 20 FT. (94703) 13225E9135-4		EA	3
	4720-01-163-4685	HOSE ASSY, SUCTION, 4 IN. X 10 FT. (94703) 13225E9135-3		EA	1
		TEE AND GATE VALVE ASSY, 4 IN. (94703) 13225E91 14-Y5		EA	1
		TEE AND GATE VALVE ASSY, 4 IN. (94703)13225E9114-Y6		EA	1
		TEE AND GATE VALVE ASSY, 4 IN. (94703)13225E9114-Y1		EA	1
	4610-01-123-7705	CONNECTION KIT, HOSE NOZZLE (97403)13225E9117 CONSISTING OF THE FOLLOWING COMPONENTS:		EA	4
		NOZZLE ASSY, DISTRIBUTION, 1- 1n IN. QD (97403) 13225E9117-Y		EA	1
	4720-01-174-8173	HOSE ASSY, DISCHARGE, 1-1/2 IN. X 25 FT. (97403) 13225E9136-11		EA	1
	4730-00-951-3295	REDUCER, QD, 2 IN. X i-1a IN. (96906) MS49000-5		EA	1
	4720-01-138-8986	HOSE ASSY, DISCHARGE, 2 IN. X 20 FT. (97403) 13225E9136-2		EA	1
	VALVE ASSY, 2 IN. QD (97403) 13225E9113-Y2		EA	1	
10	4730-01-064-0560	REDUCER, QD, 4 IN. X 2 IN. (96906) MS49000-17		EA	1
		TEE ASSY, QD, 4 IN. (97403) 13225E9117-Y1		EA	1
	4720-01-140-6288	HOSE ASSY, DISCHARGE (97403) 13225E9136-4		EA	2
	4936-01-106-8676	STAND ASSY, FUEL (97403) 13225E9140		EA	1
	4610-01-140-6776	CONNECTION KIT, HOSE, 2-INCH (97403)13225E9132 CONSISTING OF THE FOLLOWING COMPONENTS:		EA	6

Section II. COMPONENTS OF END ITEM

(1) ILLUS NUMBER	(2) NATIONAL STOCK NUMBER	(3) DESCRIPTION CAGE and Part Number	Usable On Code	(4) U/M	(5) QTY RQD
11	4720-01-138-8986	HOSE ASSY, DISCHARGE, 2 IN. X 20 FT. (97403)13225E9136-2		EA	1
		VALVE ASSY, 2 IN. (97403) 13225E9113-Y2		EA	1
	4730-01-064-0560	REDUCER, QD, 4 IN. X 2 IN. (96906) MS9000-17		EA	1
		TEE ASSY, 4 IN. (97403) 13225E9117-Y1		EA	1
	4720-01-140-6288	HOSE ASSY, DISCHARGE, 4 IN. X 20 FT. (97403) 13225E9136-4		EA	2
	4936-01-106-8676	STAND ASSY, FUEL (97403)13225E9140		EA	1
	4610-01-140-6775	CONNECTION KIT, HOSE, 4-INCH (97403)13225E9133 CONSISTING OF THE FOLLOWING COMPONENTS:		EA	2
		BUTTERFLY VALVE ASSY, QD, 4 IN. (97403)13225E9133-Y2		EA	1
	4720-01-140-6288	HOSE ASSY, DISCHARGE, 4 IN. X 20 FT. (97403) 13225E9136-4		EA	3
		VALVE ASSY, BALL, 4 IN. (97403)13225E9133-Y	FFR	EA	1
	4730-00-840-5346	TEE ASSY, 4 IN. (97403)13225E9117-1	FFR	EA	1
		TEE AND GATE VALVE ASSY, 4 IN. (97403)13225E9133-Y1	FKG	EA	1
	4720-01-163-5089	HOSE ASSY, SUCTION. 4 IN. X 20 FT. (97403) 13225E9135-4	FKG	EA	1
	4930-00-106-8676	STAND ASSY, FUEL (97403)13225E9140		EA	1
12	5411-01-132-1269	SHELTER, EQUIPMENT, MULTIPURPOSE (TRICON) (81349) MIL-S-28633		EA	12
13	4610-01-250-3724	HYPOCHLORINATION UNIT W/BYPASS (81349) MIL-H-12732		EA	2

Section II. COMPONENTS OF END ITEM

(1) ILLUS NUMBER	(2) NATIONAL STOCK NUMBER	(3) DESCRIPTION CAGE and Part Number	(4) Usable On Code U/M	(5) QTY RQD
14	4610-01-120-7522	INTERCONNECTION KIT, 4-INCH (97403)13225E9115 CONSISTING OF THE FOLLOWING COMPONENTS: TEE ASSY, 4 IN. (94703)13225E9115-Y 4270-01-140-6288 HOSE ASSY, DISCHARGE (97403) 13225E9136-4 TEE ASSY, 4 IN. (97403) 13225E9115-Y1	EA	2
15	4320-01-156-3873	PUMP, 125 GPM AT 50' TDH (81349) MIL-P-52109	EA	2
16	4320-01-158-2954	PUMP, 350 GPM AT 275' TDH (97403) MIL-P-52144	EA	3
17	7240-00-177-6154	SPOUT, CAN, FLEXIBLE (81349) MIL-S-1285	EA	8
18	5430-01-106-9677	TANK, FABRIC COLLAPSIBLE (81349) MIL-T-53029	EA	16

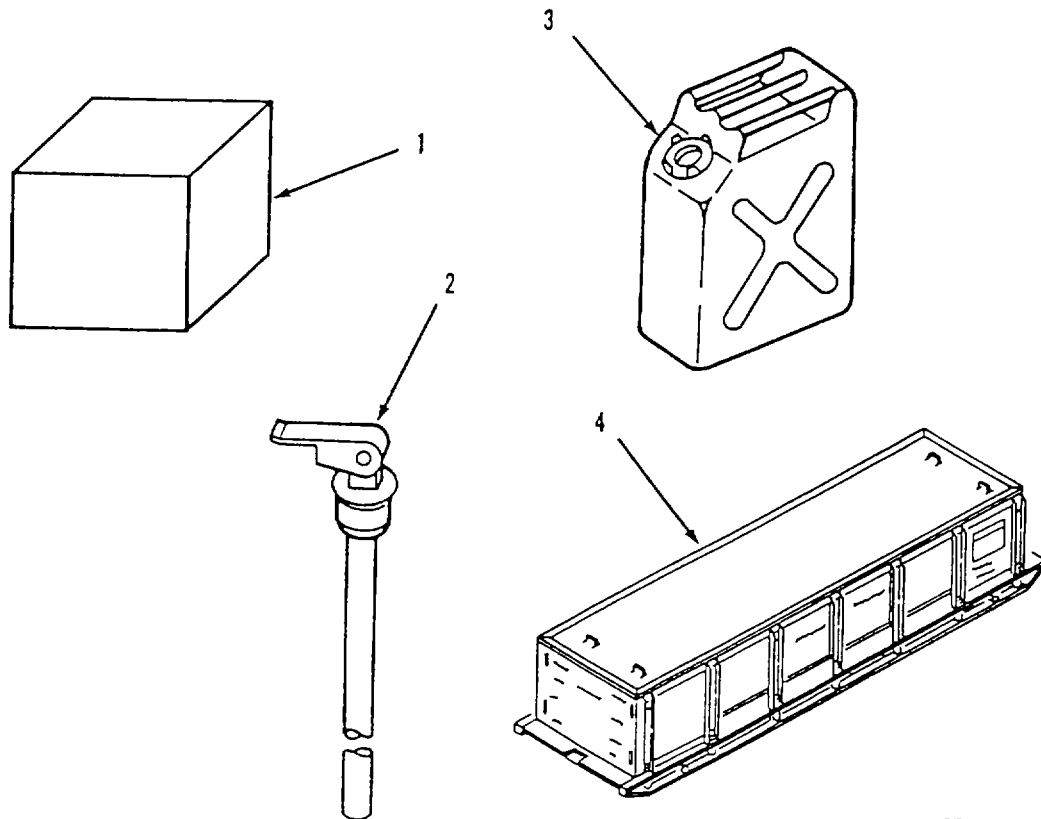

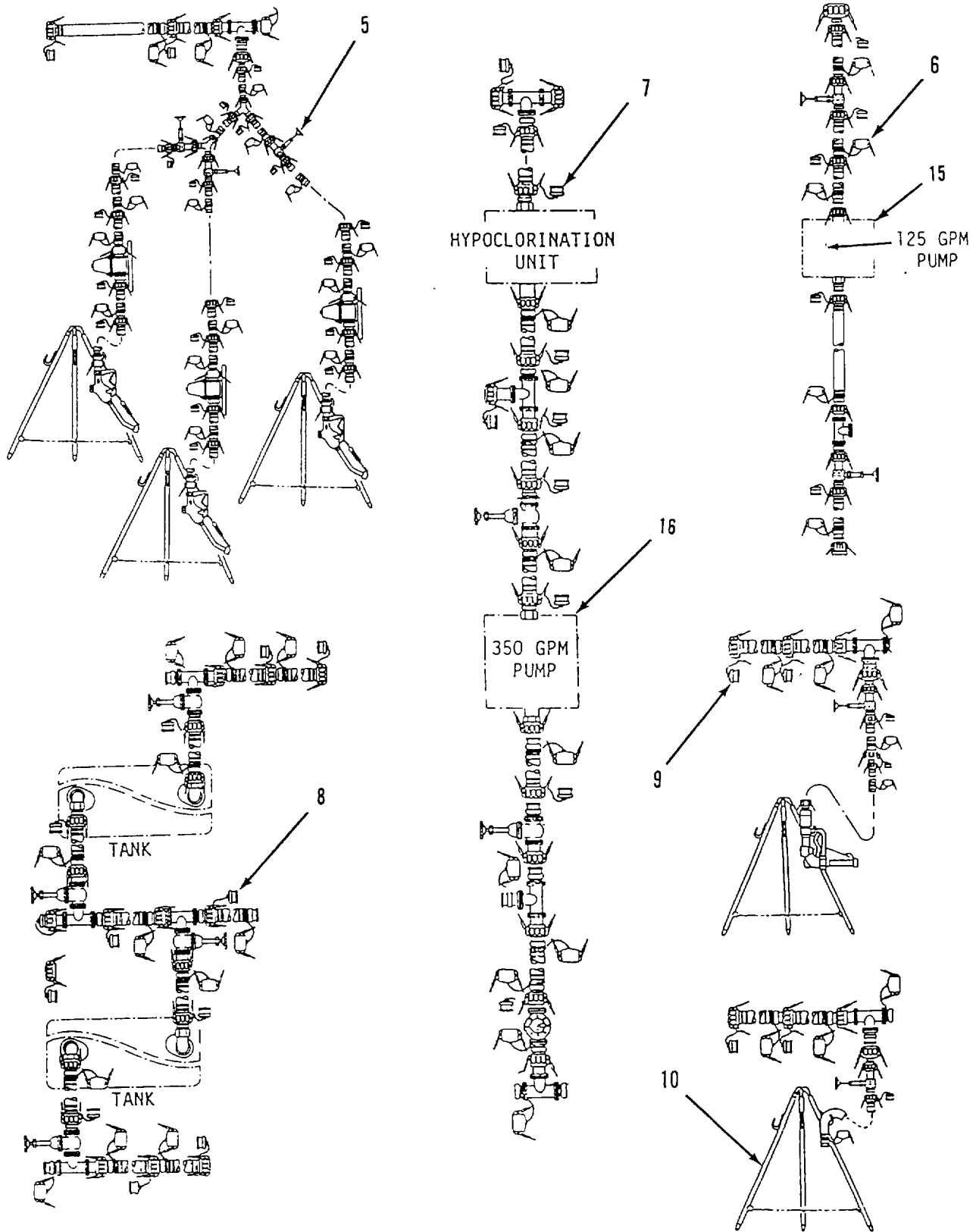

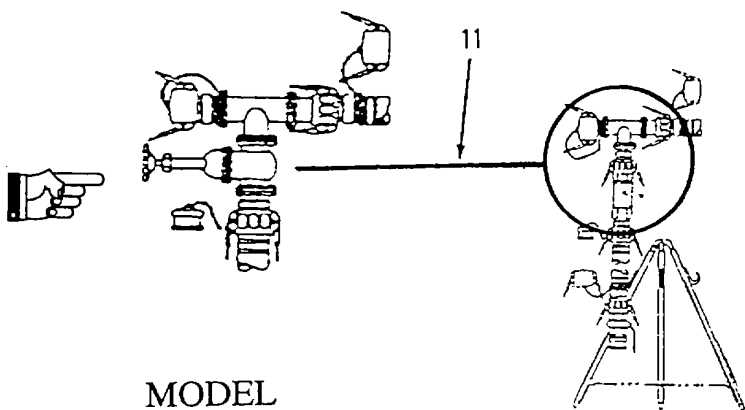

MODEL
800KWSDS

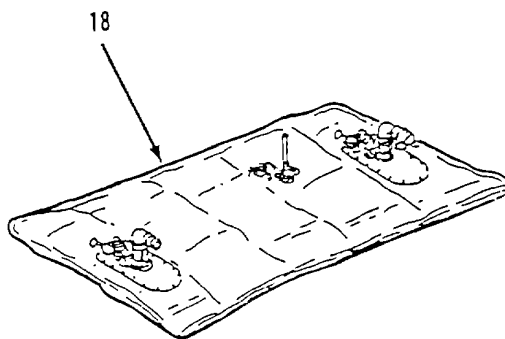
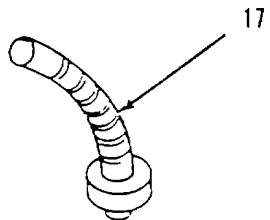
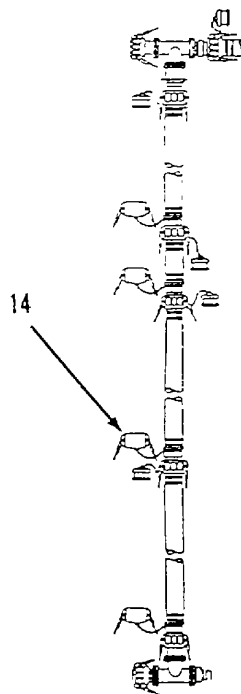
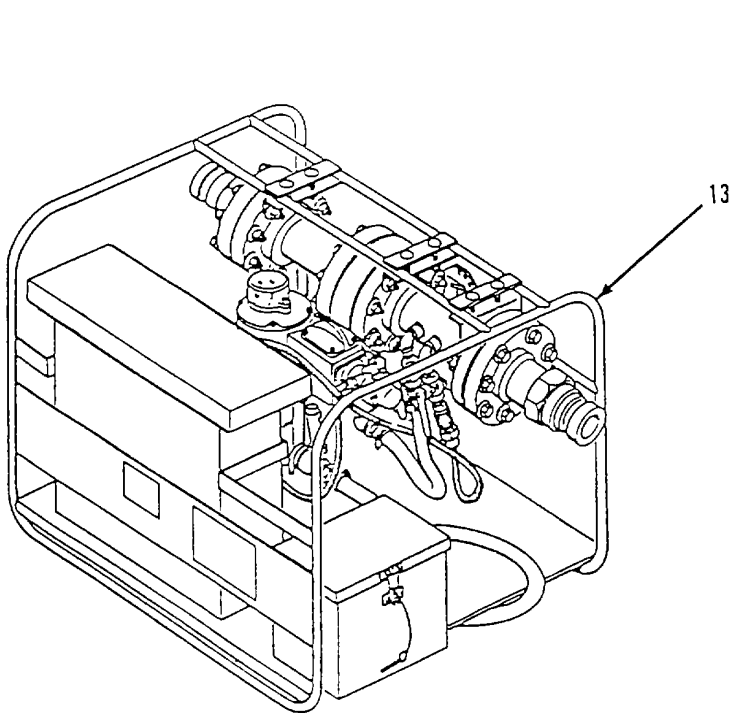
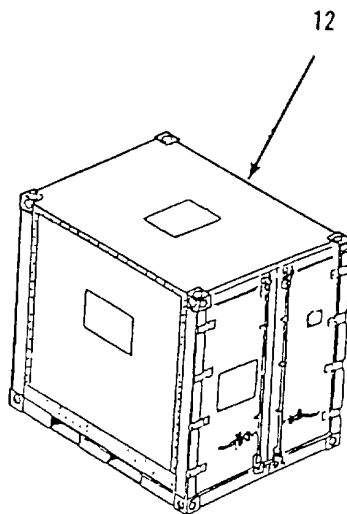

Section III. BASIC ISSUE ITEMS

(1) ILLUS NUMBER	(2) NATIONAL STOCK NUMBER	(3) DESCRIPTION CAGE and Part Number	Usable On Code	(4) U/M	(5) QTY RQD
1		TECHNICAL MANUAL, OPERATOR'S UNIT AND DIRECT SUPPORT MAINTENANCE MANUAL FOR 800K WATER STORAGE AND DISTRIBUTION SYSTEM, TM10-4610-243-13.		EA	1

TM 10-4610-243-13

TECHNICAL MANUAL
OPERATOR'S, UNIT AND
DIRECT SUPPORT
MAINTENANCE MANUAL
800K WATER STORAGE AND
DISTRIBUTION SYSTEM
MODEL WSDS810
NSN: 4610-01-360-1581

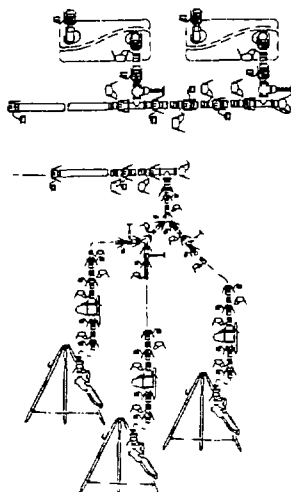

HOW TO USE THIS MANUAL	iii
EQUIPMENT DESCRIPTION AND DATA	1-3
OPERATION UNDER USUAL CONDITIONS	2-27
OPERATOR TROUBLESHOOTING PROCEDURES	3-1
UNIT MAINTENANCE PROCEDURES	4-1
DIRECT SUPPORT MAINTENANCE PROCEDURES	5-1
MAINTENANCE ALLOCATION CHART	B-1
COMPONENTS OF END ITEM AND BASIC ISSUE ITEMS LIST	C-1
EXPENDABLE/DURABLE SUPPLIES AND MATERIALS LIST	E-1
ALPHABETICAL INDEX	Index-1

DISTRIBUTION STATEMENT A Approved for public release, distribution is unlimited

HEADQUARTERS, DEPARTMENT OF THE ARMY
4 DECEMBER 1992

APPENDIX D
ADDITIONAL AUTHORIZATION LIST

NOT APPLICABLE

APPENDIX E

EXPENDABLE/DURABLE SUPPLIES AND MATERIALS LIST

Section I. INTRODUCTION

D-1. SCOPE.

This appendix lists expendable/durable supplies and materials you will need to operate and maintain the 800K Water Storage and Distribution System. This listing is for informational purpose only and is not authority to requisition the listed items. These items are authorized to you by CTA 50-970, Expendable/Durable Items (Except Medical, Class V, Repair Parts, and Heraldic Items), or CTA 8-100, Army Medical Department Expendable/Durable Items.

D-2. EXPLANATION OF COLUMNS.

a. Column 1 - Item Number. This number is assigned to the entry in the listing and is referenced in the task Initial Setup instructions to identify the material, e g., "Dry-cleaning solvent (App E)."

b. Column 2 - Category. This column identified the lowest category of maintenance that requires the listed item:

- C - Operator/Crew
- 0 - Unit Maintenance
- F - Direct Support Maintenance
- G - General Support Maintenance

c. Column 3 - National Stock Number. This is the national stock number assigned to the item; use it to request or requisition the items.

d. Column 4 - Description. Indicates the federal item name and, if required, a description to identify the item. The last line for each item indicates the part number followed by the Commercial And Government Entity (CAGE) Code for Manufacturer in parentheses, if applicable.

e. Column 5 - Unit of Measure (U/M). Indicates the measure used in performing the actual maintenance function. This measure is expressed by a two character alphabetical abbreviation (e.g. ea., in, pr). If the unit of measure differs from the rest of the issue, requisition the lowest unit of issue that will satisfy your requirements.

Section II. EXPENDABLE/DURABLE SUPPLIES AND MATERIALS LIST

Item Number	Category	National Stock Number	Description	U/M
1	0	7930-00-985-6911	Detergent, General Purpose (81349) MIL-D-16791	GL
2	0	7920-00-205-1711	Rags, wiping (58536) A A-531	LB
3	0	8030-00-889-3535	Tape, Anti-Seize (80244) MIL-T-27730 SZ2	RL
4	0	8030-00-251-5048	Corrosion Preventive Compound 81349) MIL-C-10382	GL

APPENDIX F
LUBRICATION INSTRUCTIONS

NOT APPLICABLE











APPENDIX G

ILLUSTRATED LIST OF MANUFACTURED ITEMS

NOT APPLICABLE

APPENDIX H











TORQUE LIMITS

FASTENER	TYPE	MIN TENSILE STRENGTH	MATERIAL	BODY SIZE OR OUTSIDE DIAMETER OF FASTENER													
				7/8	1	1 1/8	1 1/4	1 3/8	1 1/2	1 5/8	1 3/4	1 7/8	2	2 1/4	2 1/2	2 3/4	3
	SAE 0-1-2	74,000 PSI	LOW CARBON STEEL	206	310	480	675	900	1100	1470	1900	2360	2750	3450	4400	7350	9500
	SAE 3	100,000 PSI	MEDIUM CARBON STEEL	372	551	872	1211	1624	1943	2660	3463	4695	5427	7226	8049	13450	17548
	SAE 5	120,000 PSI	MEDIUM CARBON HEAT TREAT STEEL	382	587	794	1105	1500	1775	2425	3150	4200	4550	6550	7175	13000	16000
	SAE 6	133,000 PSI	MEDIUM CARBON STEEL QUENCHED TEMPERED	550	825	1304	1815	2434	2913	3985	5189	6980	7491	10825	14983	20151	26286
	SAE 7	133,000 PSI	MEDIUM CARBON ALLOY STEEL	570	840	1325	1825	2500	3000	4000	5300	7000	7500	11000	15500	21000	27000
	SAE 8	150,000 PSI	MEDIUM CARBON ALLOY STEEL	600	900	1430	1975	2650	3200	4400	5650	7600	8200	12000	17000	23000	29000
	SOCKET HEAD CAP SCREW	160,000 PSI	HIGH CARBON CASE HARDENED STEEL	640	970	1520	2130	2850	3450	4700	6100	8200	8800	13000	18000	24000	31000
	SOCKET SET SCREW	212,000 PSI	HIGH CARBON CASE HARDENED STEEL														
	MACHINE SCREW YELLOW BRASS	60,000 PSI	COPPER (CU) 63% ZINC (ZU) 37%	160	215	325	400		595								
	SILICONE BRONZE TYPE "B"	70,000 PSI	COPPER (CU) 96% ZINC (ZN) 2% SILICON (SI) 2%	180	250	365	450		655								

There is no difference in the above chart between the torque figures for fine or coarse threads. The torque figures for a finely-threaded fastener as compared to a coarsely-threaded fastener of the same diameter may be slightly higher but hardly worth mentioning.

APPENDIX H

TORQUE LIMITS - cont.

FASTENER	TYPE	MIN TENSILE STRENGTH	MATERIAL	BODY SIZE OR OUTSIDE DIAMETER OF FASTENER															
				2	3	4	5	6	8	10	1/4	1/10	1/8	1/16	1/2	5/16	3/8	3/4	
	SAE 0-1-2	74 000 PSI	LOW CARBON STEEL									6	12	20	32	47	69	96	155
	SAE 3	100,000 PSI	MEDIUM CARBON STEEL									9	17	30	47	69	103	145	234
	SAE 5	120 000 PSI	MEDIUM CARBON HEAT TREAT STEEL									10	19	33	54	78	114	154	257
	SAE 6	133,000 PSI	MEDIUM CARBON STEEL QUENCHED TEMPERED									12.5	24	43	69	106	150	209	350
	SAE 7	133 000 PSI	MEDIUM CARBON ALLOY STEEL									13	25	44	71	110	154	215	360
	SAE 8	150,000 PSI	MEDIUM CARBON ALLOY STEEL									14	29	47	78	119	169	230	380
	SOCKET HEAD CAP SCREW	160,000 PSI	HIGH CARBON CASE HARDENED STEEL	TORQUE VALUES All figures are foot-pounds except those marked with an asterisk (*), which are inch-pounds															
	SOCKET SET SCREW	212,000 PSI	HIGH CARBON CASE HARDENED STEEL					9*	16*	30*	70*	140*	18	29	43	63	100	146	
	MACHINE SCREW YELLOW BRASS	60,000 PSI	COPPER (CU) 63% ZINC (ZU) 37%	2*	3.3*	4.4*	6.4*	8*	16*	20*	65*	110*	17	27	37	49	78	104	
	SILICONE BRONZE TYPE "B"	70 000 PSI	COPPER (CU) 96% ZINC (ZN) 2% SILICON (SI) 2%	2.3*	3.7*	4.9*	7.2*	10*	19*	22*	70*	125*	20	30	41	53	88	117	

There is no difference in the above chart between the torque figures for fine or coarse threads. The torque figures for a finely-threaded fastener as compared to a coarsely-threaded fastener of the same diameter may be slightly higher but hardly worth mentioning.

APPENDIX I

MANDATORY REPLACEMENT PARTS

ITEM NO.	NOMENCLATURE	PART NUMBER
1	Gasket (1-inch)	MS27030-3
2	Gasket (1 1/2 inch)	MS27030-5
3	Gasket (2-inch)	MS27030-6
4	Gasket (4-inch)	MS27030-9
5	Seat	C254
6	Strapping	C204
7	Seal	C256
8	Strapping	C206
9	Packing	BV1182-8
10	Gasket, Flange (4-inch)	13220E1069-1
11	Lockwasher	MS35338-46
12	Gasket	MS27030-1
13	Packing Ring	231AW-0219 2P
14	Disc	300ALM0408 2D
15	Diaphragm	1781
16	Gasket	MS27030-2
17	Cotter Pin	MS24665-134
18	Packing	231AW-0219 2P
19	Disc	231A--0909 2D
20	Disc	231A--0913 2D
21	Seal	6596-N
22	Seal	66150-N
23	O-ring	6596-B
24	Bearing, Top	7410N
25	Bearing, Bottom	7411N
26	Sleeve	EPDM
27	Cotter pin	7959D
28	Packing Ring	235RF-05082P

APPENDIX I

MANDATORY REPLACEMENT PARTS - cont.

ITEM NO.	NOMENCLATURE	PART NUMBER
29	Gasket, Flange (gate valve)	235RF-05092G
30	Lockwasher	235RF-02212W
31	Gasket (roll for top cover)	22036-9
32	Gasket (end panel)	22036-8
33	Gasket (side panel)	22002-17
34	Packing	AP-39-9
35	Gasket, Body	SP-20-13
36	Seat	SP-20-8B
37	Lockwasher	AXXMXL
38	Locking Nut	LXXOXL
39	Packing	41NT300C-13/P-6
40	Self Locking Nut	MS51922-54
41	Gasket, Flange (water meter)	ASME-B16.21
42	Gasket (water meter)	8341-304

ALPHABETICAL INDEX

Paragraph	Page
125 GPM Pump Connection Kit Maintenance.....	4-92.3
2-Inch Hose Connection Kit Maintenance.....	4-58
350 Gpm Pump Connection Kit.....	4-68.4
4-Inch Hose Connection Kit Maintenance.....	4-58
- A -	
Administrative Storage.....	4-130
Assembly and Preparation for Use.....	2-27
- B -	
Bag Filler Connection Kit Maintenance.....	4-27
Butterfly Valve Assembly Repair.....	4-58
Butterfly Valves (Description and Use).....	2-6
- C -	
Check Valve (2-Inch) Repair.....	4-93
Checking Unpacked Equipment.....	4-3
Common Tools and Equipment.....	4-2
Component Replacement.....	3-26
Corrosion Prevention and Control (CPC).....	1-2
- D -	
Decals and Instruction Plates.....	2-66
Destruction of Army Materiel to Prevent Enemy Use.....	1-2
Discharge and Suction Hose Repair.....	4-28
Distribution Nozzle (1 1/2-Inch) Repair.....	4-53
Distribution Nozzle (1-Inch) Repair.....	4-40
Distribution Nozzle (Description and Use).....	2-3
Dual Tank Connection Kit Maintenance.....	4-96
- E -	
Emergency Procedures.....	2-96
Equipment Characteristics, Capabilities and Features.....	1-3
Equipment Data.....	1-8
- F -	

ALPHABETICAL INDEX

Paragraph	Page
- G -	
Gate Valve (4-Inch) Assembly Repair	4-84
Gate Valve Assembly (2-Inch) Repair	4-33
Gate Valves (Description and Use).....	2-2
General.....	2-7, 4-27
General Cleaning and Decontamination.....	2-97
Glossary.....	1-2
- H -	
Hose Nozzle Kit Maintenance	4-53
- I -	
Initial Adjustment	2-62
Interconnection Kit Maintenance	4-112
Introduction	3-1
Introduction	4-6
Introduction	5-1
- J -	
- K -	
- L -	
Leakage Definitions for Operator PMCS.....	2-8
List of Abbreviations.....	1-2
Location and Description of Major Components.....	1-4
- M -	
Maintenance Forms, Records and Reports	1-1
Malfunction Index (Operator).....	3-2
Malfunction Index (Unit)	4-7
- N -	
Nomenclature Cross Reference List.....	1-2
Nozzle Stand Assembly Repair	4-51
- O -	
Operating Auxiliary Equipment	2-68
Operating Procedures	2-62
Operation in Dusty or Sandy Areas	2-95
Operation in Extreme Cold (Below 32° F).....	2-93

ALPHABETICAL INDEX

Paragraph	Page
Operation in Extreme Heat.....	2-94
Operation in Salt Water Areas.....	2-95
Operator Preventive Maintenance Checks and Services.....	2-10
- P -	
Personal Safety.....	4-27
PMCS Procedures (Operator).....	2-7
Preparation for Movement.....	2-68
Proper Equipment.....	4-27
- Q -	
Quick Acting Valve Assembly Repair.....	4-63
Quick Acting Valves (Description and Use).....	2-5
Quick Disconnect Coupling Repair.....	3-28
- R -	
Repair Parts.....	4-2
Reporting of Equipment Improvement Recommendations (EIR).....	1-2
- S -	
Scope.....	1-1
Security Procedures.....	4-130
Shelter Requirements.....	4-3
Siting.....	4-2
Special Tools, TMDE and Support Equipment.....	4-2
System Technical Principles of Operation.....	1-10
- T -	
Tee and Gate Valve Assembly (9114-Y1) Repair.....	4-96
Tee and Gate Valve Assembly (9114-Y2) Repair.....	4-100
Tee and Gate Valve Assembly (9114-Y5) Repair.....	4-108
Tee and Gate Valve Assembly (9114-Y6) Repair.....	4-108
Tee and Gate Valve Assembly (9133-Y1) Repair.....	4-68
Tee Assembly (9112-Y1) Repair.....	4-68.4
Tee Assembly (9112-Y2) Repair.....	4-72
Tee Assembly (9112-Y3) Repair.....	4-76
Tee Assembly (9112-Y4) Repair.....	4-80
Tee Assembly (9115-Y) Repair.....	4-112
Tee Assembly (9115-Y1) Repair.....	4-116
Tee Assembly (9117-Y1) Repair.....	4-36
Troubleshooting (Unit).....	4-6
Troubleshooting Table (Operator).....	3-2

ALPHABETICAL INDEX

Paragraph	Page
	-U-
	-V-
	- W -
Water Meter Assembly Repair.....	4-89
Water Meter Assembly Repair (Model 800KWSDS)	4-92
Water Meters (Description and Use).....	2-4
Water Pressure Regulator Repair.....	4-44
Water Tank Chest Repair.....	4-120
Water Tank Chest Repair.....	5-1
	-X-
	-Y-
	-Z-

*U.S. GOVERNMENT PRINTING OFFICE: 1994-555-121/80064

By Order of the Secretary of the Army:

Official:

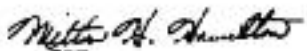

MILTON H. HAMILTON
*Administrative Assistant to the
Secretary of the Army*
03355

GORDON R. SULLIVAN
*General, United States Army
Chief of Staff*

DISTRIBUTION:

To be distributed in accordance with DA Form 12-25-E, block no. 6018, requirements for TM 10-4610-243-13.

These are the instructions for sending an electronic 2028

The following format must be used if submitting an electronic 2028. The subject line must be exactly the same and all fields must be included; however, only the following fields are mandatory: 1, 3, 4, 5, 6, 7, 8, 9, 10, 13, 15, 16, 17 and 27.

From: "Whomever" whomever@avma27.army.mil
To: rock-tacom-tech-pubs@conus.army.mil

Subject DA Form 2028

1. **From:** Joe Smith
2. **Unit:** home
3. **Address:** 4300 Park
4. **City:** Hometown
5. **St:** MO
6. **Zip:** 77777
7. **Date Sent:** 19-OCT-93
8. **Pub no:** 55-1915-200-10
9. **Pub Title:** TM
10. **Publication Date:** 11-APR-88
11. **Change Number:** 12
12. **Submitter Rank:** MSG
13. **Submitter Fname:** Joe
14. **Submitter Mname:** T
15. **Submitter Lname:** Smith
16. **Submitter Phone:** 123-123-1234
17. **Problem:** 1
18. **Page:** 1
19. **Paragraph:** 3
20. **Line:** 4
21. **NSN:** 5
22. **Reference:** 6
23. **Figure:** 7
24. **Table:** 8
25. **Item:** 9
26. **Total:** 123
27. **Text:**

This is the text for the problem below line 27.

RECOMMENDED CHANGES TO PUBLICATIONS AND BLANK FORMS For use of this form, see AR 25-30; the proponent agency is ODISC4.						Use Part II (<i>reverse</i>) for Repair Parts and Special Tool Lists (RPSTL) and Supply Catalogs/Supply Manuals (SC/SM).	DATE
TO: (<i>Forward to proponent of publication or form</i>) (<i>Include ZIP Code</i>) AMSTA-LC-LPIT / TECH PUBS, TACOM-RI 1 Rock Island Arsenal Rock Island, IL 61299-7630						FROM: (<i>Activity and location</i>) (<i>Include ZIP Code</i>)	
PART I - ALL PUBLICATIONS (EXCEPT RPSTL AND SC/SM) AND BLANK FORMS							
PUBLICATION/FORM NUMBER TM 10-4610-243-13						DATE 4 December 1992	TITLE 800K Water Storage and Distribution System, Models WSDS810 and 800KWSDS
ITEM NO.	PAGE NO.	PARA-GRAPH	LINE NO. *	FIGURE NO.	TABLE NO.	RECOMMENDED CHANGES AND REASON (<i>Provide exact wording of recommended changes, if possible.</i>)	
<i>*Reference to line numbers within the paragraph or subparagraph.</i>							
TYPED NAME, GRADE OR TITLE				TELEPHONE EXCHANGE/AUTOVON, PLUS EXTENSION		SIGNATURE	

TO: <i>(Forward direct to addressee listed in publication)</i> AMSTA-LC-LPIT / TECH PUBS, TACOM-RI 1 Rock Island Arsenal Rock Island, IL 61299-7630	FROM: <i>(Activity and location) (Include ZIP Code)</i>	DATE
--	---	------

PART II – REPAIR PARTS AND SPECIAL TOOL LISTS AND SUPPLY CATALOGS/SUPPLY MANUALS

PUBLICATION NUMBER TM 10-4610-243-13	DATE 4 December 1992	TITLE 800K Water Storage and Distribution System, Models WSDS810 and 800KWSDS
---	-------------------------	---

PAGE NO.	COLM NO.	LINE NO.	NATIONAL STOCK NUMBER	REFERENCE NO.	FIGURE NO.	ITEM NO.	TOTAL NO. OF MAJOR ITEMS SUPPORTED	RECOMMENDED ACTION

PART III – REMARKS *(Any general remarks or recommendations, or suggestions for improvement of publications and blank forms. Additional blank sheets may be used if more space is needed.)*

TYPED NAME, GRADE OR TITLE	TELEPHONE EXCHANGE/AUTOVON, PLUS EXTENSION	SIGNATURE
----------------------------	--	-----------

RECOMMENDED CHANGES TO PUBLICATIONS AND BLANK FORMS						Use Part II (<i>reverse</i>) for Repair Parts and Special Tool Lists (RPSTL) and Supply Catalogs/Supply Manuals (SC/SM).	DATE
For use of this form, see AR 25-30; the proponent agency is ODISC4.							
TO: (<i>Forward to proponent of publication or form</i>) (<i>Include ZIP Code</i>) AMSTA-LC-LPIT / TECH PUBS, TACOM-RI 1 Rock Island Arsenal Rock Island, IL 61299-7630						FROM: (<i>Activity and location</i>) (<i>Include ZIP Code</i>)	
PART I - ALL PUBLICATIONS (EXCEPT RPSTL AND SC/SM) AND BLANK FORMS							
PUBLICATION/FORM NUMBER TM 10-4610-243-13						DATE 4 December 1992	TITLE 800K Water Storage and Distribution System, Models WSDS810 and 800KWSDS
ITEM NO.	PAGE NO.	PARA-GRAPH	LINE NO. *	FIGURE NO.	TABLE NO.	RECOMMENDED CHANGES AND REASON (<i>Provide exact wording of recommended changes, if possible.</i>)	
<i>*Reference to line numbers within the paragraph or subparagraph.</i>							
TYPED NAME, GRADE OR TITLE				TELEPHONE EXCHANGE/AUTOVON, PLUS EXTENSION		SIGNATURE	

TO: <i>(Forward direct to addressee listed in publication)</i> AMSTA-LC-LPIT / TECH PUBS, TACOM-RI 1 Rock Island Arsenal Rock Island, IL 61299-7630	FROM: <i>(Activity and location) (Include ZIP Code)</i>	DATE
--	---	------

PART II - REPAIR PARTS AND SPECIAL TOOL LISTS AND SUPPLY CATALOGS/SUPPLY MANUALS

PUBLICATION NUMBER TM 10-4610-243-13	DATE 4 December 1992	TITLE 800K Water Storage and Distribution System, Models WSDS810 and 800KWSDS
---	-------------------------	---

PAGE NO.	COLM NO.	LINE NO.	NATIONAL STOCK NUMBER	REFERENCE NO.	FIGURE NO.	ITEM NO.	TOTAL NO. OF MAJOR ITEMS SUPPORTED	RECOMMENDED ACTION

PART III - REMARKS *(Any general remarks or recommendations, or suggestions for improvement of publications and blank forms. Additional blank sheets may be used if more space is needed.)*

TYPED NAME, GRADE OR TITLE	TELEPHONE EXCHANGE/AUTOVON, PLUS EXTENSION	SIGNATURE
----------------------------	--	-----------

RECOMMENDED CHANGES TO PUBLICATIONS AND BLANK FORMS For use of this form, see AR 25-30; the proponent agency is ODISC4.						Use Part II (<i>reverse</i>) for Repair Parts and Special Tool Lists (RPSTL) and Supply Catalogs/Supply Manuals (SC/SM).	DATE
TO: (<i>Forward to proponent of publication or form</i>) (<i>Include ZIP Code</i>) AMSTA-LC-LPIT / TECH PUBS, TACOM-RI 1 Rock Island Arsenal Rock Island, IL 61299-7630						FROM: (<i>Activity and location</i>) (<i>Include ZIP Code</i>)	
PART I - ALL PUBLICATIONS (EXCEPT RPSTL AND SC/SM) AND BLANK FORMS							
PUBLICATION/FORM NUMBER TM 10-4610-243-13						DATE 4 December 1992	TITLE 800K Water Storage and Distribution System, Models WSDS810 and 800KWSDS
ITEM NO.	PAGE NO.	PARA-GRAPH	LINE NO. *	FIGURE NO.	TABLE NO.	RECOMMENDED CHANGES AND REASON (<i>Provide exact wording of recommended changes, if possible.</i>)	
<i>*Reference to line numbers within the paragraph or subparagraph.</i>							
TYPED NAME, GRADE OR TITLE				TELEPHONE EXCHANGE/AUTOVON, PLUS EXTENSION		SIGNATURE	

TO: <i>(Forward direct to addressee listed in publication)</i> AMSTA-LC-LPIT / TECH PUBS, TACOM-RI 1 Rock Island Arsenal Rock Island, IL 61299-7630	FROM: <i>(Activity and location) (Include ZIP Code)</i>	DATE
--	---	------

PART II - REPAIR PARTS AND SPECIAL TOOL LISTS AND SUPPLY CATALOGS/SUPPLY MANUALS

PUBLICATION NUMBER TM 10-4610-243-13	DATE 4 December 1992	TITLE 800K Water Storage and Distribution System, Models WSDS810 and 800KWSDS
---	-------------------------	---

PAGE NO.	COLM NO.	LINE NO.	NATIONAL STOCK NUMBER	REFERENCE NO.	FIGURE NO.	ITEM NO.	TOTAL NO. OF MAJOR ITEMS SUPPORTED	RECOMMENDED ACTION

PART III - REMARKS *(Any general remarks or recommendations, or suggestions for improvement of publications and blank forms. Additional blank sheets may be used if more space is needed.)*

TYPED NAME, GRADE OR TITLE	TELEPHONE EXCHANGE/AUTOVON, PLUS EXTENSION	SIGNATURE
----------------------------	--	-----------

The Metric System and Equivalents

Linear Measure

1 centimeter = 10 millimeters = .39 inch
 1 decimeter = 10 centimeters = 3.94 inches
 1 meter = 10 decimeters = 39.37 inches
 1 dekameter = 10 meters = 32.8 feet
 1 hectometer = 10 dekameters = 328.08 feet
 1 kilometer = 10 hectometers = 3,280.8 feet

Weights

1 centigram = 10 milligrams = .15 grain
 1 decigram = 10 centigrams = 1.54 grains
 1 gram = 10 decigrams = .035 ounce
 1 dekagram = 10 grams = .35 ounce
 1 hectogram = 10 dekagrams = 3.52 ounces
 1 kilogram = 10 hectograms = 2.2 pounds
 1 quintal = 100 kilograms = 220.46 pounds
 1 metric ton = 10 quintals = 1.1 short tons

Liquid Measure

1 centiliter = 10 milliliters = .34 fl. ounce
 1 deciliter = 10 centiliters = 3.38 fl. ounces
 1 liter = 10 deciliters = 33.81 fl. ounces
 1 dekaliter = 10 liters = 2.64 gallons
 1 hectoliter = 10 dekaliters = 26.42 gallons
 1 kiloliter = 10 hectoliters = 264.18 gallons

Square Measure

1 sq. centimeter = 100 sq. millimeters = .155 sq. inch
 1 sq. decimeter = 100 sq. centimeters = 15.5 sq. inches
 1 sq. meter (centare) = 100 sq. decimeters = 10.76 sq. feet
 1 sq. dekameter (are) = 100 sq. meters = 1,076.4 sq. feet
 1 sq. hectometer (hectare) = 100 sq. dekameters = 2.47 acres
 1 sq. kilometer = 100 sq. hectometers = .386 sq. mile

Cubic Measure

1 cu. centimeter = 1000 cu. millimeters = .06 cu. inch
 1 cu. decimeter = 1000 cu. centimeters = 61.02 cu. inches
 1 cu. meter = 1000 cu. decimeters = 35.31 feet

Approximate Conversion Factors

<i>To change</i>	<i>To</i>	<i>Multiply by</i>	<i>To change</i>	<i>To</i>	<i>Multiply by</i>
inches	centimeters	2.540	ounce-inches	newton-meters	.007062
feet	meters	.305	centimeters	inches	.394
yards	meters	.914	meters	feet	3.280
miles	kilometers	1.609	meters	yards	1.094
square inches	square centimeters	6.451	kilometers	miles	.621
square feet	square meters	.093	square centimeters	square inches	.155
square yards	square meters	.836	square meters	square feet	10.764
square miles	square kilometers	2.590	square meters	square yards	1.196
acres	square hectometers	.405	square kilometers	square miles	.386
cubic feet	cubic meters	.028	square hectometers	acres	2.471
cubic yards	cubic meters	.765	cubic meters	cubic feet	35.315
fluid ounces	milliliters	29.573	cubic meters	cubic yards	1.308
pints	liters	.473	milliliters	fluid ounces	.034
quarts	liters	.946	liters	pints	2.113
gallons	liters	3.785	liters	quarts	1.057
ounces	grams	28.349	liters	gallons	.264
pounds	kilograms	.454	grams	ounces	.035
short tons	metric tons	.907	metric tons	short tons	1.102
pound-feet	newton-meters	1.356	kilograms	pounds	2.205
pound-inches	newton-meters	.11296			

Temperature (Exact)

°F Fahrenheit temperature

5/9 (after subtracting 32)

°C Celsius temperature

